

KENYA ELECTRICITY GRID CODE

Contact details:

Energy Regulatory Commission

Integrity Centre, 1st Floor, Valley/Milimani Road

P O Box 42681, 00100 GPO Nairobi, Kenya

Phone: +254 (20) 2847 000/200/242 or 2717616/31 Fax +254 (20) 2717603/21

Cell phones: +254 (0) 722 947 or 734 414333

Email: info@erb.go.ke

Website: [www. erb.go.ke](http://www.erb.go.ke)

March 2008 Edition

Energy Regulatory Commission

P O Box 42681, 00100 GPO Nairobi, Kenya

TABLE OF CONTENTS

| | Page |
|--|------|
| PREAMBLE..... | 3 |
| CHAPTER 1 INTRODUCTION, CODE OBJECTIVES AND PARTICIPANTS | 4 |
| CHAPTER 2 ACRONYMS AND GLOSSARY | 10 |
| CHAPTER 3 NETWORK CONNECTION..... | 35 |
| SCHEDULES TO CHAPTER 3 | 65 |
| CHAPTER 4 METERING AND RETAIL SUPPLY OF ELECTRICITY..... | 105 |
| SCHEDULES TO CHAPTER 4 | 123 |
| CHAPTER 5 TRANSMISSION AND DISTRIBUTION NETWORK SYSTEMS.... | 139 |
| SCHEDULES TO CHAPTER 5 | 159 |
| CHAPTER 6 SCHEDULING AND DISPATCH PROCESS..... | 185 |
| CHAPTER 7 POWER SYSTEM SECURITY..... | 200 |
| CHAPTER 8 DISTRIBUTION SYSTEM OPERATION | 224 |
| CHAPTER 9 GENERATION CAPACITY PLANNING AND PROCUREMENT ... | 247 |
| SCHEDULES TO CHAPTER 9 | 254 |
| CHAPTER 10 RING FENCING..... | 266 |
| CHAPTER 11 ADMINISTRATIVE FUNCTIONS | 270 |
| CHAPTER 12 TRANSITIONAL PROVISIONS..... | 296 |

PREAMBLE

Introduction

The *Government* of Kenya initiated reforms in the electricity *supply* industry in 1994. Objectives of these reforms included:-

- separating commercial functions from policy setting, regulatory and coordinating functions;
- creating more competitive conditions in the electricity *supply* industry, and
- requiring the sector companies to operate at arms length on commercial basis.

This resulted in the unbundling of the formerly vertically integrated Kenya Power and Lighting Company (KPLC) into two entities. One of the entities going by the old name of KPLC is now responsible for the *transmission, distribution* and *supply* function while the second entity called Kenya Electricity Generating Company (KenGen) took over all publicly owned *generation assets* and is responsible for *generation* in competition with *Independent Power Producers* (IPPs).

The *Electric Power Act, No 11 of 1997* (the *Act*) was enacted by Parliament as the principal *Act* governing the operation of the electricity *supply* industry in Kenya. Among other things, the *Act* provided for the establishment of the Energy Regulatory Commission (hereinafter referred to as the *Commission*) to regulate the sector, while the *Minister* for Energy is responsible for sector policy.

Statutory Instruments

The *Commission* exercises its mandate through statutory instruments among them licences, *Codes* of conduct, rules, regulations, standards, orders, and guidelines promulgated pursuant to the *Act*.

In accordance with section 115 of the *Act*, the *Commission* developed an initial draft *Grid Code* and constituted the Kenya Electricity *Grid Code* Steering Committee (KEGCSC) to review the draft. The result of that review is this *Kenya Electricity Grid Code* (hereinafter referred to as the *Grid Code* or the *Code*).

The *Grid Code* sets out detailed arrangements for the regulation of the Kenya electricity *supply* industry and is enforceable under the *Act*. Essentially the *Grid Code* is a consolidation of existing standards and practices in the Kenyan electricity *supply* industry and:

- is intended to provide a transparent regulatory framework, in line with the principle of non-discriminatory access to the *transmission* and *distribution systems*, and
- provides technical specifications and procedures which complement the *Act*.

Provisions of the Code

For the purposes of accommodating the current and evolving market structure and allocation of responsibilities to the *Code Participants*, the *Grid Code* makes the following provisions:

- (1) *Electric power producers* include KenGen, the IPPs and any future entrants.
- (2) A *System Operator* to be responsible for *dispatch* and maintaining *power system security*.
- (3) *Network service providers* responsible for operating the *transmission* and *distribution systems*.
- (4) *Public electricity suppliers* whose function is to *supply* electricity to *consumers*.

Currently KPLC is responsible for functions (2), (3) and (4) although provision is made for other future entrants as *public electricity suppliers* and *distribution network service providers*.

CHAPTER 1 INTRODUCTION, CODE OBJECTIVES AND PARTICIPANTS

1.1 INTRODUCTION

1.1.1 Citation and commencement

- (a) This *Code* may be cited as the Kenya Electricity Grid Code, or in its short form as the *Grid Code* or the *Code*.
- (b) The *Grid Code* shall come into operation on such date as the Commission may, by notice in the Gazette, appoint, and different dates may be appointed for the coming into operation of different provisions.

1.1.2 Italicised expressions

Italicised expressions and acronyms used in the *Grid Code* are defined in Chapter 2 of the *Code*.

1.2 BACKGROUND

1.2.1 Origins and development of the Kenyan electricity supply industry

- (a) The Kenyan electricity *supply* industry has grown out of the previously vertically integrated KPLC.
- (b) As part of the unbundling process, the Kenya *government* instituted structural reforms in relation to the industry in the mid 1990s.
- (c) These structural reforms have resulted in the need for a range of regulatory arrangements for the industry.

1.2.2 Origins, development and application of the Code

- (a) The *Grid Code* has been developed based on international best practice. The *Code* also deals with other matters in relation to the industry which require regulation, such as the *supply* and sale of electricity to *consumers*, *distribution system* operation and retail *metering*.
- (b) Legislation is required to support the effective operation of the *Grid Code* and to enable the *Commission* and the *System Operator* to fulfil their respective roles in relation to the industry.
- (c) The *Grid Code* is issued by the *Commission* pursuant to Section 115 of the *Act*.
- (d) The *Grid Code* is binding upon *Code Participants* pursuant to licences issued by the *Minister* in accordance with the *Act*.

1.3 INDUSTRY OBJECTIVES

The objectives of the industry are that:

- (a) any person wishing to do so should be able to gain access on fair and reasonable terms to the *transmission* and *distribution network*;
- (b) all *energy* sources or technologies should be treated in a non-discriminatory manner;
- (c) efficiency, cost-effectiveness and competition in the industry should be promoted;
- (d) a safe and efficient system of electricity *generation*, *transmission*, *distribution* and *supply* should be established and maintained;
- (e) proper environmental standards and standards of reliability and quality in the industry should be established and enforced, and
- (f) the interests of *consumers* of electricity should be protected.

1.4 CODE OBJECTIVES

The objectives for the *Grid Code* are to provide:

- (a) a regime of regulation of the industry to achieve the industry objectives;
- (b) for a set of industry-oriented rules authorised by the *Commission* governing industry operations, *power system security*, *network connection* and access and *network services* pricing;
- (c) a cost-effective framework for dispute resolution;
- (d) for adequate sanctions in cases of breaches of the *Grid Code*;
- (e) efficient processes for changing the *Grid Code*;
- (f) in respect of technical and industry operations, for the following:
 - (1) responsibilities of all *Code Participants*;
 - (2) rules for the *dispatch process* and for the purposes of producing bills and credit notes;
 - (3) detailed operational requirements, including *power system* operations and *power system security*, emergency operations, *metering*, including *metering* obligations of the *distribution network service provider*, and maintenance scheduling;
 - (4) terms and conditions of access and technical standards that will apply for *connection* to the *network*;
 - (5) the methods to be used for pricing *network services*;
 - (6) regulation of the *supply* of electricity to *consumers* and terms of *supply* to *consumers* (including methods of payment);
 - (7) regulation of the *supply* of electricity to or from the *distribution network service providers' distribution systems*; and
 - (8) general principles for ring fencing, and in particular, separating the *System Operator's* functions from the *transmission* and other functions within KPLC.

1.5 CODE PARTICIPANTS

1.5.1 General

This clause describes, applies to and sets out the obligations and responsibilities of *Code Participants*.

- (a) *Code Participants* are:
 - (1) the *Commission*;
 - (2) the *System Operator*;
 - (3) persons who carry out or who intend to carry out the *generation*, *transmission*, *distribution* and *supply* of electrical energy or any other operation for which a licence is required pursuant to the *Act* or to regulations made thereunder;
 - (4) large *consumers*;
- (b) The different *Code Participants* have different obligations under the *Grid Code*.

1.5.2 The Commission

The *Commission* is responsible for administering the *Grid Code*.

1.5.2.1 Objectives of the Commission

The objectives of the *Commission* in relation to the administration of the *Grid Code* are to:

- (a) supervise, administer and enforce the *Grid Code*;
- (b) institute and ensure through the administration and enforcement of the *Grid Code* the effective and efficient implementation of the rules and standards in the *Code*;
- (c) collect information and statistics, publish reports and disseminate information relating to the performance of the industry;
- (d) administer the ongoing development of, and *changes* to, the *Grid Code* to achieve the industry objectives;
- (e) perform any other objectives or functions conferred on it by the *Grid Code* and by legislation;
- (f) liaise effectively with other bodies having regulatory functions with respect to the industry in order to ensure consistent and effective development and application of the *Grid Code*;
- (g) to regulate the industry efficiently in accordance with the *Grid Code*; and
- (h) to promote the ongoing development of, and *changes* to, the industry with the objective of continually improving its efficiency.

1.5.2.2 Functions of the Commission

The *Commission* shall, in accordance with the provisions of the *Grid Code* and the *Act*:

- (a) monitor and report on compliance with the *Grid Code* and the adequacy of the *Code*;
- (b) enforce the *Grid Code*;
- (c) establish procedures for dispute resolution concerning the provisions of the *Grid Code*;
- (d) manage *changes* to the *Grid Code*;
- (e) establish procedures for consultation in respect of the manner in which the *Commission* fulfils its functions and obligations under the *Grid Code*;
- (f) establish, and publish annually, performance indicators to monitor its performance in respect of its objectives; and
- (g) subject to any of its obligations under the *Grid Code* or budgetary constraints, in performing its functions, use its reasonable endeavours to take into consideration the interests of *consumers* and those who are, or are likely to become, *Code Participants*.

1.5.3 The System Operator

The *System Operator* is responsible for maintaining *power system security* and for arranging the *dispatch process*.

1.5.3.1 Objectives of System Operator

The objectives of the *System Operator* are:

- (a) to facilitate and operate the *dispatch process* efficiently in accordance with the *Grid Code*;
- (b) to achieve and maintain a secure *power system* as specified in Chapter 7; and
- (c) to assist in *power system* planning in relation to the industry as specified in Chapter 3.

1.5.3.2 Functions of the System Operator

Without limitation to any of the *System Operator's* obligations under the *Grid Code*, the *System Operator* shall, in accordance with the provisions of the *Code* and the *Act*:

- (a) facilitate and operate the *dispatch of generators* in accordance with the provisions of Chapter 6 of the *Code*;
- (b) maintain *power system security* in accordance with the provisions of Chapter 7; and
- (c) assist in *power system* planning responsibilities in accordance with the provisions of Chapter 3.

1.6 LIABILITY AFTER CESSATION OF LICENCE AND PRIOR TO THE ISSUE OF A LICENCE

- (a) The fact that a person has ceased to be licensed for any reason under the *Act* does not affect any obligation or liability of that person under the *Grid Code* which arose prior to the cessation of his licence.
- (b) A *Code Participant* who is subject to a liability under the *Grid Code* which arose during the period in which he was a *Code Participant* remains subject to that liability after and despite ceasing to be a *Code Participant* regardless of when the claim is made.

1.7 INTERPRETATION

1.7.1 General

In the *Grid Code*, unless the context otherwise requires:

- (a) headings are for convenience only and do not affect the interpretation of the *Grid Code*;
- (b) words importing the singular include the plural and vice versa;
- (c) words importing a gender include any gender;
- (d) when italicised, other parts of speech and grammatical forms of a word or phrase defined in the *Grid Code* have a corresponding meaning;
- (e) an expression importing a natural person includes any company, partnership, trust, joint venture, association, corporation or other body corporate and any *government agency*;
- (f) a reference to any thing includes a part of that thing;
- (g) a reference to a chapter, condition, clause, schedule or part is to a chapter, condition, clause, schedule or part of the *Grid Code*;
- (h) a reference to any statute, regulation, proclamation, order in council, ordinances or by-laws includes all statutes, regulations, proclamations, orders in council, ordinances varying, consolidating, re-enacting, extending or replacing them and a reference to a statute includes all regulations, proclamations, orders in council, ordinances, by-laws and determinations issued under that statute;

- (i) a reference to a document or a provision of a document includes an amendment or supplement to, or replacement or novation of, that document or that provision of that document;
- (j) a reference to a person includes that person's executors, Administrators, successors, substitutes (including, without limitation, persons taking by novation) and permitted assigns;
- (k) a period of time:
 - (i) which dates from a given *day* or the *day* of an act or event is to be calculated exclusive of that *day*; or
 - (ii) which commences on a given *day* or the *day* of an act or event is to be calculated inclusive of that *day*; and
- (l) an event which is required under the *Grid Code* to occur on or by a stipulated *day* which is not a *business day* may occur on or by the next *business day*.

1.7.2 Reviewable decision

In the *Grid Code*, a decision of the *Commission* is not a reviewable decision unless it is identified as such in the *Code*.

1.8 NOTICES

1.8.1 Service of notices under the Code

A notice is properly given under the *Grid Code* to a person if:

- (a) it is personally served; or
- (b) a letter containing the notice is prepaid and posted to the person at an address (if any) supplied by the person to the sender for service of notices or, where the person is a *Code Participant*, an address shown for that person in the register of *Code Participants* to whom licences have been issued under the *Act* and maintained by the *Commission* or, where the addressee is the *Commission*, the registered office of the *Commission*; or
- (c) it is sent to the person by facsimile or electronic mail to a number or reference which corresponds with the address referred to in clause 1.8.1(b) or which is supplied by the person to the *Commission* for service of notices; or
- (d) it is published in a newspaper with wide circulation in the area where the person is resident;
- (e) it is communicated verbally to the person and that communication is recorded or thereafter confirmed in writing; or
- (f) the person receives the notice.

1.8.2 Time of service

A notice is treated as being given to a person by the sender:

- (a) where sent by post in accordance with clause 1.8.1(b) to an address in the central business district of Nairobi, on the second *business day* after the *day* on which it is posted;
- (b) where sent by post in accordance with clause 1.8.1(b) to any other address, on the third *business day* after the *day* on which it is posted;
- (c) where sent by facsimile in accordance with clause 1.8.1(c) and a complete and correct transmission report is received:

- (1) where the notice is of the type in relation to which the addressee is obliged under the *Grid Code* to monitor the receipt by facsimile outside of, as well as during, business hours, on the *day* of transmission; and
 - (2) in all other cases, on the *day* of transmission if a *business day* or, if the transmission is on a *day* which is not a *business day* or is after 4.00 pm (addressee's time), at 9.00 am on the following *business day*;
- (d) where sent by electronic mail in accordance with clause 1.8.1(c):
- (1) where the notice is of a type in relation to which the addressee is obliged under the *Grid Code* to monitor receipt by electronic mail outside of, as well as during, business hours, on the *day* when the notice is recorded as having been first received at the electronic mail destination; and
 - (2) in all other cases, on the *day* when the notice is recorded as having been first received at the electronic mail destination, if a *business day* or if that time is after 4.00 pm (addressee's time), or the *day* is not a *business day*, at 9.00 am on the following *business day*; or
- (e) where published in a newspaper in accordance with clause 1.8.1(d), on the next *day* after the date of publication of the notice;
- (f) in any other case, when the person actually receives the notice.

1.8.3 Counting of days

Where a specified period (including, without limitation, a particular number of *days*) shall elapse or expire from or after the giving of a notice before an action may be taken neither the *day* on which the notice is given nor the *day* on which the action is to be taken may be counted in reckoning the period.

1.8.4 Reference to addressee

In this clause 1.8, a reference to an addressee includes a reference to an addressee's officers, *agents*, or employees or any person reasonably believed by the sender to be an officer, *agent* or employee of the addressee.

1.9 RETENTION OF RECORDS AND DOCUMENTS

Unless otherwise specified in the *Grid Code*, all records and documents prepared for or in connection with the *Grid Code* shall be retained for a period of at least 7 years.

1.10 ACCESS UNDERTAKING

- (a) The *Grid Code* sets out details of the terms and conditions on which *network service providers* undertake to provide access to *network services*.
- (b) A *network service provider* is required as a condition of his licence to provide an access undertaking to the *Commission* as required under Chapter 3.

CHAPTER 2 ACRONYMS AND GLOSSARY**2.1 ACRONYMS**

| | |
|--------|--|
| CCP | Code Change Panel |
| CPI | Consumer Price Index |
| CT | current transformer |
| DMS | dispute management system |
| DRP | dispute resolution panel |
| EAST | East African Standard Time |
| FACTS | Flexible AC transmission system |
| HV | High Voltage |
| IEC | International Electro-technical Commission |
| KEBS | Kenya Bureau of Standards |
| KenGen | Kenya Electricity Generating Company |
| KS | Kenyan Standard |
| KPLC | Kenya Power and Lighting Company |
| kV | kilo volts |
| kVA | kilo-volt-ampere |
| LOLE | Loss of Load Expectation |
| LOR | lack of reserve |
| LRMC | Long Run Marginal Cost |
| LV | Low Voltage |
| MPI | maximum power input |
| MV | Medium Voltage |
| MVA | Mega-volt-amperes, equal to 1000 kVA |
| PASA | projected assessment of system adequacy |
| RCE | remote control equipment |
| RFP | Request for Proposals |
| RFQ | Request for Qualifications |
| RME | remote monitoring equipment |
| SPRC | System Planning and Reliability Council |
| VT | voltage transformer |
| Wh | Watt-hour |

2.2 GLOSSARY

Act means the *Energy Act, No 12 of 2006*.

active energy means a measure of electrical *energy* flow, being the time integral of the product of *voltage* and the in-phase component of current flow across a *connection point*, expressed in Watthours (Wh) and multiples thereof.

active energy meter means an integrating instrument which measures *active energy* in Watthours or in suitable multiples thereof.

active power means the rate at which *active energy* is transferred.

active power capability means the maximum rate at which *active energy* may be transferred from a *generator* to a *connection point* as specified in a *connection agreement*.

aerial bundled cable means an insulated cable manufactured to KS IEC 60050-466 used in substitution for multiple bare conductors.

agent of a person includes employee, servant, delegate or authorised representative of that person.

aggregate annual revenue requirement means the calculated total annual revenue to be earned by an entity for a defined class of service.

agreed capability, in relation to a *connection point*, means the capability to receive or send out power for that *connection point* determined in accordance with the relevant *connection agreement*.

ancillary services means those services required to facilitate the delivery of electrical *energy* to *consumers* at stable *frequencies*, and *voltages*. Such services include *frequency* regulation or control, *spinning reserves*, *voltage* and *reactive power* support, *black start* and *load shedding facilities*.

ancillary services agreement means an agreement or other arrangement (in accordance with the *Grid Code*) under which a *Code Participant* agrees to provide *ancillary services*.

annual revenue requirement means an amount representing the revenue requirement of a *network service provider* for an *asset* calculated in accordance with clause 5.4.1.

apparent energy means the time integral of the scalar product of the root mean square *voltage* and the root mean square current.

apparent power means the square root of the sum of the squares of the *active power* and the *reactive power*.

applicable regulatory instruments means all laws, regulations, orders, licences, and codes (other than the *Grid Code*) which apply to *Code Participants* from time to time including, but not limited to, the *Act*, all regulations made and *licences* issued under the *Act*, and all regulatory instruments applicable under the *licences*, to the extent that they regulate or contain terms and conditions relating to access to a *network*, *connection* to a *network*, the provision of *network services*, *network service* pricing or *reinforcement* of a *network*.

application to connect in Chapter 3, means the application made by a *connection Applicant* in accordance with clause 3.3 for *connection* to a *network* and/or the provision of *network services* or modification of a *connection* to a *network* and/or the provision of *network services*.

approved connection point means a *connection point* that has been approved by the *Commission* under clause 4.2.

associate, where the *Code Participant* is a body corporate, means each of his directors, his secretary, each of his *related bodies corporate*, and their directors and secretary.

authorised person means a person adequately trained, and possessing technical knowledge and experience and appointed in writing to carry out specific operation and/or work on the *power system*.

automatic reclose equipment in relation to a *transmission line* or *distribution line*, means the equipment which automatically recloses the relevant line's circuit breaker(s) following their opening as a result of the detection of a fault in the *transmission line* or the *distribution line* (as the case may be).

basic current has the meaning ascribed to it in KS IEC 61036 - General Purpose Induction Watthour Meters.

black start capability in relation to a *generator*, means the ability to start and *synchronise* without using electricity from the *power system*.

black start facilities mean the *facilities* described as such in clause 7.8.12(c).

black system means the absence of *voltage* on all or a significant part of the *transmission system* following a major *supply* disruption, affecting one or more *power stations* and a significant number of *consumers*.

Commission means the Energy Regulatory Commission established under section 4 of the *Act*.

books include:

- (a) a register;
- (b) accounts or accounting records, however, compiled, recorded or stored;
- (c) a document;
- (d) bankers books; and
- (e) any other record or information.

breaker fail in relation to a *protection system*, means that part of the *protection system* that protects a *Code Participant's facilities* against the non-operation of a circuit breaker that is required to open.

busbar means a common *connection point* in a *power station switchyard* or a *transmission network substation*.

business day means a *day* other than a Saturday, Sunday or a *day* which is lawfully observed as a public holiday in Kenya.

capacitor bank means electrical equipment used to generate *reactive power* and therefore support *voltage* levels on *distribution and transmission lines* in periods of high *load*.

captive in relation to *consumer*, means a *consumer* who is unable to choose his *public electricity supplier* or *network service provider*.

cascading outage means the occurrence of an uncontrollable succession of *outages*, each of which is initiated by conditions (e.g. instability or overloading) arising or made worse as a result of the event preceding it.

change includes amendment, alteration, addition or deletion.

check metering for the purposes of Chapter 9 means *metering* installed for the purpose of checking *metering equipment*.

check metering data means the *metering data* obtained from a *check metering installation*.

check metering installation means a *metering installation* used as the source of *metering data* for validation in the process of producing bills and credit notes.

clearance space means a space surrounding a *distribution powerline* which should be clear of vegetation at all times.

Code means this *Code* of conduct, called the Kenya Electricity Grid Code issued by the *Commission* in accordance with section 115 of the *Act* as the initial *Grid Code* and, if it is amended in accordance with its terms and the *Act*, the *Code* of conduct as so amended and in operation for the time being.

Code bodies means any person or body, other than the *Commission* that is appointed or constituted by the *Grid Code* to perform functions under the *Code*.

Code Change Panel (CCP) means the panel specified in clause 11.3.2(a).

Code consultation procedures means the procedures for consultation with *Code Participants* or certain groups of *Code Participants* as set out in clause 11.9.

Code objectives means the objectives of the *Grid Code* specified in clause 1.4.

Code Participant means a person bound by this *Grid Code* and includes:

- (a) the *Commission*;
- (b) the *System Operator*;
- (c) *electric power producers*
- (d) *public electricity suppliers*
- (e) large *consumers*; and
- (f) a person who holds or is deemed to hold a *licence* under the *Act*.

Code Participant Agent means an *agent* of a *Code Participant* appointed under clause 7.10.5.

commencement date means such date as the *Commission* may, in accordance with clause 1.1.1, by notice in the *Gazette*, appoint for the coming into operation of this *Grid Code*.

commitment means the commencement of the process of starting up and *synchronising* a *generator* to the *power system*.

common service means a service that ensures the integrity of a *transmission* or *distribution system* and benefits all *Network users* and cannot reasonably be allocated to *Network users* on a locational basis.

communication link means all communication equipment and arrangements that lie between the *meter/data logger* and the public telecommunications network.

complainant means the party which refers a dispute to the *Dispute Resolution Panel* in accordance with clause 11.2.5(a).

conductor size in relation to the sizes utilised in Tables 2 and 3 in Chapter 8.6 means:

small - all conductors up to and including 8mm diameter e.g. 3/2.75 SC/GZ, 3/12 SC/GZ, 7/.064 Cu, 7/2.50 AAC.

medium - all conductor diameters within the range from, but not including, 8mm up to and including 14mm e.g. 7/3.00 AAAC, 6/1/3.00 ACSR, 7/3.75 AAC, 19/.064 Cu.

large - all conductors over 14mm in diameter e.g. 19/3.25, 6/4.75-7/1.60.

confidential information in relation to a *Code Participant*, means information which is or has been provided to that *Code Participant* under or, in connection with the *Grid Code* and which is stated under the *Code* or by the *Commission* to be *confidential information* or otherwise confidential or commercially sensitive or information which is derived from any such information.

connect, connected, connection means to form a physical link to or through a *transmission network* or *distribution network* such as will allow the *supply* of electricity between electrical systems.

connection agreement means an agreement between a *network service provider* and a *Code Participant* or other person by which the *Code Participant* or other person is *connected* to the *transmission* or *distribution network* and/or receives *transmission services* or *distribution services*.

connection applicant means a person who wants to establish or modify *connection* to a *transmission network* or *distribution network* and/or who wishes to receive *network services* and who makes a *connection* enquiry as described in clause 3.3.2.

connection assets means those components of a *transmission* or *distribution system* which are used to provide *connection services*.

connection point means the agreed point of *supply* established between *network service provider(s)* and another *Code Participant* or *consumer*.

connection service means an *entry service* (being a *transmission* or *distribution service* provided to serve an *electric power producer* or group of *electric power producers* at a single *connection point*) or an *exit service* (being a *transmission* or *distribution service* provided to serve a *Transmission* or *Distribution consumer* or group of *Transmission* or *Distribution consumers* at a single *connection point*).

conservation includes preservation, maintenance, sustainable use and restoration of natural and cultural environment.

constrained off in respect of a *generator*, means the state where, due to a *constraint* on a *network* the output of that *generator* is limited below the level to which it would otherwise have been *dispatched* by the *System Operator* on the basis of its *dispatch information*.

constrained on in respect of a *generator*, means the state where due to a *constraint* on a *network*, the output of that *generator* is limited above the level to which it would otherwise have been *dispatched* by the *System Operator* on the basis of its *dispatch information*.

constraint, constrained means a limitation on the capability of a *network*, *load* or a *generator* such that it is unacceptable to either transfer, consume or generate the level of electrical power that would occur if the limitation was removed.

construction includes reconstruction, replacement or making structural *changes*.

Consultant in clause 11.6.2(b), means a legal or other professional adviser, auditor or other consultant.

consulting party means the person who is required to comply with the *Code consultation procedures*.

consumer means a *consumer* who is *supplied* with electricity or has made an application for *supply* under section 28 of the *Act* and, for the purposes of Part B of Chapter 9, includes *electric power producers* who consume electricity *supplied* to them from the *Kenyan network*.

contestable in relation to *transmission services or distribution services*, means a service which is permitted by the laws of Kenya to be provided by more than one *network service provider* as a *contestable service* or on a competitive basis.

contestable consumer in relation to a *consumer* means a *consumer* who is not *captive* and who may be supplied with electrical *energy* by more than one *public electricity supplier* or *network service provider* on a competitive basis.

contingency capacity reserve means actual *active* and *reactive energy* capacity, *interruptible load* arrangements and other arrangements organised to be available to be utilised on the actual occurrence of one or more *contingency events* to allow the restoration and maintenance of *power system security*.

contingency capacity reserve standards means the standards set out in the *power system security and reliability standards* to be used by the *System Operator* to determine the levels of *contingency capacity reserves* necessary for *power system security*.

contingency event means an event described in clause 7.2.3(a).

control centre means the *facility* used by the *System Operator* for directing the minute to minute operation of the *power system*.

control system is the means of monitoring and controlling the operation of the *power system* or equipment including *generators connected to a transmission or distribution network*.

cost pool means a pool used to collect the costs associated with the use of *asset* categories by a group of *distribution network users* with like *load, metering* and *voltage* characteristics for the purpose of preparing *distribution service prices*.

cost reflective network pricing means a cost allocation method which reflects the value of *assets* used to provide *transmission or distribution services* to *Network users*.

coupling point means the point at which *connection assets* join on a *network*. It is used to identify the *use of system price* applicable to a *network user*.

CPI means the Consumer Price Index published by the Central Bureau of Statistics of Kenya for the March quarter immediately preceding the start of the relevant year.

credible contingency event means an event described in clause 7.2.3(b), certain examples of which are set out in schedule 3.1.

critical single credible contingency event means an event described in clause 7.2.3(d).

current rating means the maximum current that may be permitted to flow (under defined conditions) through a *transmission line* or other item of equipment that forms part of a *power system*.

current transformer (CT) means a *transformer* for use with *meters* and/or protection devices in which the current in the secondary winding is, within prescribed error limits, proportional to and in phase with the current in the primary winding.

current transformer for the purposes of Chapter 9, has the meaning ascribed to it in IEC 60044-1.

Customer Charter means the document referred to as such in clause 4.2 of the *Grid Code*.

data collection system means all equipment and arrangements that lie between the *metering database* and the point where the *metering data* enters the public telecommunications network.

data logger means a device that collects *energy data*, packages it into 30 minute intervals (or sub-multiples), holds a minimum of 35 *days* of data, and is capable of being accessed electronically by the relevant *Code Participant* via the *data collection system*. This device may be a separate item of equipment, or combined with the *energy* measuring components within one physical device.

day, unless otherwise specified, means the 24 hour period beginning and ending at midnight East African Standard Time (EAST).

decommission, de-commit in respect of a *generator*, means ceasing to generate and *disconnecting* from a *network*.

defective in relation to,

- (a) *new metering equipment*, means that the *new metering equipment* is not meeting the *minimum standards*; and
- (b) *existing metering equipment*, means that the *existing metering equipment* is not meeting the minimum standards of accuracy which it was designed to meet.

delayed response capacity reserve means that part of the *contingency capacity reserve* capable of realisation within 5 minutes of a major *frequency* decline in the *power system* as described further in the *power system security and reliability standards*.

demand means the rate at which electrical *energy* is delivered or used over a specified period, usually expressed in kW or kVA or multiples thereof such as MW or MVA, or other suitable units.

demand integration period means the interval of time upon which the *demand* measurement is made.

deprival value means a value ascribed to *assets* which is the lower of economic value or optimised depreciated replacement value.

de-synchronising/de-synchronisation means the act of *disconnection* of a *generator* from the *connection point* with the *power system*, normally under controlled circumstances.

direct connected meter means a *meter* connected directly to the *electrical installation* being *metered*, without an external *current transformer*.

direct metered electrical installation means an *electrical installation* metered by a *direct connected meter*.

direction means a direction issued by the *System Operator* to any *Code Participant* requiring the *Code Participant* to do any act or thing which the *System Operator* considers necessary to maintain or re-establish the *power system security* in accordance with clause 7.8.10. or clause 11.5.9 or to maintain or re-establish the *power system* in a *reliable operating state* in accordance with clause 7.8.6.

Disaster Preparedness and Management Committee means the committee established under the Office of the President to deal with national disasters.

disclosee in relation to a *Code Participant*, means a person to whom that *Code Participant* discloses *confidential information*.

disconnection, disconnect means the operation of switching equipment or other action so as to prevent the flow of electricity at a *connection point*.

dispatch means the process of precisely matching the outputs of *generators* with *load* in real time in accordance with clause 6.3.

dispatch inflexibility profile means data which may be provided to the *System Operator* by *electric power producers*, in accordance with clause 6.3.9, to specify *dispatch* inflexibilities in respect of *generators*.

dispatch information means the information submitted by an *electric power producer* in accordance with clause 6.3.2(b).

dispatch instruction means an instruction given to an *electric power producer* under clauses 3.3.11 in relation to the *dispatch* of a *generator*.

dispatch process means the process managed by the *System Operator* for the *dispatch* of *generators* in accordance with clause 6.3.

distribute in relation to electricity, means to distribute electricity using a *distribution system*.

dispute management system (“DMS”) means the dispute management system which each *Code Participant* shall adopt in accordance with clause 11.2.2.

dispute resolution panel (“DRP”) means the dispute resolution panel established pursuant to clause 11.2.6.

distribution means the conveyance of electricity through a *distribution system*.

distribution area in relation to a *distribution network service provider*, means the area in which the *distribution network service provider* is licensed to *distribute* electricity under Part 4 of the *Act*.

distribution consumer means a *consumer*, *distribution network service provider* and a *consumer* having a *connection point* with a *distribution network*.

distribution licence means a *licence* to *distribute* and *supply* electricity granted under the *Act*.

distribution line means a power line, including under ground cables, that is part of a *distribution network*.

distribution losses means *electrical energy losses* incurred in distributing electricity over a *distribution network*.

distribution network means a *network* which is not a *transmission network*.

distribution network service provider means a person who engages in the activity of owning, controlling, or operating a *distribution system*, and in relation to:

- (a) a *consumer* or a *consumer's electrical installation*; or
- (b) an *embedded generator* or an *electric power producer* with an *embedded generator*,
the *distribution network service provider* in whose *distribution area* that *consumer's electrical installation* or that *embedded generator* or *electric power producer's embedded generator* (as the case may be) is located.

distribution network user means a *distribution consumer* or an *electric power producer*.

distribution powerline means an overhead *electric supply line*, operated by a *distribution network service provider*.

distribution service means the services provided by a *distribution system* which are associated with the conveyance of electricity through the *distribution system*. *Distribution services* include *entry services*, *distribution network use of system services* and *exit services*.

distribution system means a *distribution network*, together with the *connection assets* associated with the *distribution network*, which is *connected* to another *transmission* or *distribution system*. *Connection assets* on their own do not constitute a *distribution system*.

distribution system control centre means the *facility* used by a *Distribution System Operator* for directing the minute to minute operation of the relevant *distribution system*.

distribution use of system, distribution use of system service means a service provided to a *distribution network user* for use of the *distribution network* for the conveyance of electricity that can be reasonably allocated on a locational and or *voltage* basis.

dynamic performance means the response and behaviour of *networks* and *facilities* which are *connected* to the *networks* when the *satisfactory operating state* of the *power system* is disturbed.

electric supply line means a wire or wires or conductor or other means used for the purpose of transmitting or distributing electricity with any casing, coating, covering, tube, pipe, pole, post, frame, bracket or insulator enclosing, surrounding or supporting the same or any part thereof or any apparatus *connected* therewith for the purpose of transmitting or distributing electricity or electric currents.

electric power producer means a person who engages in the activity of owning, controlling, or operating a *generating system* that *supplies* electricity to, or who otherwise *supplies* electricity to, a *transmission* or *distribution system* and who holds or is deemed to hold a *licence* or has been exempted from the requirement to obtain a *licence* under a regulation of the *Act*.

electrical connection means a point to which a *consumer* may *connect* the *consumer's electrical installation* for the purpose of receiving electricity *supply* from a *distribution network*.

electrical energy loss means the *energy* loss incurred in the production, transportation and/or use of electricity.

electrical infrastructure has the meaning ascribed to it in the *Act*.

electrical installation means any electrical equipment that is fixed (or to be fixed) in, on, under or over a *consumer's* premises, but does not include:

- (a) any electrical *supply* main or service line of a *distribution network service provider*;
- (b) any electrical equipment:
 - (1) that is fixed (or to be fixed) in, on, under or over any premises owned or occupied by a *distribution network service provider*; and
 - (2) that is not used:
 - (A) for the consumption of electricity on those premises; or
 - (B) solely for purposes incidental to that consumption;
- (c) any *connections* to a *consumer's* terminals for the purpose of providing *electrical energy*; or
- (d) any *metering* equipment owned by a *distribution network service provider*.

electricity account means an account for electricity *supplied*.

electronic communication system includes the electronic communication and the electronic *data transfer* system provided to *Code Participants*.

electronic data transfer means the transfer of data by electronic means from one location to another.

embedded generator means a *generator connected* within a *distribution network* and not having direct access to the *transmission network*.

energise/energisation means the act of operation of switching equipment or the start-up of a *generator*, which results in there being a non-zero *voltage* beyond a *connection point* or part of the *transmission or distribution network*.

energy means *active energy* and/or *reactive energy*.

energy constrained generator means a *generator* in respect of which the amount of electricity it is capable of *supplying* on a *day* is less than the amount of electricity it would *supply* on that *day* if it were *dispatched* to its full nominated availability for the whole *day*.

energy data means the data that result s from the measurement of the flow of electricity in a power conductor. The measurement is carried out at a *metering point*.

energy packets means the value of *energy data* which is accumulated for a period of 30 minutes and stored as a separate data record.

entry price means the price payable by an *electric power producer* to a *network service provider* for *entry service* at a *connection point*.

entry service means a *transmission or distribution service* provided to serve an *electric power producer or group of electric power producers* at a *single connection point*.

equivalent energy means the amount of *energy* determined by cost reflective *network pricing* to have been transported by a *transmission network* to all *transmission consumers*.

excitation control system In relation to a *generator*, means the automatic control system that provides the field excitation for the *generator* of the *generator* (including excitation limiting devices and any *power system stabiliser*).

excluded distribution services means *Distribution services* the costs of and revenue for which are excluded from the price control which applies to *prescribed distribution services*.

existing metering equipment means *metering equipment* installed before the *commencement date*.

exit services means a service provided to serve a *transmission* or *distribution consumer* or group of *transmission* or *Distribution consumers* at a single *connection point*.

extension means a *reinforcement* that requires the *connection* of a power line or *facility* outside the present boundaries of the *transmission* or *distribution network* owned or operated by a *network service provider*.

extreme frequency excursion tolerance limits in relation to the *frequency* of the *power system*, means the limits so described and specified in the *power system security and reliability standards*.

facility means a generic term associated with the apparatus, equipment, buildings and necessary associated supporting resources provided at, typically:

- (a) a *power station* or *generator*, including *black start facilities*;
- (b) a *substation* or *power station switchyard*;
- (c) a *control centre* (*control centre* or *distribution* or *transmission control centre*);
- (d) *facilities* providing an *exit service*.

financial year means a period commencing on 1 July in one calendar year and terminating on 30 June in the following calendar year.

fire control authority means any Fire Service under the control of any local, or public authority or any other person in Kenya.

fire hazard rating means a rating assigned by the *fire control authority* designating propensity for ignition and spread of fire.

forecast load (as generated) means a forecast to be provided, as described in clause 6.1(b).

forecast load (sent out) means a forecast to be provided, as described in clause 6.1(b).

frequency for alternating current electricity, means the number of cycles occurring in each second. The term Hertz (Hz) corresponds to cycles per second.

frequency operating standards means the standards which specify the frequency levels for the operation of the *power system* set out in the *power system security and reliability standards*.

frequency response mode means the mode of operation of a *generator* which allows automatic changes to the generated power when the *frequency* of the *power system* changes.

generated in relation to a *generator*, means the amount of electricity produced by the *generator* as measured at its terminals.

generating plant in relation to a *connection point*, includes all equipment involved in generating electrical *energy*.

generating system means a system comprising one or more *generators*.

generator means the actual *generator* of electricity and all the related equipment essential to its functioning as a single entity.

generation means the production of electrical *energy* by converting another form of *energy* in a *generator*.

generation licence means a *licence* to generate electricity for *supply* or sale granted under Part 3 of the *Act*.

generator access means a level and standard of service of *power transfer capability* of the *transmission network* and/or *distribution network* in respect of the *electric power producer's generators* or group of *generators* at a *connection point* which has been negotiated between the *electric power producer* and the relevant *network service provider*.

good electricity industry practice means the exercise of that degree of skill, diligence, prudence and foresight that reasonably would be expected from operators of *facilities* forming part of the *power system* for the *generation, transmission* or *supply* of electricity under conditions comparable to those applicable to the relevant *facility* consistent with applicable laws, regulations, licences, *Codes, reliability, safety* and environmental protection. The determination of comparable conditions is to take into account factors such as the relative size, duty, age and technological status of the relevant *facility* and the applicable laws, regulations, licences and *Codes*.

government means the *government* of the Republic of Kenya.

governor system means the automatic *control system* which regulates the speed of the power turbine of a *generator* through the control of the rate of entry into the *generator* of the primary *energy* input (for example, steam, gas or water).

grid means the *network* of *transmission systems, distribution systems* and *connection points* for the movement and *supply* of electrical *energy* from *electric power producers' generators* to *consumers*.

half hour metering equipment means equipment capable of measuring and recording electricity *supplied* to an *electrical installation* in thirty minute intervals commencing and ending on the hour or thirty minutes past the hour according to East African Standard Time, including communications equipment, clocks and *current* or *voltage transformers*, which equipment complies with the requirements for *metering installations* at *approved connection points* in accordance with Chapter 4.

hazard space means the space out side the *clearance space* and *re-growth space* in which trees or limbs due to their unsafe condition are a potential hazard to the safety of a *distribution power line* under the range of weather conditions that can reasonably be expected to prevail.

high to very high fire risk area means an area for which the *fire control authority* has allocated a *fire hazard rating* of “high” or “very high”.

high voltage (HV) means a nominal *voltage* above 33 kilovolts.

impulse voltage means a withstand *voltage* as described in KS IEC 60071.

industry means the industry in Kenya involved in the *generation, transmission, distribution, supply* and sale of electricity.

industry objectives means the objectives of the Kenyan electricity industry set out in clause 1.3.

Independent Power Producers (IPP) means *electric power producers* who sell their outputs to *public electricity suppliers* under contracts, often life-of-plant contracts.

individual contract means a contract for the sale of electricity to a *consumer* negotiated under the *Act*.

inflexible in respect of a *generator* for a *scheduling interval* means that the *generator* is only able to be *dispatched* in the *interval* at a fixed *loading level* specified in accordance with clause 6.3.9(a).

instrument transformer means either a *current transformer (CT)* or a *voltage transformer (VT)*.

insulated service cable means a *low voltage* multi-core cable insulated by a medium other than an air space as defined in KS IEC 60071 as amended or replaced from time to time, and used for the purpose of conveying electricity through a *service line*.

interconnection capacity reserve contribution considerations means the considerations regarding contributions to *capacity reserve* available from *interconnections* described in the *power system security and reliability standards*.

interconnection, interconnector, interconnect, interconnected means a *transmission line* or group of *transmission lines* that connects the *transmission network* in one region or jurisdiction to another region or jurisdiction.

interested party In Chapter 11, means a person, not being a *Code Participant*, who in the *Commission's* opinion, has or who identifies itself to the *Commission* as having an interest in *changes* to the *Grid Code*.

intermittent means a description of a *generator* whose output is not readily predictable, including, without limitation, solar *generators*, wave turbine *generators*, wind turbine *generators* and hydro-*generators* without any material storage capability.

interruptible load means a *load* which is able to be *disconnected*, either manually or automatically initiated, which is provided for the restoration or control of the *power system frequency* by the *System Operator* to cater for *contingency events* or shortages of *supply*.

isolation Electrical isolation of one part of a communication system from another but where the passage of *electronic data transfer* is not prevented.

Kenyan Standard (KS) means the most recent edition of a standard publication by Kenya Bureau of Standards.

lack of reserve (LOR) means any of the conditions described in clause 7.8.5.

licence means a licence issued by the *Minister* pursuant to Part 1 of the *Act* or deemed to be held by an electricity entity pursuant to regulations made under the *Act*.

load means a *connection point* or defined set of *connection points* at which electrical power is delivered to a person or to another *network* or the amount of electrical power delivered at a defined instant at a *connection point*, or aggregated over a defined set of *connection points*, and for the purposes of Chapter 8:

- (a) in relation to a *public electricity supplier*, the *energy* required by a *consumer* to whom the *public electricity supplier* sells electricity, in respect of an *electrical installation*; and

(b) in relation to an *embedded generator*, the *energy supplied* or to be *supplied* by an *embedded generator* of the *electric power producer* to the *distribution network service provider's distribution system*; and

(c) in relation to a *consumer*, the *energy supply* required by the *consumer* in respect of an *electrical installation*.

load centre means a geographically concentrated area containing *load* or *loads* with a significant combined consumption capability.

load shedding means reducing or disconnecting *load* from the *power system*.

loading level means the level of output or consumption (in MW) of a *generator* or *load*.

local black system procedures means the procedures, described under clause 7.8.13 applicable to a *supply area* as approved by the *System Operator*.

loss factor is multiplier used to describe the additional *electrical energy loss* for each increment of electricity used or transmitted.

low reserve means the conditions described in clause 7.8.5(a).

low to moderate fire risk area means an area which:

(a) will not be given a *fire hazard rating* by the *fire control authority*; or

(b) has been given a *fire hazard rating* of “low” or “moderate” by the *fire control authority*.

low voltage (LV) means a nominal *voltage* of less than 1 kilovolt.

market rules specify commercial arrangements in the electricity market. The *market rules* will typically cover the following areas:

(a) the form and frequency of *generator* price and quantity nominations ("bids");

(b) any arrangements for the regulation of these bids;

(c) procedures for the determination of the spot price;

(d) procedures for the computation of charges and payments;

(e) system settlement and invoicing;

(f) accounting arrangements;

(g) provisions for the administration and amendment of the market rules; and

(h) dispute resolution procedures.

maximum demand means the highest amount of electrical power delivered, or forecast to be delivered, over a defined period (hour, half hour, quarter hour) either at a *connection point*, or simultaneously at a defined set of *connection points*.

maximum power input (MPI) means the largest single *supply* input to a particular location, typically the output of the largest single *generator* or group of *generators* or the highest *power transfer* of a single *transmission line* or *interconnection*.

medium term capacity reserve means the amount of surplus generating capacity indicated as being available for a particular period, being more than 7 *days* in the future, assessed as being in excess of the capacity requirement to meet the forecast *load*, taking into account the known or historical levels of *demand* management.

medium term capacity reserve standard means the level of *medium term capacity reserves* required for a particular period as set out in the *power system security and reliability standards*.

medium term PASA means the PASA in respect of the period from the 8th *day* after the current *day* to 24 months after the current *day* in accordance with clause 6.2.2.

medium voltage (MV) means a nominal *voltage* of more than 1 kilovolt but not more than 33 kilovolts.

meter means a device complying with *Kenyan Standards* which measures and records the production or consumption of electrical *energy*.

metering, metered means recording the production or consumption of electrical *energy*.

metering data means the data obtained from a *metering installation*, the processed data or substituted data and for the purposes of Chapter 9, the records of data stored in *metering equipment* collected by a *distribution network service provider* under clause 9.6.2.

metering database means a database of *metering data* controlled by a *Code Participant*.

metering equipment means equipment installed or to be installed to safely measure, record and, in certain cases, collect and read records of the amount of electricity (in the nature of *apparent energy* and *reactive energy*) *supplied* from a *distribution network service provider's distribution system* to an *electrical installation* of a *consumer* including *meters, current transformers* and *voltage transformers*, wiring and any computing or communications equipment designed to facilitate electronic access and in the case of a *consumer* that has installed *half hour metering equipment* means *half hour metering equipment*.

metering installation means the assembly of components between the *metering point(s)* and the point of connection to the public telecommunications network. This may include the combination of several *metering points* to derive the *metering data* for a *connection point*.

metering interval means thirty (30) minute time periods.

metering point means the point of physical *connection* of the device measuring the current in the power conductor.

metering system means the collection of all components and arrangements installed or existing between each *metering point* and the *metering database*.

minimum standards means in respect of *new metering equipment*, means the minimum standards referred to in clause 9.11.

Minister means the minister for the time being responsible for Energy.

monitoring equipment means the testing instruments and devices used to record the performance of *plant* for comparison with expected performance.

monitoring objectives means the objectives specified in clause 11.7.1.

month, unless otherwise specified, means the period of beginning at 11 midnight on the relevant commencement date and ending at 11 midnight on the date in the next calendar month corresponding to the commencement date of the period.

multiple contingency capacity reserve requirements means the levels of *contingency capacity reserves* required to be available to respond to multiple *critical*

credible contingency events as set out in the *power system security and reliability standards*.

nameplate rating means the maximum continuous output or consumption in MW of an item of equipment as specified by the manufacturer.

network means the apparatus, equipment, *plant* and buildings used to convey, and control the conveyance of, electricity to *consumers* (whether wholesale or retail) excluding any *connection assets*. In relation to a *network service provider*, a *network* owned, operated or controlled by that *network service provider*.

network capability means the capability of the *network* or part of the *network* to transfer electricity from one location to another.

network connection means the formation of a physical link between the *facilities* of two *Code Participants* or a *Code Participant* and a *consumer* being a *connection* to a *transmission* or *distribution network* via *connection assets*.

network constraint means a *constraint* on a *transmission network* or *distribution network*.

network losses means *energy* losses incurred in the transfer of electricity over a *transmission network* or *distribution network*.

network owner means the owner of a *transmission network* or a *distribution network*.

network service *transmission service* or *distribution service* associated with the conveyance and controlling the conveyance, of electricity through the *network*.

network service provider means a person who engages in the activity of owning, controlling, or operating a *transmission or distribution system* and who holds or is deemed to hold a *licence* or has been exempted from the requirement to obtain a *licence* under a regulation of the *Act*.

network user means an *electric power producer*, a *transmission consumer* or a *distribution consumer*.

new metering equipment means *metering equipment* installed or to be installed, or *existing metering equipment* reconditioned, on or after the *commencement date*.

nomenclature standards means the standards approved by the *System Operator* in conjunction with the *network service providers* relating to numbering, terminology and abbreviations used for information transfer between *Code Participants* as provided for in clause 7.11.

non-credible contingency event means an event described in clause 7.2.3(e).

normal operating frequency band means in relation to the *frequency* of the *power system*, means the range so specified in the *power system security and reliability standards*.

normal operating frequency excursion band means in relation to the *frequency* of the *power system*, means the range specified as being accept able for infrequent and momentary excursions of *frequency* outside the *normal operating frequency band* being the range so specified in the *power system security and reliability standards*.

occupier means in relation to land, a person who is in actual occupation of the land or if no one is in actual occupation of the land, the *owner* of the land.

operational communication means a communication concerning the arrangements for, or actual operation of the *power system* in accordance with the *Grid Code*.

outage means any full or partial unavailability of equipment or *facility*.

owner means in the case of *public land*, means the person responsible for administering that land.

peak load means maximum *load*.

physical plant capability means the maximum MW output or consumption which an item of electrical equipment is capable of achieving for a given period.

planning statement means a statement prepared by and *published* by the *System Operator* to provide information to assist *Code Participants* in making an assessment of the future need for electricity generating or *demand* management capacity or *reinforcement* of the *power system*.

plant means in relation to a *connection point*, includes all equipment involved in generating, utilising or transmitting electrical *energy*.

point of connection in relation to an *embedded generator*, means the point at which the *embedded generator* is *connected* to the *distribution network service provider's distribution system*.

point of supply in relation to an *electrical installation*,

- (a) in the case of an *electrical installation supplied* by an underground *electric supply line*, the load-side terminals of the service protection equipment at the end of the underground *electric supply line*; and
- (b) in the case of an *electrical installation supplied* by an overhead *electric supply line*, the first *point of connection* of that *electric supply line* on the land, being:
 - (1) where the *electric supply line* is carried onto the land by one or more poles, the first pole on the land carrying that *electric supply line*;
 - (2) where the *electric supply line* is *connected* directly to premises on that land, that *connection* to the premises; or
 - (3) where it is not possible to determine a *point of supply* in accordance with (1) or (2) above, the point at which the *electric supply line* crosses the boundary of the land.

postage stamp basis means the system of charging *network users* for *transmission service* or *distribution service* in which the price per unit is the same regardless of how much *energy* is used by the *network user* or the location in the *transmission network* or *distribution network* of the *network user*.

power factor ($\cos \phi$) is the ratio of the *active power* to the *apparent power* at a *metering point*, and for the purposes of Chapter 8, in respect of a thirty minute period, means the factor calculated as follows:

$$\cos \phi = \frac{A}{B}$$

where:

A is the *energy* delivered in the thirty minute period; and

B is the *apparent energy* delivered in the thirty minute period.

power station means in relation to an *electric power producer*, a *facility* in which any of that *electric power producer's generators* are located.

Power Purchase Agreement (PPA) means a contract, usually long-term, between parties for the sale of electrical *energy* at predetermined prices or price formulae.

power system means the electricity *power system* of the Kenyan *network* including associated *generation* and *transmission and distribution networks* for the *supply* of electricity in Kenya, operated as an integrated *system* or otherwise.

power system damping means the rate at which disturbances to the *satisfactory operating state* reduce in magnitude.

power system demand means the total *load* (in MW) supplied by the *power system*.

power system operating procedures means the procedures to be followed by *Code Participants* in carrying out operations and /or maintenance activities on or in relation to primary and *secondary equipment connected to or forming part of the power system or connection points*, as described in clause 7.9.1.

power system reserve constraint means a *constraint* in the *dispatch* due to the need to provide or maintain a specified type and level of *reserve*.

power system security means the safe scheduling, operation and control of the *power system* on a continuous basis in accordance with the principles set out in clause 7.2.6.

power system security responsibilities means the responsibilities of the *System Operator* set out in clause 7.3.1.

power system security and reliability standards means the standards governing *power system security* and *reliability* of the *power system* to be approved by the *System Planning and Reliability Council* on the advice of the *System Operator*, which may include but are not limited to standards for the *frequency* of the *power system* in operation, *contingency capacity reserves* (including guidelines for assessing requirements and utilisation), *short term capacity reserves* and *medium term capacity reserves*.

power transfer means the instantaneous rate at which *active energy* is transferred between *connection points*.

power transfer capability means the maximum permitted *power transfer* through a *transmission or distribution network* or part thereof.

pre-dispatch means the forecast of *dispatch* performed one *day* before the *day* on which *dispatch* is scheduled to occur.

pre-dispatch schedule means a schedule prepared in accordance with clause 6.3.10.

preliminary program means the program to be prepared by a *network service provider* showing proposed milestones for *connection* and access activities as specified in clause 6.3.3(b)(4).

prepayment meter means a *meter* that permits the *supply* of electricity under arrangements which entail payment in full therefor in advance of its consumption, and the recovery of sums owing to the *public electricity supplier* by a periodic debit from the meter as agreed between the *public electricity supplier* and the *consumer*.

prepayment metering installations means an assembly of *prepayment meters*, *current transformers*, *voltage transformers* and any other *metering equipment* required

to measure, record, collect and manage *consumers'* consumption data and payments.

prescribed distribution services means *distribution services* provided by *distribution network assets* or associated *connection assets* which are determined by the *Commission* as those which should be subject to economic regulation under clause 5.10.4(a).

prescribed services means the services specified in a *transmission* revenue requirement determination.

price controls means the method of price control for *transmission network service providers* and *distribution network service providers* adopted by the *Commission* pursuant to clauses 5.2.3(b) and 5.5.5(b).

profile with respect to the output from a *generator*, the electricity consumption by a *load* or *power system demand*, means the quantification in MW of the variation of that output, consumption or *demand* over a given period.

projected assessment of system adequacy (“PASA”) process means the medium term and short term processes described in clause 6.2 to be administered by the *System Operator*.

protection system means a system, which includes equipment, used to protect a *Code Participant's facilities* from damage due to an electrical or mechanical fault or due to certain conditions of the *power system*.

pruning and clearing cycle means the frequency of successive pruning or clearing which the *distribution network service provider* judges as optimal for maintaining the *clearance space* taking account of recurrent costs, community values, negotiation with the landowner, and utility and amenity in the area.

public electricity supplier means an electricity entity with an exclusive right under his licence to sell electricity to *consumers* within a particular *supply area* or a person who has been exempted from the requirement to obtain a licence under a regulation of the *Act*.

public land means land belonging to a public or local authority as defined in the *Land Act*.

public lighting means street lighting provided by a governmental body or agency in Kenya.

publish/publication means make available to *Code Participants* electronically.

pumping load means electrical power consumed by electrically operated pumps.

ramp rate means the rate of *change* of electricity produced from a *generator*.

rated current has the meaning ascribed to it in (Specify the appropriate standard).

reactive energy means a measure, in varhours (varh) of the alternating exchange of stored *energy* in inductors and capacitors, which is the time-integral of the product of *voltage* and the out-of-phase component of current flow across a *connection point*.

reactive energy meter means a *meter* used to measure *reactive energy*.

reactive plant means *plant* which is normally specifically provided to be capable of providing or absorbing *reactive power* and includes the *plant* identified in clause 7.5.1(g).

reactive power means the rate at which *reactive energy* is transferred. *Reactive power* is a necessary component of alternating current electricity which is separate from *active power* and is predominantly consumed in the creation of magnetic fields in motors and *transformers* and produced by *plant* such as:

- (a) alternating current *generators*;
- (b) capacitors, including the capacitive effect of parallel *transmission* wires; and
- (c) *synchronous condensers*.

reactive power capability means the maximum rate at which *reactive energy* may be transferred from a *generator* to a *connection point* as specified in a *connection agreement*.

reactive power reserve means unutilised sources of *reactive power* arranged to be available to cater for the possibility of the unavailability of another source of *reactive power* or increased requirements for *reactive power*.

reactive power support/ reactive support means the provision of *reactive power*.

reactor means a device, similar to a *transformer*, specifically arranged to be *connected* into the *transmission system* during periods of low *load demand* or low *reactive power demand* to counteract the natural capacitive effects of long *transmission lines* in generating excess *reactive power* and so correct any *transmission voltage* effects during these periods.

regrowth space means the space beyond the *clearance space* that should be cleared to allow for anticipated vegetation regrowth for the period of the *pruning and clearing cycle*.

regulating capability means the capability to perform *regulating duty*.

regulating capability constraints means *constraints* on the formulation of a realisable *dispatch* or *pre-dispatch schedule* due to the need to provide for *regulating capability*.

regulating duty in relation to a *generator*, means the duty to have its generated output adjusted frequently so that any *power system frequency* variations can be corrected.

regulations means any regulations made under the *Act*.

regulatory control period in parts B and C of Chapter 5, means a period during which a *transmission* revenue cap determination made under the *Electricity Supply Industry (Price Control) Regulations 2003* is in effect, and in Parts D & E of Chapter 5, a period in which a *price control* is imposed on a *distribution network service provider* by the *Commission*.

regulatory test means the test promulgated by the *Commission* in accordance with clause 3.6.3(k) for the purposes of clause 3.6.3 and clause 11.8.1.

reinforce, reinforcement means works to enlarge a *network* or to increase the capability of a *network* to transmit or distribute *active energy*.

related body corporate in relation to a body corporate, means a body corporate that is related to the first-mentioned body by virtue of the Corporations Law.

reliability means the probability of a system, device, *plant* or equipment performing its function adequately for the period of *time* intended, under the operating conditions encountered.

reliable means the expression of a recognised degree of confidence in the certainty of an event or action occurring when expected.

reliable operating state in relation to the *power system*, has the meaning set out in clause 7.2.7.

remote control equipment (RCE) means equipment used to control the operation of elements of a *power station* or *substation* from a *control centre*.

remote monitoring equipment (RME) means equipment installed to enable monitoring of a *facility* from a *control centre*.

representative in relation to a person, means any employee, officer, servant, *agent* or *Consultant* of:

- (a) that person; or
- (b) a *related body corporate* of that person; or
- (c) a third party contractor to that person.

reserve means *short term capacity reserve* and *medium term capacity reserve* as required in accordance with the *power system security and reliability standards*.

responsible person means the person who has responsibility for the provision of a *metering installation* for a particular *connection point*, being either the *Local network service provider* or the *electric power producer* or *public electricity supplier* as described in Chapter 4.

revenue cap in Parts B and C of Chapter 5, means the maximum revenues specified by the *Commission* for *prescribed services* in a *transmission* revenue cap determination made under the *Electricity Supply Industry (Price Control) Regulations 2003* applicable to a *transmission network owner* or *transmission network service provider* (as applicable). In Parts D and E of Chapter 5, the *aggregate annual revenue requirement* for a year determined by the *Commission* applicable to a *distribution network service provider*.

revenue meter means the *meter* that is used for obtaining the primary source of *metering data*.

revenue metering data means the *metering data* obtained from a *revenue metering installation*.

revenue metering installation means a *metering installation* used as the primary source of *metering data* for the *settlements* process.

revenue metering point means the *metering point* at which the *revenue metering installation* is *connected*.

review means an examination of the specified matters conducted to the standard specified for a “review” in Auditing Standard (Specify the appropriate standard) by the Auditing Standards Board, as varied from time to time.

reviewable decision means a decision of the *Commission* that is specified as a reviewable decision (which, therefore, pursuant to the *Act*, can be reviewed by the High Court).

safety and operational area in respect of a powerline used for the *distribution* of electricity at a nominal *voltage* of not more than 88 kilovolts, means –

- (a) a strip of land of a width specified in the *Grid Code*; or

- (b) if the *Grid Code* does not so specify, a strip of land 12 metres wide defined by measuring 6 metres in a horizontal plane to each side of the centreline of a powerline at right angles to the centreline.

satisfactory operating state in relation to the *power system*, has the meaning given in clause 7.2.2.

scheduling interval means a 30 minute period ending on the hour (EAST) or on the half hour and, where identified by a *time*, means the 30 minute period ending at that *time*.

secondary equipment means those *assets* of a *Code Participant's facility* which do not carry the *energy* being traded, but which are required for control, protection or operation of *assets* which carry such *energy*.

secure operating state in relation to the *power system*, has the meaning given in clause 7.2.4.

Selected Network Service Provider means a *network service provider* to whom a *connection* enquiry has been made under clause 3.3.2(a).

self-dispatch means where the decision to *commit* and schedule a *generator* was made by the relevant *electric power producer*.

self-dispatch level means the level of *generation* in MW, as specified in the *dispatch information* for a *generator* and a *scheduling interval*, which is the level at which that *generator* shall be *dispatched* by the *System Operator* in that *scheduling interval* unless otherwise *dispatched* in accordance with clause 6.3.

sensitive loads are *loads* defined by the *Minister* and advised to the *System Operator* by the *Minister* in accordance with clause 7.3.3.

sent out, sent out generation in relation to an *electric power producer*, the amount of electricity supplied to the *transmission* or *distribution network* at his *connection point*.

service line means the terminating span of an *electric supply line*:-

- (a) constructed or designed or ordinarily used for the *supply* of electricity at *low voltage*; and
- (b) through which electricity is, or is intended to be, *supplied* by a *distribution network service provider* to a *point of supply*.

short term capacity reserve The amount of surplus or unused generating capacity indicated as being available for any half hour period at present or at any *time* until the end of the next 7 *days*, assessed as being in excess of the capacity requirement to meet the current forecast *load demand*, taking into account the known or historical levels of *demand* management.

short term capacity reserve standard means the level of *short term capacity reserve* required for a particular period in accordance with the *power system security and reliability standards*.

short term PASA means the *PASA* in respect of the period from 2 *days* after the current *day* to the end of the 7th *day* after the current *day* inclusive in respect of each *scheduling interval* in that period.

short term PASA inputs means the inputs to be prepared by the *System Operator* in accordance with clause 6.2.3(d).

series or shunt capacitor means a type of *plant connected to a network to generate reactive power.*

shunt reactor means a type of *plant connected to a network to absorb reactive power.*

single contingency in respect of a *transmission or distribution network and network users*, means a sequence of related events which result in the removal from service of one *network user, transmission or distribution line, or transformer.* The sequence of events may include the application and clearance of a fault of defined severity.

single credible contingency event means an event described in clause 7.2.3(c).

static excitation system means an *excitation control system* in which the power to the rotor of a *synchronous generator* is transmitted through high power solid-state electronic devices.

static VAR compensator, static reactive plant means a device or *plant* specifically provided on a *network* to provide the ability to generate and absorb *reactive power* and to respond automatically and rapidly to *voltage* fluctuations or *voltage* instability arising from a disturbance or disruption on the *transmission network.*

substation means a *facility* at which two or more *electric supply lines* are switched for operational purposes. It may include one or more *transformers* so that some *connected electric supply lines* operate at different nominal *voltages* to others.

supply means the delivery of electricity.

supply area has the same meaning ascribed to it as in the *Act.*

supply licence means a *licence* to sell electricity granted under the *Act.*

switchyard means the *connection point* of a *generator* into the *network*, generally involving the ability to *connect* the *generator* to one or more outgoing *network circuits.*

synchronise means the act of *synchronising* a *generator* to the *power system.*

synchronising, synchronisation means to electrically *connect* a *generator* to the *power system.*

synchronous condensers means *plant*, similar in construction to a *generator* of the *synchronous generator* category, which operates at the equivalent speed of the *frequency* of the *power system*, specifically provided to generate or absorb *reactive power* through the adjustment of rotor current.

synchronous generator voltage control means the automatic *voltage control system* of a *generator* of the *synchronous generator* category which *changes* the output *voltage* of the *generator* through the adjustment of the *generator* rotor current and effectively *changes* the *reactive power* output from that *generator.*

synchronous generator, means the alternating current *generators* of most thermal and hydro (water) driven power turbines which operate at the equivalent speed of the *frequency* of the *power system* in its *satisfactory operating state.*

System Operator means a person appointed in accordance with the *Act* to exercise system control over the *power system.*

System Planning and Reliability Council means the council established by the *Commission* to perform the tasks specified in clause 11.8.1.

take or pay contract means a contract between a buyer and a seller of an asset-based service under which the buyer undertakes to pay regularly to the seller a fixed or minimum sum, regardless of the actual level of consumption of the service by the buyer. The contract has the effect of transferring market risk associated with the *assets* from the seller (also the owner of the *assets*) to the buyer.

tap-changing transformer means a *transformer* with the capability to allow internal adjustment of output *voltages* which can be automatically or manually initiated and which is used as a major component in the control of the *voltage* of the *transmission* and *distribution networks* in conjunction with the operation of *reactive plant*. The *connection point* of a *generator* may have an associated tap-changing transformer, usually provided by the *electric power producer*.

tariff means the tariff required pursuant to section 62 of the *Act*.

technical envelope means the limits described in clause 7.2.5.

time means East African Standard Time.

timetable means the timetable determined by the *System Operator* and *published* for the purposes of the *dispatch* process.

transformer means a *plant* or device that reduces or increases the *voltage* of alternating current.

transformer tap position where a tap changer is fitted to a *transformer*, means each tap position represents a *change* in *voltage* ratio of the *transformer* which can be manually or automatically adjusted to change the *transformer* output *voltage*. The tap position is used as a reference for the output *voltage* of the *transformer*.

transitional provision means modification, variation or exemption to one or more provisions of the *Grid Code* in relation to a *Code Participant* according to clause 11.4.1(a) or Chapter 12.

transmission means activities pertaining to a *transmission network* including the conveyance of electricity.

transmission consumer means a *consumer* or *distribution network service provider* having a *connection point* with a *transmission network*.

transmission element means a single identifiable major component of a *transmission system* involving:

- (a) an individual *transmission* circuit or a phase of that circuit;
- (b) a major item of *transmission plant* necessary for the functioning of a particular *transmission* circuit or *connection point* (such as a *transformer* or a circuit breaker).

transmission line means a power line that is part of a *transmission network*.

transmission network has the meaning given in the *Act*.

transmission network owner means the owner of a *transmission network*.

transmission network service provider means a person who engages in the activity of owning, controlling, or operating a *transmission system*.

transmission network test means a test conducted to verify the magnitude of the *power transfer capability* of *interconnections* which comprise the *assets* of more than one *transmission network service provider* in accordance with clause 3.7.7.

transmission network user means a *transmission consumer*, an *electric power producer* whose *generator* is directly *connected* to the *transmission network* or a *network service provider* whose *network* is *connected* to the *transmission network*.

transmission or distribution system means a *transmission or distribution system* that:

- (1) is used to convey, and control the conveyance of, electricity to *consumers* (whether wholesale or retail); and
- (2) is *connected* to another such system.

transmission plant means apparatus or equipment associated with the function or operation of a *transmission line* or an associated *substation or switchyard*, which may include *transformers*, circuit breakers, *reactive plant* and *monitoring equipment* and control equipment.

transmission service means the services provided by a *transmission system* associated with the conveyance of electricity which include *entry services*, *transmission use of system services* and *exit services* and new *network services* which are being provided by part of a *transmission system*.

transmission system means a *transmission network* together with the *connection assets* associated with the *transmission network*, which is *connected* to another *transmission or distribution system*.

transmission use of system, transmission use of system service means a service provided to an *electric power producer* or *transmission consumer* for use of the *transmission network* for the conveyance of electricity that can be reasonably allocated to a *network user* on a locational basis.

unconstrained means free of *constraint*.

use of system includes *transmission use of system* and *distribution use of system*.

use of system services means *transmission use of system service* and *distribution use of system service*.

verifying authorities means authorities appointed by the Kenya Bureau of Standards Commission under the *National Measurements Act*.

violation in relation to *power system security*, means a failure to meet the requirements of Chapter 7 and the *power system security and reliability standards*.

voltage means the electronic force or electric potential between two points that gives rise to the flow of electricity, and for the purposes of Chapter 8 means (except in the case of *impulse voltage*) the root mean square (RMS) of the phase to phase *voltage*.

voltage transformer (VT) means a *transformer* for use with *meters* and/or protection devices in which the *voltage* across the secondary terminals is, within prescribed error limits, proportional to and in phase with the *voltage* across the primary terminals.

wayleave means a wayleave contract or a wayleave easement.

weighted average cost of capital means an amount determined in a manner consistent with schedule 5.1.

writing includes any mode of representing or reproducing words, figures, drawings or symbols in a visible form.

CHAPTER 3 NETWORK CONNECTION

TABLE OF CONTENTS

| | Page |
|--|------|
| 3.1 STATEMENT OF PURPOSE | 38 |
| 3.1.1 Application of Chapter 3 | 38 |
| 3.1.2 Purpose and aims | 38 |
| 3.1.3 Principles | 38 |
| 3.2 OBLIGATIONS | 39 |
| 3.2.1 Obligations of Code Participants | 39 |
| 3.2.2 Connection Agreements | 39 |
| 3.2.3 Obligations of network service providers | 39 |
| 3.2.4 Obligations of Consumers | 41 |
| 3.2.5 Obligations of electric power producers | 42 |
| 3.2.6 Review of technical standards for electric power producers | 43 |
| 3.3 ESTABLISHING OR MODIFYING CONNECTION | 43 |
| 3.3.1 Process and procedures | 43 |
| 3.3.2 Connection enquiry | 45 |
| 3.3.3 Response to connection enquiry | 45 |
| 3.3.4 Application for connection | 46 |
| 3.3.5 Preparation of Offer to Connect | 47 |
| 3.3.6 Offer to connect | 48 |
| 3.3.7 Finalisation of connection agreements | 49 |
| 3.3.8 Provision and use of information | 49 |
| 3.4 DESIGN OF CONNECTED EQUIPMENT | 50 |
| 3.4.1 Applicability | 50 |
| 3.4.2 Advice of inconsistencies | 50 |
| 3.4.3 Additional information | 50 |
| 3.4.4 Advice on possible non-compliance | 50 |
| 3.5 ACCESS ARRANGEMENTS FOR GENERATORS | 51 |
| 3.6 PLANNING AND DEVELOPMENT OF NETWORK | 52 |
| 3.6.1 Forecasts for connection points to transmission network | 52 |
| 3.6.2 Planning Statement | 52 |
| 3.6.3 Development of networks | 53 |
| 3.7 INSPECTION AND TESTING | 54 |
| 3.7.1 Right of entry and inspection | 54 |
| 3.7.2 Right of testing | 56 |

| | |
|---|----|
| 3.7.3 Tests to demonstrate compliance with connection requirements for Electric power producers | 57 |
| 3.7.4 Routine testing of protection equipment | 58 |
| 3.7.5 Testing by Code Participants of their own plant requiring changes to normal operation | 58 |
| 3.7.6 Tests of generators requiring changes to normal operation | 59 |
| 3.7.7 Power system tests | 60 |
| 3.8 COMMISSIONING | 61 |
| 3.8.1 Requirement to inspect and test equipment | 61 |
| 3.8.2 Co-ordination during commissioning | 61 |
| 3.8.3 Control and protection settings for equipment | 61 |
| 3.8.4 Commissioning program | 62 |
| 3.8.5 Commissioning tests | 62 |
| 3.9 DISCONNECTION AND RECONNECTION | 63 |
| 3.9.1 Voluntary disconnection | 63 |
| 3.9.2 Decommissioning procedures | 63 |
| 3.9.3 Involuntary disconnection | 63 |
| 3.9.4 Disconnection to implement Order of the Commission | 64 |
| 3.9.5 Disconnection during an emergency | 64 |
| 3.9.6 Obligation to reconnect | 64 |
| SCHEDULES TO CHAPTER 3 | 66 |

CHAPTER 3 NETWORK CONNECTION

3.1 STATEMENT OF PURPOSE

3.1.1 Application of Chapter 3

This Chapter 3 applies to:

- (a) *network service providers*;
- (b) the *System Operator*;
- (c) *consumers*;
- (d) *Electric power producers*; and
- (e) the *Commission*.

3.1.2 Purpose and aims

- (a) This Chapter of the *Grid Code*:
 - (1) provides the framework for *connection* to a *transmission network* or a *distribution network* and access to the *networks* forming the *Kenyan network*;
 - (2) provides for the development of *networks* as it is considered to require a degree of co-ordinated planning; and
 - (3) has the following aims:
 - (i) to detail the principles and guidelines governing *connection* and access to a *network* ;
 - (ii) to establish the process to be followed by a *Code Participant* to establish or modify a *connection* to a *network*;
 - (iii) to address the *connection applicant's* reasonable expectations of the level and standard of *power transfer capability* that the *network* should provide; and
 - (iv) to establish processes to ensure ongoing compliance with technical requirements of this Chapter 3 to facilitate management of the *Kenyan network*.
- (b) Any person who is not a *Code Participant* may agree with a *network service provider* to comply with this Chapter 3 as part of a *connection agreement*.
- (c) Nothing in the *Grid Code* is to be read or construed as preventing any person from constructing any *network* or *connection asset*.

3.1.3 Principles

Chapter 3 of the *Grid Code* is based on the following principles relating to *connection* to the *Kenyan network*:

- (a) All *Code Participants* should have the opportunity to form a *connection* to a *network* and have access to the *network services* provided by the *networks* forming the *Kenyan network*.
- (b) The terms and conditions on which *connection* to a *network* and provision of *network service* is to be granted are to be set out in a commercial agreement on reasonable terms entered into between a *network service provider* and other *Code Participants*.
- (c) Separate agreements may be required for *connection services* and *use of system services*.

- (d) The operation of the *Grid Code* should result in the achievement of:
- (1) long term benefits to *Code Participants* in terms of costs and reliability of the Kenyan *network*; and
 - (2) open communication and information flows between *Code Participants* relating to *connections* while ensuring the security of confidential information belonging to *Code Participants*.

3.2 OBLIGATIONS

3.2.1 Obligations of Code Participants

All *Code Participants* shall maintain and operate (or ensure their authorised representatives maintain and operate) all equipment that is part of their *facilities* in accordance with:

- (a) relevant Kenyan laws;
- (b) the requirements of the *Grid Code*; and
- (c) *good electricity industry practice* and applicable *Kenya Standards* or in their absence, equivalent international standards

3.2.2 Connection Agreements

- (a) This *Grid Code* applies to:
 - (1) all *connection agreements* made after the *commencement date*;
 - (2) all deemed *connection agreements* created pursuant to clause 3.2.2 (b); and
 - (3) all requests to establish *connection* or modify an existing *connection* after the *commencement date*.
- (b) *Network service providers* and the *network users* shall document the terms of any *network connection* arrangements made prior to the *commencement date* and the resulting documents will then be deemed to be *connection agreements* for the purposes of the *Grid Code*.
- (c) This Chapter 3 is neither intended to, nor is it to be read or construed as having the effect of:
 - (1) altering any of the terms of a *connection agreement*; or
 - (2) altering the contractual rights or obligations of any of the parties under the *connection agreement* as between those parties; or
 - (3) relieving the parties under any such *connection agreement* of their contractual obligations under such an agreement.
- (d) Notwithstanding the provisions of clause 3.2.2(c), if any obligation imposed or right conferred on a *Code Participant* by this Chapter 3 is inconsistent with the terms of a *connection agreement* to which the *Grid Code* applies and the application of the inconsistent terms of the *connection agreement* would adversely affect the quality or security of *network service* to other *network users*, the parties to the *connection agreement* shall observe the provisions of this Chapter 3 as if they prevail over the *connection agreement* to the extent of the inconsistency.

3.2.3 Obligations of Network Service Providers

- (a) A *network service provider* shall comply with the *power system* performance and quality of *supply* standards:
 - (1) described in schedule 3.1;

- (2) in accordance with any *connection agreement* with a *Code Participant*, and if there is an inconsistency between schedule 3.1 and such a *connection agreement*,
 - (3) if compliance with the relevant provision of the *connection agreement* would adversely affect the quality or security of *network service* to other *network users*, schedule 3.1 is to prevail;
 - (4) otherwise the *connection agreement* is to prevail.
- (b) Where the provisions of the *connection agreement* vary the technical requirements set out in the schedules to this Chapter 3, the relevant *network service provider* shall report on such variations to the *System Operator* on an annual basis. The *System Operator* shall allow access to such information to all other *network service providers* provided the *network service providers* and the *network service provider* shall keep such information confidential.
- (c) A *network service provider* shall:
- (1) receive and process applications to *connect* to his *network* or modification of a *connection* to his *network* which are submitted to him and shall enter into a *connection agreement* with each *Code Participant* and any other person to whom he has provided a *connection* to his *network* in accordance with clause 3.3 to the extent that the *connection point* relates to his part of the Kenyan *network*;
 - (2) ensure that to the extent that a *connection point* relates to his *network*, every arrangement for *connection* with a *Code Participant* or any other arrangement involving a *connection agreement* with that *network service provider* complies with all relevant provisions of the *Grid Code*;
 - (3) co-ordinate the design aspects of equipment proposed to be *connected* to his *network* with those of other *network service providers* in accordance with clause 3.4 in order to seek to achieve *power system* performance requirements in accordance with schedule 3.1;
 - (4) together with other *network service providers*, arrange for and participate in planning and development of their *networks* and *connection points* on or with those *networks* in accordance with clause 3.6;
 - (5) permit and participate in inspection and testing of *facilities* and equipment in accordance with clause 3.7;
 - (6) permit and participate in commissioning of *facilities* and equipment which is to be *connected* to his *network* in accordance with clause 3.8;
 - (7) advise a *Code Participant* or other person with whom there is a *connection agreement* upon request of any expected interruption characteristics at a *connection point* on or with his *network* so that the *Code Participant* or other person may make alternative arrangements for *supply* during such interruptions, including negotiating for an alternative or backup *connection*;
 - (8) use his reasonable endeavours to ensure that modelling data associated with the *assets* which comprise his *network* and used for planning, design and operational purposes is complete and accurate and order tests in accordance with clause 3.7 where there are reasonable grounds to question the validity of data;

- (9) provide to the *System Operator* and other *network service providers* all data available to him and reasonably required for modelling the static and dynamic performance of the *power system* which is to be undertaken by those persons;
 - (10) forward to the *System Operator* and other *network service providers* subsequent updates of the data referred to in clause 3.2.3(c)(9) and, to the best of his ability and knowledge, ensure that all data used for the purposes referred to in clause 3.3 is consistent with data used for such purposes by other *network service providers*;
 - (11) provide to the *System Operator* details of any *connection points* with other *network service providers*; and
 - (12) where *network reinforcements*, setting *changes* or other technical issues arise which could impact across regional boundaries, the relevant *network service provider* shall provide the *Commission* with a written report on the impact and their effects.
- (d) A *network service provider* shall arrange for:
- (1) operation of that part of the Kenyan *network* over which he has control in accordance with instructions given by the *System Operator*;
 - (2) management, maintenance and operation of his part of the Kenyan *network* such that in the satisfactory operating state, electricity may be transferred continuously at a *connection point* on or with his *networks* up to the *agreed capability*;
 - (3) operation of his *networks* such that the fault level at any *connection point* on or with that *network* does not exceed the limits that have been specified in a *connection agreement*;
 - (4) management, maintenance and operation of his *networks* to minimise the number of interruptions to *agreed capability* at a *connection point* on or with that *network* by using *good electricity industry practice*; and
 - (5) restoration of the *agreed capability* as soon as reasonably practicable following any interruption at a *connection point* on or with his *network*.
- (e) A *network service provider* shall comply with *applicable regulatory instruments* and all relevant provisions of the *Grid Code*.

3.2.4 Obligations of Consumers

- (a) Each *consumer* shall ensure that all *facilities* which are owned, operated or controlled by him and are associated with a *connection point* at all times comply with applicable requirements and conditions of *connection* for *consumers*:
- (1) as set out in schedule 3.3; and
 - (2) in accordance with any *connection agreement* with a *network service provider*, and if there is an inconsistency between schedule 3.3 and such a *connection agreement*,
 - (3) if compliance with the relevant provision of the *connection agreement* would adversely affect the quality or security of *network service* to other *network users*, schedule 3.3 is to prevail;
 - (4) otherwise, the *connection agreement* is to prevail.
- (b) A *consumer* shall:

- (1) submit an *application to connect* in respect of new or altered equipment owned, operated or controlled by the *consumer* and enter into a *connection agreement* with a *network service provider* in accordance with clause 3.3 prior to that equipment being *connected* to the *network* of that *network service provider* or altered (as the case may be);
- (2) comply with the reasonable requirements of the relevant *network service provider* in respect of design requirements of equipment proposed to be *connected* in accordance with clause 3.4 and schedule 3.3;
- (3) provide *load forecast* information to the *System Operator* and the relevant *network service provider* in accordance with clause 3.6;
- (4) permit and participate in inspection and testing of *facilities* and equipment in accordance with clause 3.7;
- (5) permit and participate in commissioning of *facilities* and equipment which is to be *connected* to a *network* for the first time in accordance with clause 3.8;
- (6) operate his *facilities* and equipment in accordance with any direction given by the *network service provider* and/or *System Operator*; and
- (7) give notice of any intended voluntary *disconnection* in accordance with clause 3.9.

3.2.5 Obligations of electric power producers

- (a) An *electric power producer* shall comply at all times with applicable requirements and conditions of *connection* for *generators*:
 - (1) as set out in schedule 3.2; and
 - (2) in accordance with any *connection agreement* with a *network service provider*, and if there is an inconsistency between schedule 3.2 and such a *connection agreement*:
 - (3) if compliance with the relevant provision of the *connection agreement* would adversely affect the quality or security of *network service* to other *network users*, schedule 3.2 is to prevail;
 - (4) otherwise, the *connection agreement* is to prevail.
- (b) Each *electric power producer* shall:
 - (1) submit an *application to connect* in respect of new or altered equipment owned, operated or controlled by him and enter into a *connection agreement* with a *network service provider* in accordance with clause 3.3 prior to that equipment being *connected* to the *network* of that *network service provider* or altered (as the case may be);
 - (2) comply with the reasonable requirements of the relevant *network service provider* in respect of design requirements of equipment proposed to be *connected* to the *network* of that *network service provider* in accordance with clause 3.4 and schedule 3.2;
 - (3) provide *generation forecast* information to the *System Operator* in accordance with clause 3.6;
 - (4) permit and participate in inspection and testing of *facilities* and equipment in accordance with clause 3.7;

- (5) permit and participate in commissioning of *facilities* and equipment which is to be *connected* to a *network* for the first time in accordance with clause 3.8;
- (6) operate *facilities* and equipment in accordance with any direction given by the *System Operator*; and
- (7) give notice of intended voluntary *disconnection* in accordance with clause 3.9.

3.2.6 Review of technical standards for electric power producers

Within 2 years of the *commencement date* the *Commission* shall undertake a review in accordance with the *Code consultation procedures* of and report on the technical standards to which *electric power producers* shall adhere pursuant to schedule 3.2.

The review shall consider:

- (a) whether these standards are too stringent to be met by persons seeking to develop *generation facilities*, or too lenient;
- (b) the relationship between these standards and the provision of *ancillary services*;
- (c) the need for consistency in adherence to technical standards by *electric power producers*; and
- (d) such other matters as the *Commission* considers appropriate.

3.3 ESTABLISHING OR MODIFYING CONNECTION

3.3.1 Process and procedures

- (a) The process and procedures to be followed by a *Code Participant* or which may be followed by any other person wishing to establish or modify *connection* to a *network* is shown in diagrammatic form under this clause 3.3.1.
- (b) Establishing *connection* in this clause includes modifying an existing *connection* to the Kenyan *network*.

Representation of the processes and procedures to establish or modify a connection

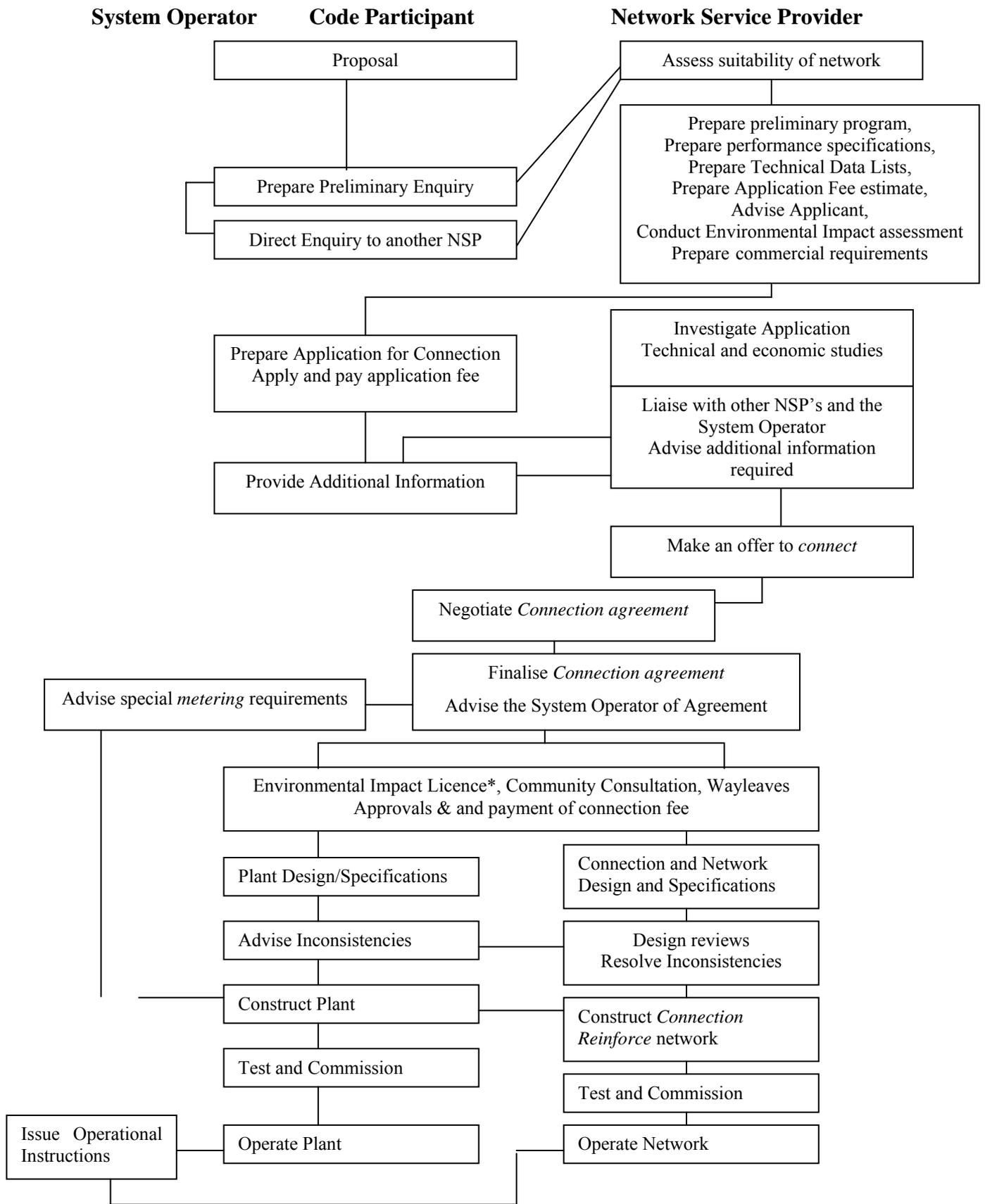

1

¹ *In accordance with the relevant laws of Kenya

3.3.2 Connection enquiry

- (a) An existing or intending *Code Participant* or a person, eligible to become a *Code Participant*, wishing to lodge or consider lodging an *application to connect* to a *network* shall first make a *connection enquiry* by advising a *network service provider* (“selected *network service provider*”) of the type, magnitude and timing of the proposed *connection* to the *network* of that selected *network service provider* and all other relevant preliminary information as listed in schedule 3.4.
- (b) The selected *network service provider* shall advise the *connection applicant* within 10 *business days* if the enquiry would be more appropriately directed to another *network service provider*. The *connection applicant*, notwithstanding the advice, may if it is reasonable in all the circumstances, request the selected *network service provider* to process the *connection enquiry* and the selected *network service provider* shall meet this request.
- (c) Where the selected *network service provider* considers that the *connection enquiry* should be jointly examined by more than one *network service provider*, with the agreement of the *connection applicant*, one of those *network service providers* may be allocated the task of liaising with the *connection applicant* and the other *network service providers* to process and respond to the enquiry.

3.3.3 Response to connection enquiry

- (a) In preparing a response to a *connection enquiry*, the *network service provider* shall liaise with other *network service providers* with whom he has *connection agreements*, if the *network service provider* believes, in his reasonable opinion, that the terms and conditions of those *connection agreements* will be affected. The *network service provider* responding to the *connection enquiry* may include in that response the reasonable requirements of any such other *network service providers* for information to be provided by the *connection applicant*.
- (b) The *network service provider* shall provide the following information in writing to the *connection applicant* within 2 weeks after receipt of the *connection enquiry* or, if the *connection applicant* requested the selected *network service provider* to process the *connection enquiry* under clause 3.3.2(b), within 2 weeks after receipt of that request:
 - (1) the identity of other parties that the *network service provider* considers:
 - (i) will need to be involved in planning to make the *connection*; and
 - (ii) shall be paid for *transmission* or *distribution service*;
 - (2) whether it will be necessary for any of the parties identified in clause 3.3.3(b)(1)(i) to enter into an agreement with the *connection applicant* in respect of the provision of *connection* or other *transmission services* or *distribution services* to the *connection applicant* or both;
 - (3) whether any service the *network service provider* proposes to provide is *contestable*;
 - (4) a preliminary program showing proposed milestones for *connection* and access activities which may be modified from time to time by agreement of the parties, which agreement shall not be unreasonably withheld.

Note: This is a generic representation of the major steps required to establish a connection. They may be varied to suit the circumstances of the application

- (c) If the *connection applicant* proceeds to lodge an *application to connect*, the *network service provider* shall provide to the *connection applicant* within 4 weeks after receipt of the *connection enquiry*, or if the *connection applicant* requested the selected *network service provider* to process the *connection enquiry* under clause 3.3.2(b), after receipt of that request, written advice of all further information which the *connection applicant* shall prepare and obtain in conjunction with the *network service provider* to enable the *network service provider* to assess an *application to connect* including:
- (1) details of the *connection requirements*, which shall be appropriate and comply with, unless varied by the *network service provider* depending on the *facility* to be *connected* and any special requirements at the *connection point*, the specifications set out in:
 - (i) schedule 3.1 for *connection of a network*;
 - (ii) schedule 3.2 for *connection of an electric power producer*;
 - (iii) schedule 3.3 for *connection of a consumer*;
 - (2) details of the *connection applicant's* reasonable expectations of the level and standard of service of *power transfer capability* that the *network* should provide;
 - (3) a list of the technical data to be included with the *application to connect* which may vary depending on the *connection requirements* and the type, rating and location of the *facility* to be *connected* and will generally be in the nature of the information set out in schedule 3.5 but may be varied by the *network service provider* as appropriate to suit the size and complexity of the proposed *facility* to be *connected*;
 - (4) commercial information to be supplied by the *connection applicant* to allow the *network service provider* to make an assessment of the ability of the *connection applicant* to satisfy the prudent requirements set out in clauses 5.3 and 5.6;
 - (5) the amount of the application fee which is payable on lodgement of an *application to connect*, such amount not being more than necessary to:
 - (i) cover the reasonable costs of all work anticipated to arise from investigating the *application to connect* and preparing the associated offer to *connect*; and
 - (ii) meet the reasonable costs anticipated to be incurred by other *network service providers* whose participation in the assessment of the *application to connect* will be required; and
 - (6) any other information relevant to the submission of an *application to connect*.

3.3.4 Application for connection

- (a) A person who has made a *connection enquiry* under clause 3.3.2, may following receipt of the responses under clause 3.3.3, make applications to *connect* in accordance with this clause.
- (b) To be eligible for *connection*, the *connection applicant* shall submit an *application to connect* containing the information specified in clause 3.3.3(c) and the relevant application fee to the relevant *network service provider*.
- (c) The *connection applicant* may submit applications to *connect* to more than one *network service provider* in order to receive additional offers to *connect* in respect of *facilities* to be provided that are *contestable*.

- (d) To the extent that an application fee includes amounts to meet the reasonable costs anticipated to be incurred by any other *network service providers* in the assessment of the *application to connect*, a *network service provider* who receives the *application to connect* and associated fee shall pay such amounts to the other *network service providers*.
- (e) Where designs or technical details submitted in the *application to connect* do not satisfy the requirements specified by the *network service provider* under clause 3.3.3(c), the *connection applicant* shall draw these to the attention of the *network service provider* in his *application to connect*.
- (f) The *connection applicant* may:
 - (1) lodge separate applications to *connect* and separately liaise with the other *network service providers* identified in clause 3.3.3(b) who may require a form of agreement; or
 - (2) lodge one *application to connect* with the *network service provider* who processed the *connection* enquiry and require him to liaise with those other *network service providers* and obtain and present all necessary draft agreements to the *connection applicant*.

3.3.5 Preparation of offer to connect

- (a) The *network service provider* to whom the *application to connect* is submitted in accordance with clause 3.3.4 shall proceed to prepare an offer to *connect* in response.
- (b) The *network service provider* shall use his reasonable endeavours to advise the *connection applicant* of all risks and obligations in respect of the proposed *connection* associated with planning and environmental laws not contained in the *Grid Code*.
- (c) The *connection applicant* shall provide such other additional information in relation to the *application to connect* as the *network service provider* reasonably requires to assess the technical performance and costs of the required *connection* and to enable the *network service provider* to prepare an offer to *connect*.
- (d) So as to maintain levels of service and quality of *supply* to existing *Code Participants* in accordance with the *Grid Code*, the *network service provider* in preparing the offer to *connect* shall consult with the *System Operator* and other *Code Participants* with whom he has *connection agreements*, if the *network service provider* believes, in his reasonable opinion, the terms and conditions of those *connection agreements* will be affected, in order to assess the *application to connect* and determine:
 - (1) the performance requirements for the equipment to be *connected*;
 - (2) the extent and cost of *reinforcement* and *changes* to all affected *networks*;
 - (3) any consequent *change* in *network service charges*; and
 - (4) the possible material effect of this new *connection* on the *network power transfer capability* including that of other *networks*.
- (e) If the *application to connect* indicates, or the *network service provider* has reasonable grounds to believe, that the *facility* proposed to be *connected* will cause distortion of the waveform, fluctuation in *voltage* or imbalance between the three phases of the *voltage* (in either magnitude or phase angle) at the *connection point* of another *Code Participant* the *network service provider* shall notify the *connection*

applicant of the reduced levels of such distorting effects that shall be achieved before *connection* can occur and provide to the *connection applicant* all information that is reasonably required to allow the *connection applicant* to design the *facility* to achieve these levels.

- (f) If the *application to connect* involves the *connection* of *generators* having a nameplate rating of 1.0 MW or greater to a *distribution network*, the *distribution network service provider* shall consult the relevant *transmission network service provider* regarding the impact of the *connection* contemplated by the *application to connect* on fault levels, line reclosure protocols, and stability aspects. The *transmission network service provider* shall determine the reasonable costs of addressing these matters for inclusion by the *network service provider* in the offer to *connect* and the *distribution network service provider* shall make it a condition of the offer to *connect* that the *connection applicant* pay these costs.
- (g) If the *application to connect* involves the *connection* of a *generator* or *facilities* which, when *connected*, would be a *generator*, the *network service provider* responsible for preparing the offer to *connect* shall consult the *System Operator*. The *network service provider* preparing the offer to *connect* shall include provision for payment of the reasonable costs associated with remote control equipment and remote monitoring equipment as required by the *System Operator* and it may be a condition of the offer to *connect* that the *connection applicant* pay such costs.

3.3.6 Offer to connect

- (a) The *network service provider* processing the *application to connect* shall make an offer to *connect* the *connection applicant's facilities* to the *network* within the time period specified in the preliminary program, unless otherwise agreed by the parties.
- (b) The offer to *connect* shall contain the proposed terms and conditions for *connection* to the *network* including, but not limited to, terms and conditions of the kind set out in schedule 3.6 and shall be capable of acceptance by the *connection applicant* so as to constitute a *connection agreement*.
- (c) The offer to *connect* shall be fair and reasonable and shall be consistent with the safe and reliable operation of the *power system* in accordance with the *Grid Code*. Without limitation, unless the parties otherwise agree, to be fair and reasonable an offer to *connect* shall offer *connection* and *network services* consistent with schedule 3.1 and (as applicable) schedules 3.2 and 3.3 and shall not impose conditions on the *connection applicant* which are more onerous than those contemplated in schedules 3.1, 3.2 or 3.3.
- (d) The *network service provider* shall use his reasonable endeavours to provide the *connection applicant* with an offer to *connect* in accordance with the reasonable requirements of the *connection applicant* including, without limitation, the location of the proposed *connection point* and the level and standard of *power transfer capability* that the *network* will provide.
- (e) The *network service provider* may offer terms and conditions which vary from those contemplated by the *Grid Code* where relevant considerations such as geographic factors make variation necessary or desirable provided that any such conditions are reasonable and are explicitly identified in the offer to *connect*.
- (f) An offer to *connect* may contain options for *connection* to a *network* at more than one point in a *network* and/or at different levels of service and with different terms and conditions applicable to each *connection point* according to the different characteristics of *supply* at each *connection point*.

- (g) Both the *network service provider* and the *connection applicant* are entitled to negotiate with each other in respect of the provision of *connection* and any other matters relevant to the provision of *connection* and, if negotiations occur, the *network service provider* and the *connection applicant* shall conduct such negotiations in good faith.
- (h) The offer to *connect* shall define the basis for determining *transmission* or *distribution service* charges in accordance with Chapter 5 of the *Grid Code* including the prudent requirements set out in clauses 5.3 and 5.6 as appropriate.
- (i) The offer to *connect* made to an *electric power producer* shall conform to the access arrangements for *electric power producers* set out in clause 3.3.
- (j) Nothing in the *Grid Code* is to be read or construed as imposing an obligation on a *network service provider* to effect an extension of a *network* unless that extension is required to effect or facilitate the *connection* of a *connection applicant* and the *connection* is the subject of a *connection agreement*.

3.3.7 Finalisation of connection agreements

- (a) If the *connection applicant* wishes to accept an offer to *connect*, the *connection applicant* shall:
 - (1) agree to be bound by relevant provisions of the *Grid Code*; and
 - (2) enter into a *connection agreement* with each relevant *network service provider* identified in accordance with clause 3.3.3(b)(2) and, in doing so, shall use his reasonable endeavours to negotiate in good faith with all parties with whom the *connection applicant* shall enter into such a *connection agreement*.
- (b) The provision of *connection* by any *network service provider* may be made subject to obtaining environmental and planning approvals for any necessary *reinforcement* or extension works to a *network*.
- (c) To the extent permitted by law, the *connection agreement* may assign responsibility to the *connection applicant* for obtaining the approvals referred to in clause 3.3.7(b) as part of the project proposal and the *network service provider* shall provide all reasonable information and may provide reasonable assistance for a reasonable fee to enable preparation of applications for such approvals.
- (d) Subject to clause 3.3.7(c), each *connection agreement* shall be based on the offer to *connect* as varied by agreement between the parties.
- (e) The *network service provider* responsible for the *connection point* and the *Code Participant* shall jointly advise the *System Operator* that a *connection agreement* has been entered into between them and forward to the *System Operator* relevant technical details of the proposed *plant* and *connection*, including the terms upon which a *Code Participant* is to *supply* any *ancillary services* under the *connection agreement*.

3.3.8 Provision and use of information

- (a) The data and information to be provided under this clause 3.3 shall be:
 - (1) prepared, given and used in good faith;
 - (2) treated as *confidential information*; and
 - (3) protected from being disclosed or made available by the recipient to a third party, except for the purpose of enabling *network service providers* and the *System Operator* to assess the effect of the proposed *facility* on the performance

of the *power system* and determine the extent of any required *reinforcement* or extension or advise the *System Operator* of *ancillary services* to be provided under a *connection agreement*.

- (b) A person intending to disclose information under 3.3.8(a)(3) shall first advise the relevant *connection applicant* of the extent of the disclosure.
- (c) If a *connection applicant* or *network service provider* becomes aware of any material change to any information contained in or relevant to an *application to connect* then he shall promptly notify the other party in writing of that *change*.

3.4 DESIGN OF CONNECTED EQUIPMENT

3.4.1 Applicability

This clause 3.4 applies only to new installations and modifications to existing installations after the *commencement date*.

3.4.2 Advice of inconsistencies

- (a) At any stage prior to commissioning the *facility* in respect of a *connection*, the *Code Participant* shall advise the *network service provider* in writing of any inconsistency between the proposed equipment and the provisions of the relevant *connection agreement* and, if necessary, the *network service provider* and the *Code Participant* shall negotiate in good faith any necessary *changes* to the *connection agreement*.
- (b) If there is an inconsistency in a *connection agreement* identified in clause 3.4.2(a), the *Code Participant* and *network service provider* shall not commission the *facility* in respect of a *connection* unless the *facility* or the *connection agreement* has been varied to remove the inconsistency

3.4.3 Additional information

A *Code Participant* shall provide any additional information in relation to his *plant* or associated equipment as the *network service provider* reasonably requests.

3.4.4 Advice on possible non-compliance

- (a) If the *network service provider* reasonably believes that the design of a proposed *facility* has potential to adversely and materially affect the performance of the *power system*, the *Code Participant* may be required to submit specified design information and drawings to the *network service provider* to enable the *network service provider* to assess the performance of the *facility* in respect of its interaction with the *power system*:
 - (1) after the *Code Participant* has entered into an agreement for supply of *plant* or associated equipment to be *connected*; and
 - (2) when the relevant contractor's designs have progressed to a point where preliminary designs are available but prior to manufacture of equipment.
- (b) The *network service provider* shall, within 40 *business days* of receipt of such information, use his reasonable endeavours to advise the *Code Participant* in writing of any design deficiencies which the *network service provider* believes would cause the design to be inconsistent with the *connection agreement* or the *Grid Code*.
- (c) Notwithstanding clause 3.4.4(b), it is the *Code Participant's* sole responsibility to ensure that all *plant* and equipment associated with the *connection* complies with the *connection agreement* and the *Grid Code*.

3.5 ACCESS ARRANGEMENTS FOR GENERATORS

- (a) The *network service provider* referred to under this clause 3.5 is the *network service provider* required under the *Grid Code* to process a *connection* enquiry or to submit an offer to *connect* for the provision of *network service* to the *electric power producer's generator* or group of *generators*.
- (b) If requested by an *electric power producer*, whether as part of a *connection* enquiry, *application to connect* or the subsequent negotiation of a *connection agreement*, the *network service provider* shall negotiate in good faith with the *electric power producer* to reach agreement in respect of the access arrangements sought by the *electric power producer*.
- (c) As a basis for negotiations under clause 3.5(b):
- (1) the *electric power producer* shall provide to the *network service provider* such information as is reasonably requested relating to the expected operation of his *generators*; and
 - (2) the *network service provider* shall provide to the *electric power producer* such information as is reasonably requested to allow the *electric power producer* to fully assess the commercial significance of the access arrangements sought by the *electric power producer* and offered by the *network service provider*.
- (d) An *electric power producer* may seek access arrangements at any level of *power transfer capability* between zero and the maximum power input of the *electric power producer's generators* or group of *generators*.
- (e) The *network service provider* shall use reasonable endeavours to provide the *electric power producer* access arrangements being sought subject to those arrangements being consistent with *good electricity industry practice* considering:
- (1) the *connection assets* to be provided by the *network service provider* or otherwise at the *connection point*; and
 - (2) the potential *reinforcements* or extensions required to be undertaken on all affected *transmission networks* or *distribution networks* to provide that level of *power transfer capability* over the period of the *connection agreement* taking into account the amount of *power transfer capability* provided to other *Code Participants* under *electric power producer* access arrangements in respect of all affected *transmission networks* and *distribution networks*.
- (f) The *network service provider* and the *electric power producer* shall negotiate in good faith to reach agreement as appropriate on the:
- (1) *connection service* charge to be paid by the *electric power producer* in relation to *connection assets* to be provided by the *network service provider*;
 - (2) *use of system services* charge to be paid by the *electric power producer* in relation to any *reinforcements* or extensions required to be undertaken in respect of all affected *transmission networks* and *distribution networks*; and
 - (3) amount to be paid by the *electric power producer* to the *network service provider* in relation to the costs reasonably incurred by the *network service provider* in providing access.
- (g) As at the *commencement date*, the maximum charge that can be applied by the *network service provider* in respect of *use of system services* for the *transmission network* and/or *distribution network* shall be determined in accordance with schedule 3.8.

- (h) The *Commission* shall undertake a review of the method by which *network service providers* are to determine the maximum prices to be paid by *electric power producers* for use of system, whether *transmission* or *distribution*.

3.6 PLANNING AND DEVELOPMENT OF NETWORK

3.6.1 Forecasts for connection points to transmission network

- (a) The *System Operator* shall give at least 40 *business days*' written notice to each relevant *Code Participant* of the annual date by which the *Code Participant* shall provide the *System Operator* with the short and long term electricity *generation* and *load forecast* information listed in schedule 3.7 in relation to each *connection point* which connects the *Code Participant* to the *transmission network* and any other relevant information as reasonably required by the *System Operator*.
- (b) Details of planned future *generators* and *loads* shall be given by each relevant *Code Participant* to the *System Operator* on reasonable request regarding the proposed commencing date, *active power capability* and *reactive power capability*, operating times/seasons and special operating requirements.
- (c) Each relevant *Code Participant* shall use reasonable endeavours to provide accurate information under clause 3.6.1(a) which shall include details of any factors which may impact on *load forecasts* or proposed *facilities* for *generation*.
- (d) If the *System Operator* reasonably believes any forecast information to be inaccurate, the *System Operator* may modify that forecast information and shall advise the relevant *Code Participants* in writing of this action and the reason for the modification provided that the *System Operator* is not responsible for any adverse consequences of this action or for failing to modify forecast information under this clause 3.6.1(d).

3.6.2 Planning Statement

By 31 December each year the *System Operator* shall:

- (a) consider the following matters:
- (1) the most recent forecasts provided under clause 3.6.1;
 - (2) the most recent annual planning review conducted under clause 3.6.3(b);
 - (3) possible scenarios for *load* growth covering average expectations and lower and upper bounds;
 - (4) possible scenarios for additional *generation*, *energy storage facilities* or *demand side* options needed to meet that *load*;
 - (5) committed projects for additional *generation*, *demand side* or *energy storage facilities*, or *reinforcement* of any *transmission network*;
 - (6) applications to *connect* or finalised *connection agreements* relating to the establishment of new interconnectors;
 - (7) an identification of the magnitude and significance of future *network losses* and *constraints* on *power transfers*;
 - (8) the periodic review of options developed by the *transmission network service provider* under clause 3.6.3 for the removal or reduction of each *network constraint* as soon as practicable based on the most recent assessment of *reinforcement* options;

- (9) any *transmission system reinforcement* proposals submitted by the *transmission network service provider*; and
- (b) produce and publish a planning statement concerning:
 - (1) the performance of the existing *transmission system* and generating systems;
 - (2) *power transfer capabilities* within the *transmission network* and through interconnectors proposed under clause 3.6.2(a)(6);
 - (3) the adequacy of the *transmission system* and available generating systems to meet the forecast *power transfers* and *forecast load* over a period of 15 years from 1 January in the year following the date on which the planning statement is prepared using the most recent forecasts under clause 3.6.1;
 - (4) the existence of *transmission constraints*; and
 - (5) the adequacy of *ancillary services* to meet the forecast *power transfers* and *forecast load* over a period of 10 years from 1 January in the year following the date on which the planning statement is prepared using the most recent forecasts under clause 3.6.1.

3.6.3 Development of networks

- (a) The *transmission network service provider* and the *distribution network service provider* shall analyse the expected future operation of their *transmission network* or *distribution network*, as the case may be, over an appropriate planning period, taking into account the relevant forecast *loads*, any future *generation* and *transmission* developments, the most recent planning statement and any other relevant data.
- (b) The *transmission network service provider* shall conduct an annual planning review with the *distribution network service provider* connected to the *transmission network*. The annual planning review shall take account of the most recent planning statement and incorporate the forecast *loads* submitted by the *distribution network service provider* in accordance with clause 3.6.1 or as modified in accordance with clause 3.6.1(d) and shall include a review of the adequacy of existing *connection points* and relevant parts of the *transmission system* and planning proposals for future *connection points*.
- (c) The annual planning review is to comprise a planning period of 5 years for *distribution networks* and 20 years for *transmission networks*.
- (d) *network service providers* may extrapolate the forecasts provided by *Code Participants* and/or the *System Operator* for the purpose of the annual planning review and where this analysis indicates that any relevant technical limits of the *transmission system* and the *distribution system* will be exceeded, either in normal conditions or following the contingencies specified in schedule 3.1, the *network service provider* shall notify any affected *Code Participants* of these limitations and advise those *Code Participants* of the expected time required to allow appropriate corrective *reinforcement* of the *network* or modifications to *connection facilities* to be undertaken.
- (e) Within the time for corrective action notified in clause 3.6.3(d) the *network service provider* shall consult with affected *Code Participants*, the *System Operator* and interested parties on the possible options including, but not limited to, *reinforcement*, *demand side* and *generation* options to address the projected limitations of the relevant *transmission system* or *distribution system*.

- (f) *network service providers* shall carry out an economic cost effectiveness analysis of possible options to identify options that satisfy the regulatory test, while meeting the technical requirements of schedule 3.1 of the *Grid Code*.
- (g) Following the consultations with the affected *Code Participants* and the *System Operator*, the *network service provider* shall prepare a report that is to be made available to affected *Code Participants*, the *System Operator*, the *System Planning and Reliability Council*, the *Commission* and interested parties which:
 - (1) includes an assessment of all identified options;
 - (2) includes details of the *network service provider*'s preferred proposal;
 - (3) summarises the submissions from the consultations; and
 - (4) recommends the action to be taken.
- (h) If the *Commission* determines, having regard to the report prepared by the *network service provider* under clause 3.6.3(g), that a *reinforcement* of a *network* is justified, then the *network service provider* whose *networks* would require *reinforcement* may arrange for the *reinforcement* project to be undertaken. In the absence of any such determination, the *network service provider* whose *networks* would require *reinforcement* may nonetheless arrange for the *reinforcement* project to be undertaken.
- (i) If a *use of system service* or the provision of a service at a *connection point* is directly affected by a *reinforcement*, appropriate amendments to relevant *connection agreements* shall be negotiated in good faith between the parties to them.
- (j) Where the *network service provider* decides to implement a *generation* option as an alternative to *network reinforcement*, the *network service provider* shall:
 - (1) specify to the *System Operator* that the *generator* may be periodically used to provide a *network* support function; and
 - (2) include the cost of this *network* support service in the calculation of *transmission service* and *distribution service* prices determined in accordance with Chapter 5 of the *Grid Code*.
- (k) The *Commission* shall:
 - (1) establish the regulatory test by issuing a guideline (and may vary the regulatory test from time to time); and
 - (2) have regard to the need to ensure the regulatory test is consistent with the basis of *asset* valuation as provided for in Chapter 5.
- (l) Prior to establishing or varying the regulatory test the *Commission* shall consult with affected *Code Participants* and other interested parties.

3.7 INSPECTION AND TESTING

3.7.1 Right of entry and inspection

- (a) If a *Code Participant* who is party to a *connection agreement* reasonably believes that the other party to the *connection agreement* is not complying with a technical provision of the *Grid Code* and that, as a consequence, the *Code Participant* is suffering, or is likely to suffer, a material adverse effect, then the first *Code Participant* may enter the relevant *facility* at the *connection point* of the other *Code Participant* in order to assess compliance by the relevant *Code Participant* with his technical obligations under the *Grid Code*.

- (b) A *Code Participant* who wishes to inspect the *facilities* of another *Code Participant* under clause 3.7.1(a) shall give that other *Code Participant* at least 2 *business days*' notice of his intention to carry out an inspection.
- (c) A notice given under clause 3.7.1(b) shall include the following information:
 - (1) the name of the representative who will be conducting the inspection on behalf of the *Code Participant*;
 - (2) the time when the inspection will commence and the expected time when the inspection will conclude; and
 - (3) the nature of the suspected non-compliance with the *Grid Code*.
- (d) A *Code Participant* may not carry out an inspection under this clause 3.7 within 6 months of any previous inspection except for the purpose of verifying the performance of corrective action claimed to have been carried out in respect of a non-conformance observed and documented on the previous inspection or for the purpose of investigating an operating incident in accordance with clause 7.8.16.
- (e) At any time when the representative of a *Code Participant* is in another *Code Participant's facility*, that representative shall:
 - (1) cause no damage to the *facility*;
 - (2) only interfere with the operation of the *facility* to the extent reasonably necessary and approved by the relevant *Code Participant* (such approval not to be unreasonably withheld or delayed); and
 - (3) observe "permit to test" access to sites and clearance protocols of the operator of the *facility*, provided that these are not used by the operator of the *facility* solely to delay the granting of access to site and inspection.
- (f) Any representative of a *Code Participant* conducting an inspection under this clause 3.7.1 shall be appropriately qualified to perform the relevant inspection.
- (g) The costs of inspections under this clause 3.7.1 shall be borne by the *Code Participant* requesting the inspection.
- (h) The *Commission* and the *System Operator* or any of their representatives (including authorised *agents*) may, in accordance with this clause 3.7, inspect a *facility* of a *Code Participant* and the operation and maintenance of that *facility* in order to:
 - (1) assess compliance by the relevant *Code Participant* with his operational obligations under Chapter 7, or an *ancillary services agreement*;
 - (2) investigate any possible past or potential threat to *power system security*; or
 - (3) conduct any periodic familiarisation or training associated with the operational requirements of the *facility*.
- (i) Any inspection under clause 3.7.1(a) or (h) shall only be for so long as is reasonably necessary.
- (j) Any equipment or goods installed or left on land or in premises of a *Code Participant* after an inspection conducted under this clause 3.7.1 do not become the property of the relevant *Code Participant* (notwithstanding that they may be annexed or affixed to the relevant land or premises).
- (k) In respect of any equipment or goods left on land or premises of a *Code Participant* during or after an inspection, a *Code Participant*:

- (1) shall not use any such equipment or goods for a purpose other than as contemplated in the *Grid Code* without the prior written approval of the owner of the equipment or goods;
 - (2) shall allow the owner of any such equipment or goods to remove any such equipment or goods in whole or in part at a time agreed with the relevant *Code Participant* such agreement not to be unreasonably withheld or delayed; and
 - (3) shall not create or cause to be created any mortgage, charge or lien over any such equipment or goods.
- (l) A *Code Participant* (in the case of an inspection carried out under clause 3.7.1(a)) or the *System Operator* (in the case of an inspection carried out under clause 3.7.1(h)) shall provide the results of that inspection to the *Code Participant* whose facilities have been inspected, and any other *Code Participant* who is likely to be materially affected by the results of the test or inspection and the *System Operator* (in the case of an inspection carried out under clause 3.7.1.(a)).

3.7.2 Right of testing

- (a) A *Code Participant* who has reasonable grounds to believe that equipment owned or operated by a *Code Participant* with whom he has a *connection agreement* (which equipment is associated with the *connection agreement*) may not comply with the *Grid Code* or the *connection agreement* may require testing of the relevant equipment by giving notice in writing to the other *Code Participant*.
- (b) If a notice is given under clause 3.7.2(a) the relevant test is to be conducted at a time agreed by the *System Operator*.
- (c) The *Code Participant* who receives a notice under clause 3.7.2(a) shall co-operate in relation to conducting tests requested under clause 3.7.2(a).
- (d) The cost of tests requested under clause 3.7.2(a) shall be borne by the *Code Participant* requesting the test, unless the equipment is determined by the tests not to comply with the relevant *connection agreement* and the *Grid Code*, in which case all reasonable costs of such tests shall be borne by the owner of that equipment.
- (e) Tests conducted in respect of a *connection point* under this clause 3.7.2 shall be conducted using test procedures agreed between the relevant *Code Participants*, which agreement is not to be unreasonably withheld or delayed.
- (f) Tests under this clause 3.7.2 shall be conducted only by persons with the relevant skills and experience.
- (g) A *transmission network service provider* shall give the *System Operator* adequate prior notice of intention to conduct a test in respect of a *connection point* to that *network service provider's network*.
- (h) The *Code Participant* who requests a test under this clause 3.7.2 may appoint a representative to witness a test and the relevant *Code Participant* shall permit a representative appointed under this clause 3.7.2(h) to be present while the test is being conducted.
- (i) A *Code Participant* who conducts a test shall submit a report to the *Code Participant* who requested the relevant test, the *System Operator* and to any other *Code Participant* who is likely to be materially affected by the results of the test within a reasonable period after the completion of the test and the report is to outline relevant details of the tests conducted including, but not limited to, the results of those tests.

- (j) A *network service provider* may attach test equipment or monitoring equipment to *plant* owned by a *Code Participant* or require a *Code Participant* to attach such test equipment or monitoring equipment, subject to the provisions of clause 3.7.1 regarding entry and inspection.
- (k) In carrying out monitoring under clause 3.7.2(j) the *network service provider* shall not cause the performance of the monitored *plant* to be *constrained* in any way.

3.7.3 Tests to demonstrate compliance with connection requirements for electric power producers

- (a) Each *electric power producer* shall provide evidence to any relevant *network service provider* with which that *electric power producer* has a *connection agreement* and the *System Operator* that each of his *generators* complies with the technical requirements of clause S3.2.5 of schedule 3.2 and the relevant *connection agreement*.
- (b) Each *electric power producer* shall negotiate in good faith with the relevant *network service provider* and the *System Operator* to agree on a compliance monitoring program, including an agreed method, for each of his *generators* to confirm ongoing compliance with the applicable technical requirements of clause S3.2.5 of schedule 3.2 and the relevant *connection agreement*.
- (c) If a performance test or monitoring of in-service performance demonstrates that a *generator* is not complying with one or more technical requirements of clause S3.2.5 of schedule 3.2 and the relevant *connection agreement* then the *electric power producer* shall:
 - (1) promptly notify the relevant *network service provider* and the *System Operator* of that fact;
 - (2) promptly advise the *network service provider* and the *System Operator* of the remedial steps he proposes to take and the timetable for such remedial work;
 - (3) diligently undertake such remedial work and report at monthly intervals to the *network service provider* and the *System Operator* on progress in implementing the remedial action; and
 - (4) conduct further tests or monitoring on completion of the remedial work to confirm compliance with the relevant technical requirement.
- (d) If a relevant *network service provider* or the *System Operator* reasonably believes that a *generator* is not complying with one or more technical requirements of clause S3.2.5 of schedule 3.2 and the relevant *connection agreement*, that *network service provider* or the *System Operator* may instruct the *electric power producer* to conduct tests within 25 *business days* to demonstrate that the relevant *generator* complies with those technical requirements and if the tests provide evidence that the relevant *generator* continues to comply with the technical requirement(s) the *network service provider* or the *System Operator* (as appropriate) shall reimburse the *electric power producer* for the reasonable expenses incurred as a direct result of conducting the tests.
- (e) If the *System Operator* or a *network service provider*:
 - (1) is satisfied that a *generator* does not comply with one or more technical requirements;
 - (2) does not have evidence demonstrating that a *generator* complies with the technical requirements set out in clause S3.2.5 of schedule 3.2; and

(3) holds the reasonable opinion that there is or could be a threat to the *power system security*,

the *System Operator* or a *network service provider* (as the case may be) may, independently or on the advice of the other, direct the relevant *electric power producer* to operate the relevant *generator* at a particular generated output or in a particular mode until the relevant *electric power producer* submits evidence reasonably satisfactory to the *network service provider* that the *generator* is complying with the relevant technical requirement.

(f) Each *electric power producer* shall maintain records for 7 years for each of his *generators* and power stations setting out details of the results of all technical performance and monitoring conducted under this clause 3.7.3 and make these records available to the relevant *network service provider* or the *System Operator* on request.

3.7.4 Routine testing of protection equipment

(a) A *Code Participant* shall cooperate with any relevant *network service provider* to test the operation of equipment forming part of a protection system relating to a *connection point* at which that *Code Participant* is *connected* to a *network* and the *Code Participant* shall conduct these tests:

- (1) prior to the *plant* at the relevant *connection point* being placed in service; and
- (2) at intervals specified in the *connection agreement* or in accordance with an *asset management plan* agreed between the *network service provider* and the *Code Participant*.

(b) Each *Code Participant* is to bear his own costs of conducting tests under this clause 3.7.4.

3.7.5 Testing by Code Participants of their own plant requiring changes to normal operation

(a) A *Code Participant* proposing to conduct a test on equipment related to a *connection point*, which requires a *change* to the normal operation of that equipment, shall give notice in writing to the relevant *network service provider* of at least 15 *business days* except in an emergency.

(b) The notice to be provided under clause 3.7.5(a) is to include:

- (1) the nature of the proposed test;
- (2) the estimated start and finish time for the proposed test;
- (3) the identity of the equipment to be tested;
- (4) the *power system* conditions required for the conduct of the proposed test;
- (5) details of any potential adverse consequences of the proposed test on the equipment to be tested;
- (6) details of any potential adverse consequences of the proposed test on the *power system*; and
- (7) the name of the person responsible for the coordination of the proposed test on behalf of the *Code Participant*.

(c) The *network service provider* shall review the proposed test to determine whether the test:

- (1) could adversely affect the normal operation of the *power system*;

- (2) could cause a threat to *power system security*;
 - (3) requires the *power system* to be operated in a particular way which differs from the way in which the *power system* is normally operated; or
 - (4) could affect the normal *metering of energy* at a *connection point*.
- (d) If the *network service provider* determines that the proposed test does fulfil one of the conditions specified in clause 3.7.5(c), then the *Code Participant* and *network service provider* shall seek the *System Operator*'s approval prior to undertaking the test, which approval shall not be unreasonably withheld or delayed.
 - (e) If, in the *System Operator*'s reasonable opinion, a test could threaten public safety, damage or threaten to damage equipment or adversely affect the operation of the *power system*, the *System Operator* may direct that the proposed test procedure be modified or that the test not be conducted at the time proposed.
 - (f) The *System Operator* shall advise any other *Code Participants* who might be adversely affected by a proposed test and consider any reasonable requirements of those *Code Participants* when approving the proposed test.
 - (g) The *Code Participant* who conducts a test under this clause 3.7.5 shall ensure that the person responsible for the coordination of a test promptly advises the *System Operator* when the test is complete.
 - (h) If the *System Operator* approves a proposed test, the *System Operator* shall use his reasonable endeavours to ensure that *power system* conditions reasonably required for that test are provided as close as is reasonably practicable to the proposed start time of the test and continue for the proposed duration of the test.
 - (i) Within a reasonable period after any such test has been conducted, the *Code Participant* who has conducted a test under this clause 3.7.5 shall provide the *network service provider* with a report in relation to that test including test results where appropriate.

3.7.6 Tests of generators requiring changes to normal operation

- (a) The *network service provider* may, at intervals of not less than 12 months per *generator*, require the testing by an *electric power producer* of any *generator connected* to the *network* of that *network service provider* in order to determine analytic parameters for modelling purposes or to assess the performance of the relevant *generator* and the *network service provider* is entitled to witness such tests.
- (b) Adequate notice of not less than 15 *business days* shall be given by the *network service provider* to the *electric power producer* before the proposed date of a test under clause 3.7.6(a).
- (c) The *network service provider* shall use his best endeavours to ensure that tests permitted under this clause 3.7.6 are conducted at a time which will minimise the departure from the *commitment* and *dispatch* that are due to take place at that time.
- (d) If not possible beforehand, an *electric power producer* shall conduct a test under this clause 3.7.6 at the next scheduled outage of the relevant *generator* and in any event within 9 months of the request.
- (e) An *electric power producer* shall provide any reasonable assistance requested by the *network service provider* in relation to the conduct of tests.
- (f) Tests conducted under this clause 3.7.6 shall be conducted in accordance with test procedures agreed between the *network service provider*, the *System Operator* and the relevant *electric power producer* and an *electric power producer* shall not

unreasonably withhold his agreement to test procedures proposed for this purpose by the *network service provider*.

- (g) The *network service provider* shall provide to an *electric power producer* and the *System Operator* such details of the analytic parameters of the model derived from the tests referred to in this clause 3.7.6 for any of that *electric power producer's generators* as may reasonably be requested.
- (h) Each *electric power producer* shall bear his own costs associated with tests conducted under this clause 3.7.6 and no compensation is to be payable for financial losses incurred as a result of these tests or associated activities.

3.7.7 Power system tests

- (a) Tests conducted for the purpose of verifying the magnitude of the *power transfer capability* of *transmission networks* which comprise the *assets* of more than one *transmission network service provider*, shall be coordinated by the *System Operator* and all associated *transmission network service providers*.
- (b) The tests described in clause 3.7.7(a) may be conducted whenever:
 - (1) a new *transmission line* is commissioned;
 - (2) an existing *transmission line* is *reinforced* or substantially modified;
 - (3) a new *generator* or *facility* of a *consumer* or a *network* development is commissioned that is calculated or anticipated to substantially alter *power transfer capability* through the *transmission lines*;
 - (4) setting *changes* are made to any *power system* stabilisers; or
 - (5) a test is required to verify the performance of the *power system*.
- (c) If the *System Operator* or a *network service provider* wishes or is required to conduct a test under this clause 3.7.7, he shall provide notice in writing to all relevant *Code Participants* at least 40 *business days* prior to the proposed test.
- (d) The *System Operator* shall develop a program and coordination arrangements for the tests which are to include criteria for continuation with the tests and operational procedures.
- (e) The approval in principle of all *transmission network service providers* whose *networks* could reasonably be expected to be materially affected by the test proposed under this clause 3.7.7 and all *Code Participants* who could reasonably be expected to be affected by the proposed test is required at least 15 *business days* before any test under this clause 3.7.7 may proceed.
- (f) Operational conditions for each test shall be arranged by the *System Operator* and the test procedures shall be coordinated by an officer nominated by the *System Operator* who has authority to stop the test or any part of it or vary the procedure within pre-approved guidelines if that officer considers any of these actions to be reasonably necessary.
- (g) Each *Code Participant* shall cooperate with the *network service provider(s)* and the *System Operator* when required in planning, preparing for and conducting *transmission network tests* to assess the technical performance of the *transmission networks* and if necessary conduct co-ordinated activities to prepare for *power system* wide testing or individual, on-site tests of the *Code Participant's facilities* or *plant*, including *disconnection* of a *generator*.

- (h) The *System Operator* may direct operation of *generators* by *electric power producers* during *power system* tests if this is necessary to achieve operational conditions on the *transmission networks* which are reasonably required to achieve valid test results.
- (i) The *System Operator* shall plan the timing of tests so that the variation from *dispatch* that would otherwise occur is minimised and the duration of the tests is as short as possible consistent with test requirements and *power system security*.

3.8 COMMISSIONING

3.8.1 Requirement to inspect and test equipment

- (a) A *Code Participant* shall ensure that any of his new or replacement equipment is inspected and tested to demonstrate that it complies with the relevant *Kenya Standards* or other acceptable standard, the *Grid Code* and any relevant *connection agreement* prior to or within an agreed time after being *connected* to a *transmission network* or *distribution network*, and the relevant *network service provider* is entitled to witness such inspections and tests.
- (b) The *Code Participant* shall produce test certificates on *demand* by the relevant *network service provider* showing that the equipment has passed the tests and complies with the standards set out in clause 3.8.1(a) before *connection* to a *network*, or within an agreed time thereafter.

3.8.2 Co-ordination during commissioning

A *Code Participant* seeking to *connect* to a *network* shall cooperate with the relevant *network service provider(s)* and the *System Operator* to develop procedures to ensure that the commissioning of the *connection* and *connected facility* is carried out in a manner that:

- (a) does not adversely affect other *Code Participants* or affect *power system security* or quality of *supply* of the *power system*; and
- (b) minimises the threat of damage to any other *Code Participant's* equipment.

3.8.3 Control and protection settings for equipment

- (a) Not less than 3 months prior to the proposed commencement of commissioning of any new or replacement equipment that could reasonably be expected to alter performance of the *power system*, (other than replacement by identical equipment), the *Code Participant* shall submit to the *network service provider* sufficient design information including proposed parameter settings to allow critical assessment including analytical modelling of the effect of the new or replacement equipment on the performance of the *power system*
- (b) The *network service provider* shall:
 - (1) consult with other *Code Participants* and the *System Operator* as appropriate; and
 - (2) within 20 *business days* of receipt of the design information under clause 3.8.3(a), notify the *Code Participant* of any comments on the proposed parameter settings for the new or replacement equipment.
- (c) If the *network service provider's* comments include alternative parameter settings for the new or replacement equipment, then the *Code Participant* shall notify the *network service provider* that he either accepts or disagrees with the alternative parameter settings suggested by the *network service provider*.

- (d) The *network service provider* and *Code Participant* shall negotiate parameter settings that are acceptable to them both and if there is any unresolved disagreement between them, the matter shall be determined in accordance with the dispute resolution procedure in clause 11.2.
- (e) The *Code Participant* and the relevant *network service provider* shall co-operate with each other to ensure that adequate grading of protection is achieved so that faults within the *Code Participant's facility* are cleared without adverse effects on the *power system*.

3.8.4 Commissioning program

- (a) Prior to the proposed commencement of commissioning by a *Code Participant* of any new or replacement equipment that could reasonably be expected to alter performance of the *power system*, the *Code Participant* shall advise the relevant *network service provider* and the *System Operator* in writing of the commissioning program including test procedures and proposed test equipment to be used in the commissioning.
- (b) Notice under clause 3.8.4(a) shall be given not less than three months prior to commencement of commissioning for a *connection* to a *transmission network*, or not less than one month prior to commencement of commissioning for a *connection* to a *distribution network*.
- (c) The relevant *network service provider* and the *System Operator* shall, within 15 *business days* of receipt of such advice under clause 3.8.4(a), notify the *Code Participant* either that they:
 - (1) agree with the proposed commissioning program and test procedures; or
 - (2) require *changes* in the interest of maintaining *power system security*, safety or quality of *supply*.
- (d) If the relevant *network service provider* or the *System Operator* require *changes*, then the parties shall co-operate to reach agreement and finalise the commissioning program within a reasonable period.
- (e) A *Code Participant* shall not commence the commissioning until the commissioning program has been finalised and the relevant *network service provider* and the *System Operator* shall not unreasonably delay finalising a commissioning program.

3.8.5 Commissioning tests

- (a) The relevant *network service provider* and/or the *System Operator* has the right to witness commissioning tests relating to new or replacement equipment that could reasonably be expected to alter performance of the *power system* or the accurate *metering* of *energy*.
- (b) The relevant *network service provider* and the *System Operator* shall, within a reasonable period of receiving advice of commissioning tests, notify the *Code Participant* whose new or replacement equipment is to be tested under this clause 3.8.5 whether or not it:
 - (1) wishes to witness the commissioning tests; and
 - (2) agrees with the proposed commissioning times.
- (c) A *Code Participant* whose new or replacement equipment is tested under this clause 3.8.5 shall submit to the relevant *network service provider* and the *System Operator* the commissioning test results demonstrating that a new or replacement item of equipment complies with the *Grid Code* or the relevant *connection agreement* or

both to the satisfaction of the relevant *network service provider* and the *System Operator*.

- (d) If the commissioning tests conducted in relation to a new or replacement item of equipment demonstrates non-compliance with one or more requirements of the *Grid Code* or the relevant *connection agreement* then the *Code Participant* whose new or replacement equipment was tested under this clause 3.8.5 shall promptly meet with the *network service provider* and the *System Operator* to agree on a process aimed at achievement of compliance of the relevant item with the *Grid Code*.
- (e) The *System Operator* may independently or on the request by a *network service provider* direct that the commissioning and subsequent *connection* of the *Code Participant's* equipment shall not proceed if the relevant equipment does not meet the technical requirements specified in clause 3.8.1.

3.9 DISCONNECTION AND RECONNECTION

3.9.1 Voluntary disconnection

- (a) Unless agreed otherwise and specified in a *connection agreement*, a *Code Participant* shall give to the relevant *network service provider* notice in writing of his intention to permanently *disconnect a facility* from a *connection point*.
- (b) A *Code Participant* is entitled, subject to the terms of the relevant *connection agreement*, to require voluntary permanent *disconnection* of his equipment from a *network* in which case appropriate operating procedures necessary to ensure that the *disconnection* will not threaten *power system security* shall be implemented in accordance with clause 3.9.2.
- (c) The *Code Participant* shall pay all costs directly attributable to the voluntary *disconnection* and *decommissioning*.

3.9.2 Decommissioning procedures

- (a) In the event that a *Code Participant's facility* is to be permanently *disconnected* from a *network*, whether in accordance with clause 3.9.1 or otherwise, the *network service provider* and *Code Participant* shall, prior to such *disconnection* occurring, follow agreed procedures for *disconnection*.
- (b) The *network service provider* shall notify the *System Operator* and any other *Code Participants* with whom he has a *connection agreement* if he believes, in his reasonable opinion, the terms and conditions of such a *connection agreement* will be affected by procedures for *disconnection* or proposed procedures agreed with any other *Code Participant*. The parties shall negotiate any amendments to the procedures for *disconnection* or the *connection agreement* that may be required.
- (c) Any *disconnection* procedures agreed to or determined under clause 3.9.2(a) shall be followed by all relevant *network service providers* and *Code Participants*.

3.9.3 Involuntary disconnection

- (a) The *System Operator* or a *network service provider* may *disconnect* a *Code Participant's facilities* from a *network*:
 - (1) pursuant to an order of the *Commission* in accordance with clause 3.9.4;
 - (2) during an emergency in accordance with clause 3.9.5;
 - (3) in accordance with applicable laws; or
 - (4) in accordance with the provisions of the *Code Participant's connection agreement*.

- (b) In all cases of *disconnection* by the *System Operator* during an emergency in accordance with clause 3.9.5, the *System Operator* is required to undertake a review under clause 7.8.16 and the *System Operator* shall then provide a report to the *Code Participant* and the *Commission* advising of the circumstances requiring such action.

3.9.4 Disconnection to implement an order of the Commission

- (a) The *System Operator* or a *network service provider* may *disconnect* a *Code Participant's facilities* from a *transmission network* or a *distribution network* pursuant to a direction given under clause 11.5.6 and in such circumstances neither the *System Operator* nor the *network service provider* will be liable in any way for any loss or damage suffered or incurred by the *Code Participant* by reason of the *disconnection* and neither the *System Operator* nor the *network service provider* will be obliged for the duration of the *disconnection* to fulfil any agreement to convey electricity to or from the *Code Participant's facility*.
- (b) A *Code Participant* shall not bring proceedings against the *System Operator* or a *network service provider* to seek to recover any amount for any loss or damage described in clause 3.9.4(a).
- (c) *Transmission service charges* and *distribution service charges* shall be paid by a *Code Participant* whose *facilities* have been *disconnected* under this clause 3.9.4 as if any *disconnection* had not occurred unless otherwise provided in a *connection agreement*.

3.9.5 Disconnection during an emergency

Where the *System Operator* may *disconnect* a *Code Participant's facilities* during an emergency under this *Grid Code* or otherwise, then the *System Operator* may:

- (a) request the relevant *Code Participant* to reduce the power transfer at the proposed point of *disconnection* to zero in an orderly manner and then *disconnect* the *Code Participant's facility* by automatic or manual means; or
- (b) immediately *disconnect* the *Code Participant's facilities* by automatic or manual means where, in the *System Operator's* reasonable opinion, it is not appropriate to follow the procedure set out in clause 3.9.5(a) because action is urgently required as a result of a threat to safety of persons, hazard to equipment or a threat to *power system security*.

3.9.6 Obligation to reconnect

- (a) Either the *System Operator* or the relevant *network service provider* shall reconnect a *Code Participant's facilities* to a *transmission network* or *distribution network* at a reasonable cost to the *Code Participant* as soon as practicable if:
- (1) the *System Operator* or *network service provider* is reasonably satisfied that there no longer exists an emergency due to which the *Code Participants facilities* were *disconnected* under clause 3.9.5;
 - (2) the *System Operator* or *network service provider* is reasonably satisfied that there no longer exists a reason for the *disconnection* under applicable laws or the *Code Participant's connection agreement*; or
 - (3) one of the following occurs:
 - (i) a *Code breach* giving rise to *disconnection* has been remedied;
 - (ii) where the breach is not capable of remedy, compensation has been agreed and paid by the *Code Participant* to the affected parties or, failing

agreement, the amount of compensation payable has been determined in accordance with the dispute resolution procedure in clause 11.2 and that amount has been paid;

- (iii) where the breach is not capable of remedy and the amount of compensation has not been agreed or determined, assurances for the payment of reasonable compensation have been given to the satisfaction of the *System Operator*, the *network service provider* and the parties affected; or
 - (iv) the *Code Participant* has taken all necessary steps to prevent the re-occurrence of the breach and has delivered binding undertakings to the *System Operator* or the *network service provider* that the breach will not re-occur.
- (b) In carrying out his obligations under clause 3.9.6(a) the *System Operator* shall, to the extent practicable, implement an equitable sharing of the reconnection of *facilities* up to the *power transfer capability* of the *network* and, in performing these obligations, both the *System Operator* and the relevant *network service provider* shall, to the extent practicable, give priority to reconnection of *sensitive loads*.

SCHEDULES TO CHAPTER 3

TABLE OF CONTENTS

| | Page |
|--|------|
| SCHEDULE 3.1 | |
| NETWORK PERFORMANCE REQUIREMENTS TO BE PROVIDED OR CO-ORDINATED BY NETWORK SERVICE PROVIDERS | 67 |
| SCHEDULE 3.2 | |
| CONDITIONS FOR CONNECTION OF ELECTRIC POWER PRODUCERS | 73 |
| SCHEDULE 3.3 | |
| CONDITIONS FOR CONNECTION OF CONSUMERS | 86 |
| SCHEDULE 3.4 | |
| INFORMATION TO BE PROVIDED WITH PRELIMINARY ENQUIRY | 90 |
| SCHEDULE 3.5 | |
| TECHNICAL DETAILS TO SUPPORT APPLICATION FOR CONNECTION AND CONNECTION AGREEMENT | 91 |
| SCHEDULE 3.6 | |
| TERMS AND CONDITIONS OF CONNECTION AGREEMENTS | 102 |
| SCHEDULE 3.7 | |
| ANNUAL FORECAST INFORMATION FOR PLANNING PURPOSES | 103 |
| SCHEDULE 3.8 | |
| MAXIMUM USE OF SYSTEM PRICE | 104 |

SCHEDULE 3.1

NETWORK PERFORMANCE REQUIREMENTS TO BE PROVIDED OR CO-ORDINATED BY NETWORK SERVICE PROVIDERS

S3.1.1 INTRODUCTION

This schedule describes the planning, design and operating criteria that shall be applied by *network service providers* to the *transmission networks* and *distribution networks* which they own or control. It also describes the requirements for co-ordination between *Code Participants* and *network service providers* to achieve these criteria.

The criteria and the obligations of *Code Participants* to implement them, fall into two categories, namely:

- (a) those required to achieve adequate levels of *network power transfer capability* or quality of *supply* for the common good of all, or a significant number of *Code Participants*; and
- (b) those required to achieve a specific level of *network service* at an individual *connection point*.

A *network service provider* shall:

- (a) fully describe the quantity and quality of *network services* which he agrees to provide to a person under a *connection agreement* in terms that apply to the *connection point* as well as to the *transmission or distribution system* as a whole; and
- (b) ensure that the quantity and quality of those *network services* are not less than could be provided to the relevant person if the Kenyan *network* were planned, designed and operated in accordance with the criteria set out in this schedule 3.1 and recognising that levels of service will vary depending on location of the *connection point* in the *network*.

To the extent that this schedule 3.1 does not contain criteria which are relevant to the description of a particular *network service*, the *network service provider* shall describe the *network service* in terms which are fair and reasonable.

In particular circumstances, the criteria may be varied by *network service providers* and *Code Participants* under a *connection agreement* where it is economic to do so.

However where it is intended to vary these criteria the *Code Participant* proposing to do so shall demonstrate that the variation will not adversely affect other *Code Participants*.

S3.1.2 NETWORK RELIABILITY

S3.1.2.1 Credible contingency events

Network Service providers shall plan, design, maintain and operate their *transmission networks* and *distribution networks* to allow the transfer of power from *generators* to *consumers* with all *facilities* or equipment associated with the *power system* in service and may be required by a *Code Participant* under a *connection agreement* to continue to allow the transfer of power with certain *facilities* or *plant* associated with the *power system* out of service, whether or not accompanied by the occurrence of certain faults (called “*credible contingency events*”).

The following *credible contingency events* and practices shall be used by *network service providers* for planning and operation of *transmission networks* and *distribution networks* unless otherwise agreed by each *Code Participant* who would be affected by the selection of *credible contingency events*:

- (a) The *credible contingency events* shall include the *disconnection* of any single *generator* or *transmission line*, with or without the application of a single circuit two-phase-to-ground solid fault on *electric supply lines* operating at or above 132 kV, and a single circuit three-phase solid fault on *electric supply lines* operating below 132 kV. The *network service provider* shall assume that the fault will be cleared in primary protection time by the faster of the duplicate protections with installed intertrips available. For existing *transmission lines* operating below 132 kV a two-phase to earth fault criterion may be used if the modes of operation are such as to minimise the probability of three-phase faults occurring and operational experience shows this to be adequate, and provided that the *network service provider* upgrades performance when the opportunity arises.
- (b) For *electric supply lines* on metallic structures and at any *voltage* above 66 kV which are not protected by an overhead earth wire and/or *electric supply lines* with tower footing resistances in excess of 10 ohms, the *network service provider* may extend the criterion to include a single circuit three-phase solid fault to cover the increased risk of such a fault occurring. Such *electric supply lines* shall be examined individually on their merits by the relevant *network service provider*.
- (c) For *electric supply lines* at any *voltage* above 66 kV a *network service provider* shall adopt operational practices to minimise the risk of slow fault clearance in case of inadvertent closing on to earths applied to equipment for maintenance purposes. These practices shall include but not be limited to:
- (1) Not leaving *electric supply lines* equipped with intertrips live from one end during maintenance; and
 - (2) Off-loading a three terminal (tee *connected*) line prior to restoration, to ensure switch on to fault *facilities* are operative.
- (d) The *network service provider* shall ensure that all *electric supply lines* at *voltages* of 132 kV and above have two independent high speed protection systems and that all elements of both protection systems, including associated intertripping are well maintained so as to be available at all times other than for short periods (not greater than eight hours) while the maintenance of one protection system is being carried out.

S3.1.2.2 Network service

The following paragraphs of this section set out minimum standards for certain *network services* to be provided to *Code Participants* by *network service providers*. The amount of *network* redundancy provided will be determined by the process set out in Clause 3.6.2 and is expected to reflect the grouping of *generators*, their expected capacity factors and availability and the size and importance of *consumer* groups.

The standard of service to be provided at each *connection point* shall be included in the relevant *connection agreement*, and will include a *power transfer capability* such as that which follows:

- (a) In the satisfactory operating state, the *power system* shall be capable of providing the highest reasonably expected requirement for power transfer (with appropriate recognition of diversity between individual peak requirements and the necessity to withstand *credible contingency events*) at any time.
- (b) During the most critical single element outage the power transfer available through the *power system* may be either:
- (1) Zero (single element supply);

- (2) The defined capacity of a backup *supply*, which, in some cases, may be provided by another *network service provider*;
- (3) A nominated proportion of the normal power transfer capacity (e.g. 70%); or
- (4) The normal power transfer capacity of the *power system* (when required by a *Code Participant*). In the case of S3.1.2.2(b)(2) and (3) the available capacity would be exceeded sufficiently infrequently to allow maintenance to be carried out on each *network* element by the *network service provider*. A *connection agreement* may state the expected proportion of time that the normal capability will not be available, and the capability at those times, taking account of specific design, locational and seasonal influences which may affect performance, and the random nature of element outages. A *connection agreement* may also state a conditional *power transfer capability* that allows for both circuits of a double circuit line or two closely parallel circuits to be out of service.

S3.1.3 FREQUENCY VARIATIONS

The *power system frequency* is determined by *generator commitment, dispatch* managed by the *System Operator*, governor settings advised to *electric power producers* by the *System Operator*, and the setting of under *frequency load shedding* relays co-ordinated by the *System Operator*.

A *network service provider* shall ensure that within the *power system frequency* range 45.0 to 52.0 Hz all of his *power system* equipment will remain in service unless that equipment is required to be switched to give effect to *load shedding* in accordance with clause S3.1.10, or is required by the *System Operator* to be switched for operational purposes. *Plant* shall not be required to operate in a sustained manner outside the range of the *normal operating frequency excursion band* but should remain in service for short-term operation in the range of 45.0 Hz to 52 Hz. The *System Operator* may use *load shedding facilities* (described in paragraph S3.1.10 in this schedule) to aid recovery of frequency to within the normal frequency tolerance band.

S3.1.4 MAGNITUDE OF POWER FREQUENCY VOLTAGE

A *transmission network service provider* shall plan and design extensions of his *network* and equipment for control of *voltage* such that the minimum steady state *voltage* magnitude on the *transmission network* will be 90% of nominal *voltage* and the maximum steady state *voltage* magnitude will be 110% of nominal *voltage*. As the *voltage* limits that apply in different parts of the *power system* are dictated by considerations of economics or *voltage* stability or the design of existing equipment, the *network service provider* shall advise the *System Operator* where a different range of *voltage* magnitude applies.

A requirement for a target range of *voltage* magnitude at a *connection point* shall be specified in the relevant *connection agreement*. This may include a different target range in the satisfactory operating state and after a credible *contingency event* (and how these target ranges may be required to vary with loading). Where more than one *Code Participant* is supplied such that independent control of *voltage* at their *connection points* is not possible a compromise target shall be agreed by the relevant *Code Participants*. Short-time variations (of several minutes duration) within 5% of the intended values shall be considered in the design of *plant* by *Code Participants*.

Short-circuits in different parts of the *network* cause "dips" in the power-frequency phase *voltages* to values which will be dependent on the nature and location of the fault. (During some such faults, one or more of the phase to ground *voltages* may fall to zero

or may rise above the nominal *voltage* level). Typical durations of these dips are between 0.1 and 0.5 seconds, although longer duration dips can occur on *distribution systems*.

A *network service provider* shall ensure that each *facility* that is part of a *transmission network or distribution network* is capable of continuous uninterrupted operation in the event that variations in *voltage* magnitude described in the previous paragraphs occur (other than when the *facility* is faulted).

S3.1.5 VOLTAGE FLUCTUATIONS

A *network service provider* shall include conditions in *connection agreements* in relation to the permissible variation with time of the power generated or *load* taken by a *Code Participant* to ensure that other *Code Participants* are supplied with a power-frequency *voltage* which fluctuates to an extent that is less than the limit defined by the "Threshold of Perceptibility" in IEC 61000.

A *network service provider* shall ensure that *voltage* fluctuations caused by the switching or operation of *network plant* does not exceed the following amounts referenced to IEC 61000:

- (a) the "Threshold of Perceptibility" when all *network plant* is in service and the rate of occurrence of *voltage changes* is equal to or less than once per hour; and
- (b) 80% of the "Threshold of Perceptibility" when all *network plant* is in service and the rate of occurrence of *voltage changes* is more than once per hour; and
- (c) the "Threshold of Irritability" during any credible *contingency event* which is reasonably expected to be of short duration.

Responsibility of a *network service provider* for excursions in *voltage* fluctuations outside the range defined above shall be limited to *voltage* fluctuations caused by *network plant* and the pursuit of all reasonable measures available under the *Grid Code* to remedy the situation in respect of *Code Participants* whose *plant* does not perform to the standards defined by S3.2.5.2 for *electric power producers* and S3.3.7 for *consumers*.

S3.1.6 VOLTAGE HARMONIC OR VOLTAGE NOTCHING DISTORTION

A *network service provider* shall include conditions in *connection agreements* to ensure that the effective harmonic *voltage* distortion to any *connection point* will be limited to less than the levels defined in IEC 61000. In cases where the harmonic distortion is intermittent and repetitive the short duration distortion shall not exceed twice the level of continuous distortion permitted under IEC 61000, and the cumulative duration above the continuous limit shall not exceed 2 seconds in any 30 second period. The above levels exclude *voltage* harmonic distortion produced for a few seconds by events such as switching and fault clearing. The aim of limits is to restrict additional losses, interference and damage to *plant*.

Responsibility of a *network service provider* for harmonic *voltage* distortion outside the range defined above shall be limited to harmonic *voltage* distortion caused by *network plant* and the pursuit of all measures available under the *Grid Code* to remedy the situation in respect of *Code Participants* whose *plant* does not perform to the standards defined by S3.2.5.2 for *electric power producers* and S3.3.8 for *consumers*.

S3.1.7 VOLTAGE IMBALANCE

A *transmission network service provider* shall balance the phases of his *network*, and a *distribution network service provider* or a *consumer* shall balance the current drawn in each phase at each of his *connection points* so as to achieve average levels of negative

sequence *voltage* at all *connection points* that are equal to or less than the values set out in Table S3.1.1 below provided that at any nominal *voltage* the negative sequence *voltage* averaged over any one minute period shall not exceed 2% more frequently than once in any hour.

Table S3.1.1

| Nominal <i>voltage</i> (kV) | Averaging time | Maximum negative sequence <i>voltage</i> (%) | |
|--------------------------------|----------------|--|--------------------|
| | | Normal conditions | Single contingency |
| >100 | 30 minutes | 0.5 | 0.7 |
| | 10 minutes | 1.0 | 1.0 |
| 10-100 | 10 minutes | 1.3 | 1.3 |
| <10 | 10 minutes | 2.0 | 2.0 |

It is not a breach of the above paragraph if larger negative sequence *voltages* occur for a short period resulting from a fault, single pole interruption, line switching, transformer energisation, series or shunt capacitor *bank* energisation or *shunt reactor* energisation within the *power system*.

Responsibility of the *network service provider* for *voltage* imbalance outside the range defined above shall be limited to *voltage* imbalance caused by the *network* and the pursuit of all measures available under the *Grid Code* to remedy the situation in respect of *Code Participants* whose *plant* does not perform to the standards in S3.2.5.2 for *electric power producers* and S3.3.6 for *consumers*.

S3.1.8 STABILITY

The following criteria shall be used by *network service providers* for both planning and operation:

For stable operation of the *power system*, both in a satisfactory operating state and following any *credible contingency events* described in paragraph S3.1.2.1:

- (a) the *power system* will remain in synchronism;
- (b) damping of *power system* oscillations will be adequate; and
- (c) *voltage* stability criteria will be satisfied.

Damping of *power system* oscillations shall be assessed for planning purposes according to the design criteria which states that *power system damping* is considered adequate if after the most critical *credible contingency event*, simulations calibrated against past performance indicate that the halving time of the least damped electromechanical mode of oscillation is not more than five seconds.

To assess the damping of *power system* oscillations during operation, or when analysing results of tests such as those carried out under clause 3.7.7 of the *Grid Code*, the *network service provider* and the *System Operator* shall take into account statistical effects. Therefore, the *power system damping* operational performance criterion is that at a given operating point, real-time monitoring or available test results show that there is less than a 10% probability that the halving time of the least damped mode of oscillation will exceed ten seconds, and that the average halving time of the least damped mode of oscillation is not more than five seconds.

The *voltage* control criterion is that stable *voltage* control shall be maintained following the most severe *credible contingency event*. This requires that an adequate *reactive power* margin shall be maintained at every *connection point* in a *network* with respect to the *voltage* stability limit as determined from the *voltage/reactive load* characteristic at that *connection point*. Selection of the appropriate margin at each *connection point* shall be at the discretion of the relevant *network service provider*, but shall not exceed a capacitive *reactive power* (in MVAR) of 1% of the maximum fault level (in MVA) at the *connection point*.

In planning a *network* a *network service provider* shall consider *non-credible contingency events* such as *busbar* faults which result in tripping of several circuits, uncleared faults, double circuit faults and multiple contingencies which could potentially endanger the stability of the *power system*. In those cases where the consequences to any *network* or to any *Code Participant* of such events are likely to be severe disruption a *network service provider* and/or a *Code Participant* shall install emergency controls within the *network service provider's* or *Code Participant's* system or in both, as necessary, to minimise disruption to any *transmission or distribution network* and to significantly reduce the probability of *cascading outages*.

A *Code Participant* shall cooperate with a *network service provider* to achieve stable operation of the *power system* and shall use all reasonable endeavours to negotiate with the *network service provider* regarding the installation of emergency controls as described in the previous paragraph. The cost of installation, maintenance and operation of the emergency controls shall be borne by the *network service provider* who is entitled to include this cost when calculating the *transmission consumer use of system* price.

S3.1.9 FAULT CLEARANCE TIMES

Code Participants shall ensure that the fault clearance times set out in Table S3.1.2 for both main protections and for *breaker fail* protections are achieved for all *connected plant* owned by any *Code Participant* except as specifically advised by the *network service provider*, and stated in a *connection agreement*. The *network service provider* shall first obtain the prior approval of the *System Operator* before the *network service provider* can advise the *Code Participant* of any such exception.

In order to protect *plant* in the event of a fault and a circuit *breaker failing* to operate, *Code Participants* shall install *breaker fail* (backup) protection equipment to clear the faults within the *breaker fail* times specified in Table S3.1.2 by operating contiguous circuit breakers on the *network* or elsewhere.

The criteria for allowing clearing times longer than the values given in Table S3.1.2, including the requirement for intertrips for *transmission lines* to meet the remote end clearing times, shall be based on consideration of ensuring *power system* stability as determined by the *System Operator* and/or preventing *plant* damage as determined by the *network service provider*.

Table S3.1.2

| Maximum fault clearance time (milliseconds) | | | |
|---|---|------------|---------------------|
| <i>System voltage</i> (kV) | Faulted end | Remote end | <i>Breaker fail</i> |
| > 250 kV | 100 | 120 | 250 |
| 100 kV - 250 kV | 120 | 220 | 430 |
| < 100 kV | As necessary to prevent <i>plant</i> damage and meet stability requirements | | |

S3.1.10 LOAD SHEDDING FACILITIES

S3.1.10.1

To maintain *power system security* the *System Operator* and each *network service provider* shall take all steps necessary to ensure that up to 60% of the *power system load* at any time will be available for *disconnection*:

- (a) under the control of under-frequency relays; and/or
- (b) under manual or automatic control from the National Control Centre or by *distribution system control centres*; and/or
- (c) under the control of under-voltage relays.

A *network service provider* may require *load shedding* arrangements to be installed to cater for abnormal operating conditions.

Arrangements for *load shedding* shall be agreed between *transmission network service providers* and *connected distribution network service providers* and may include the opening of circuits in either a *transmission or distribution network*.

The *transmission network service provider* shall specify, in the *connection agreement*, control and monitoring requirements to be provided by a *distribution network service provider* for *load shedding facilities*.

S3.1.10.2

Where required under a *connection agreement*, a *distribution network service provider* shall:

- (a) provide, install, operate and maintain *facilities* for *load shedding* in respect of any *connection point* at which the maximum *load* exceeds 10 MW;
- (b) co-operate with the *transmission network service providers* in conducting periodic functional testing of the *facilities*, which shall not require *load* to be *disconnected*;
- (c) apply under-frequency settings to relays as determined by the *System Operator*; and
- (d) apply under-voltage settings to relays as determined by the *transmission network service provider*.

S3.1.10.3

Transmission network service providers shall:

- (a) conduct periodic functional tests of the *load shedding facilities*; and
- (b) notify *distribution network service providers* regarding the settings of under-voltage *load shed* relays as advised by the *System Operator*.

S3.1.11 AUTOMATIC RECLOSURE OF OVERHEAD TRANSMISSION LINES

All overhead *transmission lines* forming part of a *transmission network* shall have equipment for either three pole automatic reclose or single pole automatic reclose unless the relevant *transmission network service provider* and the *System Operator* agree otherwise.

When enabled, *automatic reclose equipment* shall operate so as to reclose the circuit breakers following their opening as a result of a *transmission line* fault within a time agreed by the *System Operator* and the *transmission network service provider*.

Check or blocking *facilities* shall be applied to the *automatic reclose equipment* in those circumstances where there is any possibility of the two ends of the *transmission line* being energised from sources that are not in synchronism.

S3.1.12 RATING OF TRANSMISSION LINES AND EQUIPMENT

For operational purposes each *transmission network service provider* shall, on reasonable request, advise the *System Operator* of the maximum current that may be permitted to flow (under conditions nominated by the *System Operator*) through each *transmission line* or other item of equipment that forms part of his *transmission network*.

This maximum current is called a "current rating" of the *transmission line* or item of equipment. For *transmission lines* or equipment where continuous remote monitoring of conductor temperature is available to the *System Operator* then the rating of that *transmission line* or piece of equipment may be specified in terms of a maximum conductor temperature.

The *transmission network service provider* may be required by the *System Operator* to advise different current ratings to be applied under nominated conditions including, without limitation:

- (a) various ambient weather conditions;
- (b) various seasons and/or times of *day*;
- (c) various ratios of the current during an emergency to the current prior to the emergency; and
- (d) various lengths of time that a current may be maintained during an emergency condition.

A *transmission network service provider* is entitled to advise current ratings which apply only where the relevant *transmission line* or item of equipment operates at or below the temperature for which it was designed, except for brief periods of operation above that temperature that do not materially affect the safety of the *transmission line* or item of equipment, or the safety of persons.

A *network service provider* may give a standing instruction to the *System Operator* to *disconnect* a *transmission line* or item of equipment that is operating above a relevant current rating that has been advised to the *System Operator*.

S3.1.13 CONNECTION POINTS

Connection points between the *network service providers* shall be defined in the relevant *connection agreement*.

S3.1.14 REMOTE MONITORING EQUIPMENT

- (a) The *System Operator* may require a *network service provider* to install such equipment to monitor the flow of *energy* through, or the status of elements in a *transmission network* or *distribution network* as is reasonably necessary to allow the *System Operator* to discharge his *dispatch* and *power system security* functions as set out in Chapters 3 and 4 of the *Grid Code* respectively. Monitoring may include such data as current, *voltage*, real and *reactive power* and temperature.
- (b) The *System Operator* may require a *network service provider* to install remote monitoring equipment to enable the *System Operator* to monitor any installation owned or under the control of that *network service provider*.
- (c) The *System Operator* may, by notice given in writing, require a *network service provider* to upgrade, modify or replace any remote monitoring equipment already installed, provided that the existing equipment is, in the reasonable opinion of the *System Operator*, no longer fit for its intended purpose.

SCHEDULE 3.2**CONDITIONS FOR CONNECTION OF ELECTRIC POWER PRODUCERS****S3.2.1 OUTLINE OF REQUIREMENTS**

- (a) This schedule sets out details of the requirements and conditions which (subject to clause 3.2 of the *Grid Code*) *electric power producer* shall satisfy as a condition of *connection* of a *generator* to the *power system*, except where specifically varied in a *connection agreement*. It includes, in respect of each *generator*, the capability to:
- (1) *supply* real power during extreme *voltage* and frequency variations on the *power system*;
 - (2) *supply* real power output when *supply* quality at the *connection point* is at the limit permitted under the *Grid Code*;
 - (3) automatically control its *active power* output by means of a governor system if a *generator* or above a certain size;
 - (4) automatically control its *reactive power* within its range of capability by means of an *excitation control system* if a *synchronous generator*; or to comply with clause S3.3.7 of schedule 3.3 if not a *synchronous generator*;
 - (5) stabilise *power system* oscillatory disturbances by means of *power system* stabilising *facilities* if a *synchronous generator* above a certain size;
 - (6) respond to control requirements under expected normal and abnormal conditions;
 - (7) comply with general requirements to meet quality of *supply* obligations in accordance with clauses 6,7 and 8 of schedule 3.3 and to maintain security of *supply* to other *Code Participants*; and
 - (8) automatically *disconnect* itself when necessary to prevent any damage to the *generator* or threat to *power system security*.
- (b) This schedule also sets out the requirements and conditions, which (subject to clause 3.2.5 of the *Grid Code*) are obligations of *electric power producers* to:
- (1) co-operate with the relevant *network service provider* on technical matters when making a new *connection*; and
 - (2) provide information to the *network service provider* or the *System Operator*.
- (c) This schedule does not set out arrangements by which an *electric power producer* may enter into an arrangement, agreement or contract with the *System Operator* to provide additional services that are necessary to maintain *power system security*.

S3.2.2 TECHNICAL CHARACTERISTICS THAT MAY BE REQUIRED

- (a) If required by the *System Operator* or the relevant *network service provider*, an *electric power producer* shall provide *power system* stabilising *facilities* on each *synchronous generator* that has a nameplate rating greater than 10 MW.
- (b) If required by the *System Operator* or the relevant *network service provider*, an *electric power producer* shall ensure that new *synchronous generators* to have a short circuit ratio of not less than 0.5 if necessary to limit the lessening of *power transfer capabilities* that are determined by transient stability considerations.
- (c) An *electric power producer* shall ensure that each *generator* complies with a specification by a *network service provider* as to the minimum subtransient

reactance that the *generator* may have if necessary to control fault level on the *transmission network or distribution network*.

- (d) If required by the *System Operator*, the *electric power producer* shall install on each *generator*:
- (1) remote control equipment in accordance with paragraph S3.2.6.2; and
 - (2) remote monitoring equipment in accordance with paragraph S3.2.6.1.

S3.2.3 TECHNICAL MATTERS TO BE CO-ORDINATED

An *electric power producer* and the relevant *network service provider* shall use all reasonable endeavours to agree upon the following matters in respect of each new or altered *connection of a generator to a network*:

- (a) design at the *connection point*;
- (b) physical layout adjacent to the *connection point*;
- (c) primary protection and backup protection (paragraph S3.2.5 of this schedule);
- (d) control characteristics (paragraph S3.2.6 of this schedule);
- (e) communications and alarms (paragraph S3.2.6 of this schedule);
- (f) insulation co-ordination and lightning protection;
- (g) fault levels and fault clearance times;
- (h) switching and isolation *facilities* and procedures;
- (i) interlocking arrangements; and
- (j) *metering* installations as described in Chapter 4.

S3.2.4 PROVISION OF INFORMATION

The *electric power producer* shall promptly on request provide all data of the kinds specified in S3.5 reasonably required by the *System Operator* or the *network service provider*.

S3.2.5 DETAILED TECHNICAL REQUIREMENTS REQUIRING ONGOING VERIFICATION

Conformance with the technical requirements described in this section is the responsibility of the *electric power producer* and is required to be demonstrated to the *network service provider* by the *electric power producer* at the times and by the methods described in clause 3.7.3 for each *generator*.

S3.2.5.1 Reactive power capability

Each *synchronous generator* shall be capable of *supplying* a reactive power output coincident with rated real power output such that at the *generator's* terminals at nominal *voltage* the lagging *power factor* is equal to or less than 0.85 and at the same power output the *generator* shall be capable of absorbing reactive power at a leading *power factor* equal to or less than 0.95.

Each *asynchronous generator* shall be compensated by *series or shunt capacitors* so as to *supply* reactive power output to the *network* at the *connection point* such that the *power factor* is in the range unity to 0.95 lagging inclusive coincident with rated real power output.

In the event that these *power factors* cannot be provided the *electric power producer* shall reach a commercial arrangement under the *connection agreement* with the *network*

service provider for the *supply* of the deficit in reactive power as measured at the *generator's* terminals.

S3.2.5.2 Quality of electricity generated

When operating unsynchronised, each *synchronous generator* shall generate a constant *voltage* level with balanced phase *voltages* and harmonic *voltage* distortion equal to or less than permitted in accordance KS IEC 60034 for "General Requirements for Rotating Electrical Machines".

For each *asynchronous generator* the contributions to quality of *supply* shall be not less than that required to be provided by *consumers* as defined in Schedule 3.3 clauses S3.3.6, S3.3.7 and S3.3.8.

S3.2.5.3 Generator response to disturbances in the power system

- (a) Each *generator*, and the power station in which that *generator* is located, shall be capable of continuous uninterrupted operation during the occurrence of:
- (1) *Power system frequency* variation within the frequency limits and bands specified in the *power system security and reliability standards* for periods not longer than the corresponding times specified in the *power system security and reliability standards* for the relevant limit or band.
 - (2) The range of *voltage* variation conditions permitted by Schedule 3.1 paragraph S3.1.4, including the *voltage* dip caused by a *transmission system* fault which causes *voltage* at the *connection point* to drop to zero for up to 0.175 seconds in any one phase or combination of phases, followed by a period of ten seconds where *voltage* may vary in the range 80-110% of the nominal *voltage*, and a subsequent period of three minutes in which the *voltage* may vary within the range 90-110% of the nominal *voltage*.
- (b) All equipment associated with each *generator* shall be designed to withstand without damage or reduction in life expectancy the harmonic distortion and *voltage* imbalance conditions set out in schedule 3.1 paragraphs S3.1.6 and S3.1.7 respectively at the *connection point*.

S3.2.5.4 Partial load rejection

Each *generator* shall be capable of continuous uninterrupted operation during and following a *load* reduction in less than 10 seconds from a fully or partially loaded condition provided that the *load* reduction is less than 30% of the *generator's* nameplate rating and allowing that the *generators* output may be adjusted to avoid rough running bands following automatic control action and the *load* remains above minimum *load* or of such lesser performance as is agreed between the *network service provider* and the relevant *electric power producer* and stated in the *connection agreement* between them. The *network service provider* shall first obtain the prior approval of the *System Operator* before the *network service provider* may agree to a lesser performance with the relevant *electric power producer*.

S3.2.5.5 Loading rates

Each *generator* shall be capable of increasing or decreasing *load* in response to a manually or remotely initiated loading order at a rate not less than 5% of nameplate rating per minute or of such lesser performance as is agreed between the *network service provider* and the relevant *electric power producer* and stated in their *connection agreement*.

The *network service provider* shall first obtain the prior approval of the *System Operator* before the *network service provider* may agree to a lesser performance with the relevant *electric power producer*.

S3.2.5.6 Safe shutdown without external electricity supply

Each *generator* shall be capable of being safely shut down without electricity *supply* available from the *transmission network or distribution network* at the relevant *connection point*.

S3.2.5.7 Restart following restoration of external electricity supply

Each *generator* shall be capable of being restarted and synchronised to the *power system* without unreasonable delay following restoration of external *supply* from the *power system* at the relevant *connection point*, after being without external *supply* for two hours or less, unless the *generator* was *disconnected* due to a fault within the *generator*.

Examples of unreasonable delay in the restart of a *generator* are:

- (a) delays not inherent in the design of the relevant start-up *facilities* and which could reasonably have been eliminated by the relevant *electric power producer*; and
- (b) the start-up *facilities* for a new *generator* not being designed to minimise start up time delays for the *generator* following loss of external *supply* for two hours or less.

S3.2.5.8 Protection of generators from power system disturbances

- (a) An *electric power producer* may require that any *generator* be automatically *disconnected* from the *power system* in response to conditions at the relevant *connection point* which are not within the engineering limits for operating the *generator*. These abnormal conditions may include (without limitation):
 - (1) loss of synchronism;
 - (2) sustained high or low frequency outside the extreme frequency excursion tolerance limits specified in the *power system security* standards;
 - (3) sustained excessive *generator* stator current that cannot be automatically controlled;
 - (4) excessive high or low stator *voltage*;
 - (5) excessive *voltage to frequency* ratio;
 - (6) excessive negative phase sequence current; and
 - (7) loss of field.
- (b) The settings of the protection equipment installed on a *generator* determined by the *electric power producer* to satisfy requirement S3.2.5.8(a) shall be consistent with *power system* performance requirements specified in schedule S3.1 and shall be approved by the *network service provider* and the *System Operator* in respect of their potential to reduce *power system security*. They shall be such as to maximise *plant* availability, to assist the control of the *power system* under emergency conditions and to minimise the risk of inadvertent *disconnection* consistent with the requirements of *plant* safety and durability.

S3.2.5.9 Protection systems that impact on power system security

The requirements of this clause apply only to protection which is necessary to maintain *power system security*. Protection solely for *electric power producer* risks is at the *electric power producer's* discretion.

- (a) Each *generator* and each *generator's transformers* shall be provided with duplicated or complementary protections approved in writing by the relevant *network service provider*, and each protection shall be independently able to *disconnect* the *generator* and/or transformer should faults occur within the relevant protection zones.
- (b) Each set of protection provided in a *generator* to satisfy the requirements of S3.2.5.9 (a) shall operate within a time period advised by the *network service provider* having regard for *network* performance requirements as described in schedule S3.1.
- (c) Unless otherwise stated in a *connection agreement*, backup protection shall be provided by the relevant *electric power producer* for circuit *breaker failure* at the relevant *connection point* and by the *network service provider* for *generator circuit breaker failure* (where provided).

S3.2.5.10 Asynchronous operation

- (a) Unless otherwise approved by the *System Operator* and the *network service provider* and stated in a *connection agreement* between the *network service provider* and the relevant *electric power producer*, each *generator* designed for synchronous operation shall have protection to *disconnect* it in order to prevent pole slipping or asynchronous operation.
- (b) The actual settings of protection installed on a *generator* to satisfy the requirements of S3.2.5.10 (a) shall be approved by the *network service provider* and the *System Operator*.

S3.2.5.11 Frequency responsiveness and governor stability

The governor system response and stability for each *generator* shall comply with the requirements set out in paragraph S3.2.6.4 of this schedule. Each *generator* which is providing governing *ancillary service* may be required by the *System Operator* to be monitored continuously for governor performance compliance, and reports submitted quarterly to the *System Operator* by the relevant *electric power producer* detailing *generator* response for each *power system frequency* excursion outside the *normal operating frequency band*. Reports shall contain graphical information showing response to each such disturbance, including plots of *generator* MW output and *power system frequency*, of appropriate resolution, sampling interval and record duration.

S3.2.5.12 Generator transformer tapping

Unless otherwise agreed between the *network service provider* and the *electric power producer*, the *generator transformer* of each *generator* shall be capable of on-load tap-changing within the range specified in the relevant *connection agreement*.

S3.2.5.13 Excitation control system

The *excitation control system* of each *synchronous generator* shall:

- (a) regulate *generator* stator *voltage*;
- (b) provide *power system* stabilising action if fitted with a *power system* stabiliser;
- (c) limit *generator* reactive power output to within *generator* capabilities; and
- (d) comply with the performance requirements set out in section S3.2.6.5 below.

S3.2.6 MONITORING AND CONTROL REQUIREMENTS

S3.2.6.1 Remote monitoring

(a) The System Operator may require an *electric power producer* to, within a reasonable time of notice being given in writing:

- (1) install remote monitoring equipment ("RME") adequate to enable the *System Operator* to remotely monitor performance of a *generator* (including its dynamic performance) where this is reasonably necessary in real time or with small delay for control, planning or security of the *power system*; and
- (2) upgrade, modify or replace any RME already installed in a power station provided that the existing RME is, in the reasonable opinion of the *System Operator*, no longer fit for the intended purpose.

(b) Input Information to RME may include, (without limitation) the following:

(1) Status Indications

- (i) *generator* circuit breaker open/closed (double pole);
- (ii) remote *generator* control on/off;
- (iii) remote *generator* control high limit reached;
- (iv) remote *generator* control low limit reached;
- (v) *generator* operating mode; and
- (vi) governor limiting operation.

(2) Alarms

- (i) *generator* circuit breaker tripped by protection;
- (ii) prepare to off *load* and
- (iii) urgent and non-urgent alarms

(3) Measured Values

- (i) *Generator active power*;
- (ii) *Generator reactive power*;
- (iii) *Generator stator voltage*;
- (iv) *Generator transformer tap position*;
- (v) *Generator active energy (impulse)*;
- (vi) *Generator remote generation control high limit value*;
- (vii) *Generator remote generation control low limit value*; and
- (viii) *Generator remote generation control rate limit value*.

(4) Such other input information reasonably required by the *System Operator*.

S3.2.6.2 Remote control

The *System Operator* may require an *electric power producer* to, within a reasonable time after giving notice in writing:

(a) install remote control equipment ("RCE") that is adequate to enable the *System Operator* to remotely control:

- (1) the *active power* output of any *generator*; and

- (2) the *reactive power* output of any *generator*; and
- (b) any RCE already installed in a power station to be upgraded, modified or replaced, by notice in writing to the relevant *electric power producer* provided that the existing RCE is, in the reasonable opinion of the *System Operator*, no longer fit for its intended purpose.

Note: Unless agreed otherwise, the relevant *electric power producer* will be responsible for the following actions at the request of the *System Operator*:

- (1) activating and de-activating RCE installed in relation to any *generator*; and
- (2) setting the minimum and maximum levels to which, and a maximum rate at which, the *System Operator* will be able to adjust the performance of any *generator* using RCE.

S3.2.6.3 Communications equipment

An *electric power producer* shall provide electricity supplies for RME and RCE installed in relation to his *generators* capable of keeping such equipment available for at least eight hours following total loss of *supply* at the *connection point* for the relevant *generator*.

An *electric power producer* shall provide communications paths (with appropriate redundancy) from the RME or RCE installed at any of his *generators* to a communications interface in a location reasonably acceptable to the *network service provider* at the relevant power station or *generation control centre*. Communications systems between this communications interface and the National Control Centre shall be the responsibility of the *network service provider* unless otherwise agreed by the *electric power producer* and the *network service provider*.

Telecommunications between *network service providers* and *electric power producers* for *operational communications* shall be established in accordance with the requirements set down below.

(a) Primary speech *facility*

The relevant *network service provider* shall provide and maintain equipment by means of which routine and emergency control telephone calls may be established between the *electric power producer's* responsible Engineer/Operator and the *System Operator*.

The *facilities* to be provided, including the interface requirement between the *network service provider's* equipment and the *electric power producer's* equipment shall be specified by the *network service provider*.

The costs of the equipment shall be recovered by the *network service provider* only through the charge for *connection*.

(b) Back-up speech *facility*

Where the *network service provider* or the *System Operator* reasonably determines that a back-up speech *facility* to the primary *facility* is required, the *network service provider* shall provide and maintain a separate telephone link or radio installation on a cost-recovery basis only through the charge for *connection*.

The *network service provider* shall be responsible for radio system planning and for obtaining all necessary radio licenses.

S3.2.6.4 Governor system

Each *generator* shall have a governor system and each *generator* with a rating of 20 MW and above shall have a governor system which includes *facilities* for both speed and *load* control except where approved by the *System Operator*.

Generators with ratings below 20 MW may use speed based governors where the performance with those governors is acceptable to the *System Operator* and the *network service provider*.

The remaining paragraphs of this sub-clause apply to governor systems of *generators*.

An *electric power producer* shall normally operate each *generator* in a mode (e.g. “boiler-follow” or “load control” mode for thermal units) in which it will respond with a *change* in loading for *changes* in *power system frequency* according to the performance requirements set out in the following paragraphs.

The *electric power producer* shall notify the *System Operator* whenever any *generator* is operated in a mode (e.g. “turbine-follow” mode) where the *generator* is unable to respond as set out in the following paragraphs.

Overall response of a *generator* for system frequency excursions shall be settable and be capable of achieving an increase in the *generator's active power* output of 2 % per 0.1 Hz reduction in system frequency for any initial output up to 85% of rated output and a reduction in the *generator's active power* output of 2% per 0.1 Hz increase in system frequency provided the latter does not require operation below technical minimum. For initial outputs above 85% of rated output response capability shall be able to achieve a linear reduction in response down to zero response at rated output, and the *electric power producer* shall use reasonable endeavours to ensure that the *generator* responds in accordance with this requirement.

Generators shall be capable of achieving an increase in output of at least 5% of their rating for operation below 85% of output. For operation above 85% of rated *load*, the required increase will be reduced linearly with *generator* output from 5% to zero at rated *load*. The *generator* will not be required to increase output above rated *load*.

Generators shall be capable of achieving a decrease in output of at least 10% of their rating for operation at all levels above their technical minimum *loading level* as advised in the registered bid and offer data.

The dead band of a *generator* (being the sum of the increase and the decrease in system frequency before a measurable *change* in the *generator's active power* output occurs) shall be less than 0.1 Hz.

The frequency response and deadband values may be varied by the *electric power producer* with the approval of the *network service provider* under the *connection agreement*. The *network service provider* shall consult the *System Operator* before approving any such variations.

For any frequency disturbance a *generator* shall achieve at least 90% of the maximum response to power *generation* expected according to the droop characteristic within 60 seconds and the new output shall be sustained for 30 seconds.

When a *generator* is operating in a mode such that it is insensitive to frequency variations (including pressure control or turbine follower for a thermal *generator*), the *electric power producer* shall apply a deadband of not greater than 0.25 Hz to ensure that the *generator* will respond for frequency excursions outside the *normal operating frequency band*.

An *electric power producer* shall adjust the governor system of a *generator* to ensure stable performance under all operating conditions with adequate damping. The criterion for adequate damping is that following a step *change* in the governor speed feedback signal the *load* transient oscillations have a minimum damping ratio of 0.4 and the steady state response is within plus or minus 20 per cent of the ideal response having regard to loading rates and deadband.

The *electric power producer* shall advise the *network service provider* of data regarding the structure and parameter settings of all components of the governor control equipment, including the speed/load operator, actuators (for example hydraulic valve positioning systems), valve flow characteristics, limiters, valve operating sequences and steam tables for steam turbine (as appropriate) in sufficient detail to enable the *network service provider* to characterise the dynamic response of these components for short and long term simulation studies. These data shall include a control block diagram in suitable form and proposed settings for the governor system for all expected modes of governor operation.

These parameter settings shall not be varied without prior approval of the *network service provider* and the *System Operator*.

S3.2.6.5 Excitation control system

An *electric power producer* shall ensure that the *excitation control system* of a *synchronous generator* is capable of:

- (a) limiting *generator* operation at all *load* levels to within *generator* capabilities for continuous operation;
- (b) controlling *generator* excitation to maintain the short-time average *generator* stator *voltage* at highest rated level which shall be at least 5% above the nominal stator *voltage* (and is usually 10% above the nominal stator *voltage*);
- (c) maintaining adequate *generator* stability under all operating conditions including providing *power system* stabilising action if fitted with a *power system* stabiliser;
- (d) providing five second ceiling excitation *voltage* at least twice the excitation *voltage* required to achieve maximum continuous rating at nominal *voltage*; and
- (e) unless otherwise agreed by the *network service provider*, providing reactive current compensation settable for boost or droop. An *electric power producer* shall ensure that each new *synchronous generator* is fitted with a fast acting *excitation control system* utilising modern technology. Each *excitation control system* shall provide *voltage* regulation to within 0.5% of the selected setpoint value.

Each *synchronous generator* shall incorporate a *power system* stabiliser circuit which modulates *generator* field *voltage* in response to *changes* in power output and/or shaft speed and/or any other equivalent input signal approved by the *System Operator* except where specifically advised by the *System Operator* that a *power system* stabiliser is not required. The stabilising circuit shall be responsive and adjustable over a frequency range which shall include frequencies from 0.1 Hz to 2.5 Hz.

Table S3.2.1 sets out a minimum performance requirement that shall be achieved by the *electric power producer* for *generators* which have an a.c. exciter, rotating rectifier or static excitation system:

Table S3.2.1: Excitation system performance requirements

| Performance item | Units | Static excitation | A.C. exciter or rotating rectifier | Notes |
|--|-------|-------------------|------------------------------------|-------|
| Sensitivity: A sustained 0.5% error between the <i>voltage</i> reference and the sensed <i>voltage</i> will produce an excitation change of not less than 1.0 per unit. | Gain | 200 minimum | 200 minimum | 1 |
| Field voltage rise time: Time for field <i>voltage</i> to rise from rated <i>voltage</i> to minimum excitation ceiling <i>voltage</i> required by clause S3.2.6.5(d) following the application of a short duration impulse to the <i>voltage</i> reference | s | 0.05 maximum | 0.5 maximum | 2 |
| Settling time with the <i>generator</i> unsynchronised following a disturbance equivalent to a 5% step change in the sensed <i>generator</i> terminal <i>voltage</i> . | s | 1.5 maximum | 2.5 maximum | |
| Settling time with the <i>generator</i> synchronised following a disturbance equivalent to a 5% step change in the sensed <i>generator</i> terminal <i>voltage</i> . Shall be met at all operating points within the <i>generator</i> capability. | s | 2.5 maximum | 5 maximum | |
| Settling time following any disturbance which causes an excitation limiter to operate | s | 5 maximum | 5 maximum | |
| Negative field <i>voltage</i> | - | yes | no | 3 |

Notes:

1. One per unit is that field *voltage* required to produce nominal *voltage* on the air gap line of the *generator* open circuit characteristic (Refer IEEE Standard 115-1983 - Test Procedures for Synchronous Machines).
2. Rated field *voltage* is that *voltage* required to give nominal *generator* terminal *voltage* when the *generator* is operating at its maximum continuous rating. Rise time is defined as the time taken for the field *voltage* to rise from 10% to 90% of the increment value.
3. Negative field current is not required.

The *electric power producer* shall obtain the prior approval of the *network service provider* and the *System Operator* for the structure and parameter settings of all components of the *generator excitation control system*, including the *voltage* regulator, *power system* stabiliser, power amplifiers and all excitation limiters.

The *electric power producer* shall not change, corrector adjust the structure and settings of the *excitation control system* in any manner without prior written notification to the *network service provider*. The *network service provider* shall consult the *System Operator* before approving any such *changes* and may require the *electric power producer* to conduct *generator* tests to demonstrate compliance with requirements of Table S3.2.1. The *network service provider* and the *System Operator* may witness such tests.

The *network service provider* may require the *electric power producer* to alter *generator excitation control system* settings from time to time. The cost of altering the settings and verifying subsequent performance shall be borne by the *electric power*

producer, provided alterations are not made more than once in each 18 months for each *generator*. If more frequent *changes* are requested the person making that request shall pay all costs on that occasion.

Excitation limiters shall be provided by the *electric power producer* on each *generator* for under excitation and over excitation where the *generator* has over or under excitation protection which can trip the *generator* and may be provided for *voltage* to frequency ratio. Each *generator* shall be capable of stable operation for indefinite periods while under the control of any excitation limiter. The *electric power producer* shall ensure that excitation limiters do not detract from the performance of any stabilising circuits and that they have settings applied which are co-ordinated with all protection systems.

S3.2.7 CONNECTION POINT

The *connection point* between an *electric power producer* and a *network* shall be defined in the *connection agreement*.

S3.2.8 POWER STATION AUXILIARY TRANSFORMERS

In cases where an *electric power producer's* power station takes its auxiliary supplies through a transformer via a separate *connection point*, the *electric power producer* shall comply with the conditions for *consumers* (Schedule 3.3) in respect of that *connection point*.

SCHEDULE 3.3**CONDITIONS FOR CONNECTION OF CONSUMERS**

This Schedule sets out obligations of all classes of *consumers* who *connect* to either a *transmission network* or a *distribution network*. It represents typical requirements and particular provisions may be waived at the discretion of the *network service provider* under the provisions of a *connection agreement* where such waiver would have no potential to adversely and materially affect other *Code Participants*.

S3.3.1 INFORMATION

Before a *consumer* connects any new or additional equipment to a *network*, the *consumer* shall submit the following kinds of information (without limitation) to the *network service provider*:

- (a) a single line diagram with the protection details;
- (b) *metering* system design details for any *metering* equipment being provided by the *consumer*;
- (c) a general arrangement locating all the equipment on the site;
- (d) a general arrangement for each new or altered substation showing all exits and the position of all electrical equipment;
- (e) type test certificates for all new switchgear and *transformers*, including measurement *transformers* to be used for *metering* purposes in accordance with Chapter 4;
- (f) earthing details;
- (g) the proposed methods of earthing cables and other equipment to comply with *applicable regulatory instruments*;
- (h) *plant* and earth grid test certificates from approved test authorities;
- (i) a secondary injection and trip test certificate on all circuit breakers;
- (j) certification that all new equipment has been inspected before being *connected* to the *supply*; and
- (k) operational arrangements.

S3.3.2 DESIGN STANDARDS

A *consumer* shall ensure that:

- (a) the new sections of his installation complies with the relevant *Kenya Standards* as applicable at the time;
- (b) all circuit breakers are capable of breaking, without damage or restrike, fault currents nominated by the *network service provider* in the relevant *connection agreement*; and
- (c) all new equipment is capable of withstanding, without damage, power frequency *voltages* and impulse levels nominated by *network service provider* in the relevant *connection agreement*.

S3.3.3 PROTECTION SETTINGS

A *consumer* shall ensure that all *connections* to the *network* are protected by protection devices approved by the *network service provider* which effectively and safely *disconnect* any faulty circuit automatically within a time period specified by the

network service provider. Target fault clearing times are stated in paragraph 3.1.9 of schedule 3.1.

Protection schemes and settings may be specified by a *network service provider* as part of an offer to *connect* or subsequently. Maintenance plans and operational protocols during protection maintenance may also be included in the offer to *connect*.

The *consumer* shall ensure that the protection settings of his protective equipment grade with the *network service provider's transmission system* or *distribution system* protection settings. Similarly the grading requirements of fuses shall be co-ordinated with the *network service provider*. The *consumer* shall provide a description of the protection scheme to the *network service provider* and shall liaise with the *network service provider* when determining gradings and settings.

Before the *consumer's* installation is *connected* to the *network service provider's transmission or distribution system* the *consumer's* protection system shall be tested and the *consumer* shall submit the appropriate test certificate to the *network service provider*.

S3.3.4 CONNECTION POINTS

Connection points between a *consumer's facility* and a *transmission network or distribution network* will be defined in the *connection agreement*.

S3.3.5 POWER FACTOR REQUIREMENTS

Target *power factors* for *consumers* and for *distribution networks connected* to another *transmission network or distribution network* are shown in table S3.3.1:

Table S3.3.1

| Permissible range | |
|---------------------------------|------------------------------|
| <i>Supply voltage</i> (nominal) | <i>Power factor</i> range |
| >250 kV | 0.96 lagging to unity |
| 100kV - 250 kV | 0.95 lagging to unity |
| <100kV | 0.90 lagging to 0.90 leading |

A *network service provider* may permit a lower lagging or leading *power factor* where this will not detrimentally affect system security, or require a higher lagging or leading *power factor* to achieve required *power transfers*.

If the *power factor* falls outside the relevant range in Table S3.3.1 over any critical loading period nominated by the *network service provider* the *consumer* shall, where required by the *network service provider* in order to economically achieve required power transfer levels, take action to ensure that the *power factor* falls within range as soon as reasonably practicable. This may be achieved by installing additional *reactive plant* or reaching a commercial agreement with the *network service provider* to install, operate and maintain equivalent *reactive plant* as part of the *connection assets*.

A *Code Participant* who installs series or shunt capacitors to comply with *power factor* requirements shall comply with the *network service provider's* reasonable requirements to ensure that the design does not severely attenuate audio frequency signals used for *load control* or operations.

S3.3.6 BALANCING OF LOAD CURRENTS

A *network service provider* may require a *connected Code Participant's load* to be balanced at a *connection point* in order to maintain the negative sequence *voltage* at each *connection point* at less than or equal to the limits set out in Table S3.1.1 of schedule 3.1 for the applicable nominal *supply voltage* level.

A *Code Participant* shall ensure that for *connections* at 11 kV or higher *voltage*, the current in any phase is not greater than 102% or less than 98% of the average of the currents in the three phases, or as otherwise approved by the *network service provider*.

Where these requirements cannot be met the *Code Participant* may enter into a commercial arrangement with the *network service provider* for the installation of equipment to correct the phase imbalance. Such equipment shall be considered as part of the *connection assets* for the *Code Participant*.

The limit to *load* current imbalance shall be included in the *connection agreement* and is subject to verification of compliance by the *network service provider*.

S3.3.7 VOLTAGE FLUCTUATIONS

Each *distribution network service provider* or *consumer* shall ensure that variations in current at each of his *connection points* including those arising from the energisation, de-energisation or operation of any *plant* within or supplied from the *distribution network service provider* or a *consumer's* substation (as the case may be) are such that the contribution to the magnitude and rate of occurrence of the resulting *voltage* disturbance does not exceed the following limits:

- (a) where only one *distribution network service provider* or *consumer* has a *connection point* associated with the *point of supply*, the limit is 80% of the threshold of perceptibility set out in IEC 61000; or
- (b) where two or more *distribution network service providers* or *consumers* causing *voltage* fluctuations have a *connection point* associated with a *point of supply*, the threshold of perceptibility limit is to be shared in a manner to be agreed between the *distribution network service provider* and the *Code Participant* in accordance with *good electricity industry practice* that recognises the number of *Code Participants* in the vicinity that may produce *voltage* fluctuations.

The limit to *voltage* fluctuation contribution shall be included in the *connection agreement*, and is subject to verification of compliance by the *network service provider*.

S3.3.8 HARMONICS AND VOLTAGE NOTCHING

Each *distribution network service provider* or *consumer* shall ensure that the level of harmonic current at each of his *connection points* resulting from non-linearity, commutation of power electronic equipment or other effects within the *distribution network* or from supplies drawn from the *distribution network* do not cause the contribution to the level of effective harmonic *voltage* imposed upon any other *Code Participant* to exceed the following limits:

- (a) where only one *distribution network service provider* or *consumer* has a *connection point* associated with the *point of supply* the limits are one third of the limits set out in IEC 61000 for steady state operating conditions; or
- (b) where two or more *distribution network service providers* or *consumers* have a *connection point* associated with the *point of supply*, the harmonic contributions for those that produce harmonics shall be shared in proportion to the respective maximum *demands* of the harmonic producing components, so that the harmonic *voltage* limits in IEC 61000 are not exceeded.

- (c) where harmonic distortion is intermittent and repetitive the permissible distortion is twice that determined according to S3.3.8(a) or S3.3.8(b), provided the cumulative duration above the continuous limit does not exceed 2 seconds in any 30 second period.
- (d) at non-integral harmonic frequencies the inter-harmonic *voltage* attributable to any *distribution network service provider* or *consumer* shall not exceed 0.15% of the *voltage* at the fundamental frequency.

A *Code Participant* shall ensure that all *plant connected* to a *transmission network* or *distribution network* is capable of withstanding the effects of harmonic levels produced by the *Code Participant* plus those imposed from the *network*.

S3.3.9 DESIGN REQUIREMENTS FOR CODE PARTICIPANTS' SUBSTATIONS

A *Code Participant* shall comply with the following requirements applicable to the design, station layout and choice of equipment for a substation:

- (a) Safety provisions shall comply with requirements notified by the *network service provider*;
- (b) Where required by the *network service provider* appropriate interfaces and accommodation shall be incorporated for communication *facilities*, remote monitoring and control and protection of *plant* which is to be installed in the substation;
- (c) A substation shall be capable of continuous uninterrupted operation with the levels of *voltage*, harmonics, imbalance and *voltage* fluctuation specified in schedule 3.1;
- (d) Earthing of primary *plant* in the substation shall be in accordance with the Earthing Guide (to be developed by *electric power producers* or *network service providers* and approved by the *Commission*) and shall reduce step and touch potentials to safe levels;
- (e) Synchronisation *facilities* or reclose blocking shall be provided if a *generator* is *connected* through the substation;
- (f) Secure electricity supplies of adequate capacity shall be provided for *plant* performing communication, monitoring, control and protection functions;
- (g) *Plant* shall be tested to ensure that the substation complies with the approved design and specifications as included in a *connection agreement*;
- (h) The protection equipment required would normally include protection schemes for individual items of *plant*, back-up arrangements, auxiliary d.c. supplies and *instrument transformers*; and
- (i) Insulation levels of *plant* in the substation shall co-ordinate with the insulation levels of the *network* to which the substation is *connected* as nominated in the *connection agreement*.

S3.3.10 LOAD SHEDDING FACILITIES

Consumers having expected *demands* in excess of 10 MW shall provide automatic *interruptible load* to the *System Operator* in accordance with clause 7.3.5 of the *Grid Code*.

SCHEDULE 3.4

INFORMATION TO BE PROVIDED WITH PRELIMINARY ENQUIRY

The following items of information are required to be submitted with a preliminary enquiry for *connection* or modification of an existing *connection*:

- (a) Type of *plant* - (e.g.. gas turbine *generator*; rolling mill, etc.)
- (b) Preferred site location - (listing any alternatives in order of preference as well)
- (c) Maximum power *generation* or *demand* of whole *plant* - (maximum MW and/or MVA, or average over 15 minutes or similar)
- (d) Expected *energy* production or consumption (MWh per month)
- (e) *Plant* type and configuration - (e.g. number and type of *generators* or number of separate production lines)
- (f) Nature of any disturbing *load* (size of disturbing component MW/MVAr, duty cycle, nature of power electronic *plant* which may produce harmonic distortion).
- (g) Technology of proposed *generator* (e.g. *synchronous generator*, induction *generator*, photo-voltaic array, etc)
- (h) When *plant* is to be in service - (e.g. estimated date for each *generator*).
- (i) Name and address of enquirer, and, if relevant, of the party for whom the enquirer is acting.
- (j) Other information may be requested by the *network service provider*, such as amount and timing of power required during construction or any auxiliary power requirements.

SCHEDULE 3.5

TECHNICAL DETAILS TO SUPPORT APPLICATION FOR CONNECTION AND CONNECTION AGREEMENT

S3.5.1

Various sections of the *Grid Code* require that *Code Participants* submit technical data to the *network service provider*. This schedule lists the range of data which may be required.

The actual data required will be advised by the *network service provider*, and will form part of the technical specification in the *connection agreement*. These data will also be made available to the *System Operator* and to other *network service providers* by the *network service provider* at the appropriate time.

S3.5.2

Data is coded in categories, according to the stage at which it is available in the build-up of data during the process of forming a *connection* or obtaining access to a *network*, with data acquired at each stage being carried forward, or enhanced in subsequent stages, e.g.. by testing.

Preliminary system planning data

This is data required for submission with the application, to allow the *network service provider* to prepare an offer of terms for a *connection agreement* and to assess the requirement for, and effect of, *network reinforcement* or extension options. Such data is normally limited to the items denoted as Standard Planning Data (S) in the technical data schedules S3.5.1 to S3.5.5.

The *network service provider* may, in cases where there is reasonable doubt as to the viability of a proposal, require the submission of other data before making an offer to *connect* or to amend a *connection agreement*.

Registered system planning data

This is the class of data which will be included in the *connection agreement* signed by both parties. It consists of the preliminary system planning data plus those items denoted in the attached schedules as Detailed Planning Data (D). The latter shall be submitted by the *Code Participant* in time for inclusion in the *connection agreement*.

Registered data

Registered Data consists of data validated and updated prior to actual *connection* a provision of access from manufacturers' data, detailed design calculations, works or site tests etc. (R1); and data derived from on-system testing after *connection* (R2).

All of the data will, from this stage, be categorised and referred to as Registered Data; but for convenience the schedules omit placing a higher ranked *Code* next to items which are expected to already be valid at an earlier stage.

S3.5.3

Data will be subject to review at reasonable intervals to ensure its continued accuracy and relevance. The *network service provider* shall initiate this review. A *Code Participant* may change any data item at a time other than when that item would normally be reviewed or updated by submission to the *network service provider* of the revised data, together with authentication documents, e.g.. test reports.

The *network service provider* shall supply data relating to his system to other *network service providers* for planning purposes and to other *Code Participants* as specified in the various sections of the *Grid Code*.

S3.5.4

Schedules 3.5.1 to 3.5.5 cover the following data areas:

- (a) Schedule 3.5.1 - *Generator Design Data*. This comprises *generator* fixed design parameters.
- (b) Schedule 3.5.2 - *Generator Setting Data*. This comprises settings which can be varied by agreement or by direction of the *network service provider* or the *System Operator*.
- (c) Schedule 3.5.3 - *Network and Plant Technical Data*. This comprises fixed electrical parameters.
- (d) Schedule 3.5.4 - *Plant and Apparatus Setting Data*. This comprises settings which can be varied by agreement or by direction of the *network service provider* or the *System Operator*.
- (e) Schedule 3.5.5 - *Load Characteristics*. This comprises the estimated parameters of *load* groups in respect of, for example, harmonic content and response to frequency and *voltage* variations.

The schedules applicable to each class of *Code Participant* are as follows:

- (1) *Generators* schedules 3.5.1 and 3.5.2
- (2) *Consumers* and *network service providers* schedules 3.5.3 and 3.5.4
- (3) *consumers* Schedule 3.5.5

S3.5.5

An *electric power producer* that connects a *generator*, that is not a *synchronous generator*, shall be given exemption from complying with those parts of schedules 3.5.1 and 3.5.2 that are determined by the *network service provider* to be not relevant to such *generators*, but shall comply with those parts of Schedules 3.5.3, 3.5.4, and 3.5.5 that are relevant to such *generators*, as determined by the *network service provider*.

S3.5.6

An *electric power producer* that connects a *synchronous generator* equal to or smaller than 2.5 MW or a number of *synchronous generators* totalling less than 2.5 MW to a *connection point* to a *distribution network* will usually be required to submit less registered system planning data and less registered data than is indicated in schedule 3.5.1. In general these data shall be limited to confirmation of the preliminary system planning data, marked (S), but other data shall be supplied if required by the *network service provider* or the *System Operator*.

Codes:

S = Standard Planning Data

D = Detailed Planning Data

R = Registered Data (R1 pre-connection, R2 post-connection)

SCHEDULE 3.5.1:**GENERATOR DESIGN DATA**

| Symbol | Data description | Units | Data category |
|---------------------|---|-------------------|---------------|
| | Power station technical data: | | |
| | <i>Connection point to network</i> | Text, diagram | S, D |
| | Nominal <i>voltage</i> at <i>connection to Network</i> | kV | S |
| | Total station net maximum capacity (NMC) | MW (sent out) | S, D, R2 |
| | <i>At connection point:</i> | | |
| | Maximum 3 phase short circuit infeed calculated by method of AS 3851 (1991) | | |
| | Symmetrical | kA | S, D |
| | Asymmetrical | kA | D |
| | Minimum zero sequence impedance | % on 100 MVA base | D |
| | Minimum negative sequence impedance | % on 100 MVA base | D |
| | Individual <i>generator</i> data: | | |
| M _{BASE} | Rated MVA | MVA | S, D, R1 |
| P _{SO} | Rated MW (sent out) | MW (sent out) | S, D, R1 |
| P _{MAX} | Rated MW (Generated) | MW (Gen) | D |
| VT | Nominal terminal <i>voltage</i> | kV | D, R1 |
| P _{AUX} | Auxiliary <i>load</i> at P _{MAX} | MW | S, D, R2 |
| Q _{max} | Rated reactive output at P _{MAX} | MVAr (sent out) | S, D, R1 |
| P _{MIN} | Minimum <i>load</i> (ML) | MW (sent out) | S, D, R2 |
| H | <i>Generator</i> inertia constant | MWs/rated MVA | D, R1 |
| G _{SCR} | Short circuit ratio | | D, R1 |
| I _{STATOR} | Rated stator current | A | D, R1 |
| I _{ROTOR} | Rated rotor current at rated MVA and <i>power factor</i> , rated terminal volts and rated speed | A | D,R1 |
| V _{ROTOR} | Rotor <i>voltage</i> at which I _{ROTOR} is achieved | V | D, R1 |
| V _{CEIL} | Rotor <i>voltage</i> capable of being supplied for five seconds at rated terminal volts and rated speed | V | D, R1 |

| | | | |
|-------------------|--|----------------------------|--------------|
| | <i>Generator resistance:</i> | | |
| R _A | Stator resistance | % on M _{BASE} | S, D, R1, R2 |
| | <i>Generator reactances (unsaturated):</i> | | |
| X _D | Direct axis synchronous reactance | % on M _{BASE} | S, D, R1, R2 |
| X _{DD} | Direct axis transient reactance | % on M _{BASE} | S, D, R1, R2 |
| | | | |
| X _{DDD} | Direct axis sub-transient reactance | % on M _{BASE} | S, D, R1, R2 |
| X _Q | Quadrature axis synch reactance | % on M _{BASE} | D, R1, R2 |
| X _{QQ} | Quadrature axis transient reactance | % on M _{BASE} | D, R1, R2 |
| X _{QQQ} | Quadrature axis sub-transient reactance | % on M _{BASE} | D,R1, R2 |
| X _L | Stator leakage reactance | % on M _{BASE} | D, R1, R2 |
| X _O | Zero sequence reactance | % on M _{BASE} | D, R1 |
| X _Z | Negative sequence reactance | % on M _{BASE} | D, R1 |
| X _P | Potier reactance | % on M _{BASE} | D, R1 |
| | <i>Generator time constants (unsaturated):</i> | | |
| T _{DO} | Direct axis open circuit transient | Seconds | S, D, R1, R2 |
| T _{DDO} | Direct axis open circuit sub-transient | Seconds | S, D, R1, R2 |
| T _{KD} | Direct axis damper leakage | Seconds | D, R1, R2 |
| T _{QO} | Quad axis open circuit transient | Seconds | D, R1, R2 |
| T _{QQO} | Quad axis open circuit sub-transient | Seconds | D, R1, R2 |
| | Charts: | | |
| G _{CD} | Capability chart | Graphical data | D, R1, R2 |
| G _{OCC} | Open circuit characteristic | Graphical data | R1 |
| G _{SCC} | Short circuit characteristic | Graphical data | R1 |
| G _{ZPC} | Zero power factor curve | Graphical data | R1 |
| | <i>Generator transformer:</i> | | |
| G _{TW} | Number of windings | Text | S, D |
| G _{TRn} | Rated MVA of each winding | MVA | S, D, R1 |
| G _{TTRn} | Principal tap rated <i>voltages</i> | kV/kV | S, D, R1 |
| G _{TZ1n} | Positive sequence impedances (each wdg) | (a + jb) % on 100 MVA base | S, D, R1 |

| | | | |
|------------------------------|--|----------------------------------|-----------|
| G _{TZ2n} | Negative sequence impedances (each wdg) | (a + jb) % on 100 MVA base | S, D, R1 |
| G _{TZO_n} | Zero sequence impedances (each wdg) | (a + jb) % on | S, D, R1 |
| | Tapped winding | Text, diagram | S, D, R1 |
| | Tapped winding | Text, diagram | S, D, R1 |
| G _{TAPR} | Tap change range | kV – kV | S, D |
| G _{TAPS} | Tap change step size | % | D |
| | Tap changer type, on/off load | On/Off | D |
| | Tap change cycle time | Seconds | D |
| G _{TVG} | Vector group | Diagram | S, D |
| | Earthing arrangement | Text, diagram | S, D |
| | Saturation curve | Diagram | R1 |
| | <i>Generator</i> reactive capability (At machine terminals): | | |
| | Lagging reactive power at P _{MAX} | MVA _r export | S, D, R2 |
| | Lagging reactive power at M _L | MVA _r export | S, D, R2 |
| | Lagging reactive short time capability at rated MW, terminal voltage and speed | MVA _r (for time) | D, R1, R2 |
| | Leading reactive power at rated MW | MVA _r import | S,D, R2 |
| | <i>Generator</i> excitation system: | | |
| | DC gain of excitation control loop | V/V | D, R1 |
| | Rated field voltage at rated MVA and power factor and rated terminal volts and speed | V | S, D, R1 |
| | Maximum field voltage | V | S, D, R1 |
| | Minimum field voltage | V | D, R1 |
| | Maximum rate of change of field voltage: | Rising V/sec | D, R1 |
| | Maximum rate of change of field voltage: | Falling V/sec | D, R1 |
| | <i>Generator</i> and exciter saturation | | |
| | Characteristics 50 - 120% V | Diagram | D, R1 |
| | Dynamic characteristics of over Excitation limiter | Text/Block diagram | D, R2 |
| | Dynamic characteristics of under Excitation limiter | Text/Block diagram | D, R2 |
| | <i>Generator</i> load operator: | | |
| | Maximum droop | % | S, D, R1 |
| | Normal droop | % | D, R1 |

| | | | |
|--|---|------------------|----------|
| | Minimum droop | % | D, R1 |
| | Maximum frequency deadband | Hz | D, R1 |
| | Normal frequency deadband | Hz | D, R1 |
| | Minimum frequency deadband | Hz | D, R1 |
| | MW deadband | MW | D, R1 |
| | <i>Generator response capability:</i> | | |
| | Sustained response to frequency change | MW/Hz | D, R2 |
| | Non-sustained response to frequency change | MW/Hz | D, R2 |
| | <i>Load rejection capability</i> | MW | S, D, R2 |
| | <i>Governor:</i> | | |
| | Details of the governor system described in block diagram form showing transfer functions of individual elements and measurement units. | Diagram | D,R2 |
| | Mechanical shaft model: (Multiple-stage steam turbine <i>generators</i> only) | | |
| | Dynamic model of turbine/ <i>generator</i> shaft system in lumped element form showing component inertias, damping and shaft stiffness. | Diagram | D |
| | Natural damping of shaft torsional oscillation modes (for each mode) | | |
| | - Modal frequency | Hz | D |
| | - Logarithmic decrement | Nepers/sec | D |
| | Steam turbine data: (Multiple-stage steam turbines only) | | |
| | Fraction of power produced by each stage: | | |
| | Symbols KHP | Per unit of Pmax | D |
| | KIP | | |
| | KLP1 | | |
| | KLP2 | | |
| | Stage and reheat time constants: | | |
| | Symbols THP | Seconds | D |
| | TRH | | |
| | TIP | | |
| | TLP1 | | |
| | TLP2 | | |
| | Hydraulic turbine model: (Hydro turbine | | |

| | | | |
|--|--|---------|---|
| | <i>generators only</i>) | | |
| | Dynamic model of turbine/water conduit system in lumped element form or distributed parameter form showing component time constants, damping, <i>loss factors</i> , limits, non-linearities and gains. | Diagram | D |
| | General hydraulic data: (hydro turbine <i>generators only</i>) | | |
| | General hydraulic arrangement including all conduit dimensions, Surge tank dimensions, rated head, rated flow at rated head, head losses at rated flow, calculated water start times and turbine efficiency curves | Diagram | D |

SCHEDULE 3.5.2:**GENERATOR SETTING DATA**

| Description category | Units | Data |
|---|----------------|-------|
| Protection data: | | |
| Settings of the following protections: | | |
| Loss of field | Text | D |
| Under excitation | Text, diagram | D |
| Over excitation | Text, diagram | D |
| Differential | Text | D |
| Control data: | | |
| Details of excitation loop described in block diagram form showing transfer functions of individual elements and measurement units. | Diagram | D, R2 |
| Settings of the following controls: | | |
| Over excitation limiter | Text, diagram | D |
| Under excitation limiter | Text, diagram | D |
| Stator current limiter (if fitted) | Text, diagram | D |
| Manual restrictive limiter (if fitted) | Text | D |
| <i>Load</i> drop compensation/VAr sharing (if fitted) | Text, function | D |
| V/f limiter (if fitted) | Text, diagram | D |

SCHEDULE 3.5.3: NETWORK AND PLANT TECHNICAL DATA OF EQUIPMENT AT OR NEAR CONNECTION POINT

| Description | Units | Data category |
|--|----------------------|---------------|
| <i>Voltage rating</i> | | |
| Nominal <i>voltage</i> | kV | S, D |
| Highest <i>voltage</i> | kV | D |
| Insulation co-ordination | | |
| Rated lightning impulse withstand <i>voltage</i> | kVp | D |
| Rated short duration power frequency withstand <i>voltage</i> | kV | D |
| Rated currents | | |
| Circuit maximum current | kA | S, D |
| Rated short time withstand current | kA for seconds | D |
| Ambient conditions under which above current applies | Text | S,D |
| Earthing | | |
| System earthing method | Text | S, D |
| Earth grid rated current | kA for seconds | D |
| Insulation pollution performance | | |
| Minimum total creepage | mm | D |
| Pollution level | Level of IEC 815 | D |
| Controls | | |
| Remote control and data <i>transmission</i> arrangements | Text | D |
| <i>Metering</i> provided by <i>consumer</i> | | |
| Measurement transformer ratios: | | |
| <i>Current transformers</i> | A/A | D |
| <i>Voltage transformers</i> | V/kV | D |
| Measurement transformer test certification details | Text | R1 |
| <i>Network</i> configuration | | |
| Operation diagrams showing the electrical circuits of the existing and proposed main <i>facilities</i> within the <i>Code Participant's</i> ownership including <i>busbar</i> arrangements, phasing arrangements, earthing arrangements, switching <i>facilities</i> and operating <i>voltages</i> . | Single line Diagrams | S, D, R1 |

| | | |
|---|-------------------|----------|
| <i>Network impedances</i> | | |
| For each item of <i>plant</i> : | | |
| details of the positive, negative and zero sequence series and shunt impedances, including mutual coupling between physically adjacent elements. | % on 100 MVA base | S, D, R1 |
| Short circuit infeed to the <i>Network</i> | | |
| Maximum <i>generator</i> 3-phase short circuit infeed including infeeds from <i>generators connected</i> to the <i>Code Participant's</i> system, calculated by method of (Specify the appropriate standard). | kA symmetrical | S, D, R1 |
| The total infeed at the instant of fault (including contribution of induction motors) | kA | D, R1 |
| Minimum zero sequence impedance of <i>Code Participant's network</i> at <i>connection point</i> . | % on 100 MVA base | D, R1 |
| Minimum negative sequence impedance of <i>Code Participant's network</i> at <i>connection point</i> . | % on 100 MVA base | D, R1 |
| <i>Load</i> transfer capability: | | |
| Where a <i>load</i> , or group of <i>loads</i> , may be fed from alternative <i>connection points</i> : | | |
| <i>Load</i> normally taken from <i>connection point X</i> | MW | D, R1 |
| <i>Load</i> normally taken from <i>connection point Y</i> | MW | D, R1 |
| Arrangements for transfer under planned or fault outage conditions | Text | D |
| Circuits connecting <i>embedded generators</i> to the <i>Network</i> : | | |
| For all <i>generators</i> , all connecting <i>electric supply lines/cables, transformers</i> etc. | | |
| Series resistance | % on 100 MVA base | D, R |
| Series reactance | % on 100 MVA base | D, R |
| Shunt susceptance | % on 100 MVA base | D, R |
| Normal and short-time emergency ratings | MVA | D,R |
| Technical Details of <i>generators</i> as per schedules 3.5.1, 3.5.2 | | |
| <i>Transformers</i> at <i>connection points</i> : | | |
| Saturation curve | Diagram | R |

SCHEDULE 3.5.4 - NETWORK PLANT AND APPARATUS SETTING DATA

| Description | Units | Data category |
|---|---------------------------------|---------------|
| Protection data for protection relevant to <i>connection point</i> : | | |
| Reach of all protections on <i>transmission lines</i> , or cables | ohms or % on 100 MVA base | S, D |
| Number of protections on each item | Text | S, D |
| Total fault clearing times for near and remote faults | ms | S, D, R1 |
| Line reclosure sequence details | Text | S, D, R1 |
| Tap change control data: | | |
| Time delay settings of all transformer tap changers. | Seconds | D, R1 |
| Reactive compensation: | | |
| Location and rating of individual <i>shunt reactors</i> | Text & MVar | D, R1 |
| Location and rating of individual series or shunt capacitor <i>banks</i> | Text & MVar | D, R1 |
| <i>Capacitor bank</i> capacitance | Microfarads | D |
| Inductance of switching reactor (if fitted) | Millihenries | D |
| Resistance of capacitor plus reactor | Ohms | D |
| Details of special controls (e.g. Point-on-wave switching) | Text | D |
| For each <i>shunt reactor</i> or <i>capacitor bank</i> : | | |
| Method of switching | Text | S |
| Details of automatic control logic such that operating characteristics can be determined | Text | D, R1 |
| FACTS installation: | | |
| Data sufficient to enable static and dynamic performance of the installation to be modelled | Text, diagrams control settings | S, D, R1 |

SCHEDULE 3.5.5 - LOAD CHARACTERISTICS AT CONNECTION POINT

| Data description | Units | Data category |
|--|---------------------|---------------|
| For all types of <i>load</i> | | |
| Type of <i>load</i> e.g. controlled rectifiers or large motor drives | Text | S |
| For fluctuating <i>loads</i> | | |
| Cyclic variation of <i>active power</i> over period | Graph, MW/time | S |
| Cyclic variation of <i>reactive power</i> over period | Graph, MVar/time | S |
| Maximum rate of change of <i>active power</i> | MW/sec | S |
| Maximum rate of change of <i>reactive power</i> | MVar/sec | S |
| Shortest repetitive time interval between fluctuations in active and <i>reactive power</i> reviewed annually | Seconds | S |
| Largest step change: | | |
| In <i>active power</i> | MW | S |
| In <i>reactive power</i> | MVar | S |

SCHEDULE 3.6 - TERMS AND CONDITIONS OF CONNECTION AGREEMENTS

Code Participants shall enter into legally binding and enforceable *connection agreements* with the *network service provider(s)* which shall require the parties to abide by and comply with the *Grid Code*.

The *connection agreements* shall contain the specific conditions that have been agreed to for *connection* and access to the *transmission or distribution network*, including but not limited to:

- (a) details of the *connection point* including the *distribution network coupling points* where appropriate;
- (b) *metering* arrangements and adjustments for losses where the point of *metering* is significantly different to the *connection point*;
- (c) authorised *demand* which may be taken or supplied at the *connection point* (under specified conditions);
- (d) *connection* service charges;
- (e) payment conditions;
- (f) duration and termination conditions of the *connection agreement*;
- (g) terms, conditions and *constraints* that have been agreed to for *connection* to the *network* to protect the legitimate interest of the *network service providers* including rights to *disconnect* the *Code Participant* for breach of commercial undertakings;
- (h) details of any agreed standards of reliability of *transmission service* or *distribution service* at the *connection points* or within the *network*;
- (i) testing intervals for protection systems associated with the *connection point*;
- (j) agreed protocols for maintenance co-ordination; and
- (k) where an expected *load*, to be *connected* to a *network*, has a *peak load* requirement in excess 10 MW, the provision, installation, operation and maintenance of automatic *load shedding facilities* for 60% of the *load* at anytime.

If a *connection agreement* is between a *distribution network service provider* and an *electric power producer* with an *embedded generator*, the *connection agreement* shall require the *distribution network service provider* to negotiate in good faith a reasonable adjustment to the *use of system* charges payable by the *electric power producer* under the *connection agreement* in light of any *changes* to the *transmission use of system* charges or any other *transmission* charges payable by the *distribution network service provider* as a result of the *electric power producer* being *connected* to his *network*.

The *connection agreements* may include other technical, commercial and legal conditions governing works required for the *connection* or extension to the *network* which the parties have negotiated and agreed to. The circumstances under which the terms of the *connection agreement* would require renegotiation may also be included.

SCHEDULE 3.7 - ANNUAL FORECAST INFORMATION FOR PLANNING PURPOSES

Clause 3.6.1 of the *Grid Code* requires each *Code Participant* that has a *connection point* to a *transmission network* to submit to the *System Operator*, amongst other things, details of yearly forecast *demand* and forecast *generation*. This schedule sets out the information that shall be provided by such *Code Participants* to the *System Operator* in respect of each *connection point*.

| Data description | Units | Time scale | Data category |
|--|---------------|------------|---------------|
| At each <i>connection point</i> to a <i>transmission network</i> , a forecast of: | | | |
| Annual maximum <i>active power</i> | MW | years 1-10 | Annual |
| Coincident <i>reactive power</i> | MVAr | years 1-10 | Annual |
| Annual <i>energy consumption</i> | GWhr | years 1-10 | Annual |
| <i>Load profiles</i> | | | |
| The following forecast daily profiles of <i>connection point</i> half-hourly average active and reactive <i>loads</i> are required, net of all <i>generating plant</i> : | | | |
| <i>Day of the peak MW peak load at connection point</i> | MW and MVAr | years 1-5 | Annual |
| <i>Day of network peak MW load (as specified)</i> | MW and MVAr | years 1-5 | Annual |
| Each July, October, January, April under average conditions representing: | | | |
| (a) weekdays | MW and MVAr | years 1-5 | Annual |
| (b) Saturdays | MW and MVAr | years 1-5 | Annual |
| (c) Sundays/holidays | MW and MVAr | years 1-5 | Annual |
| <i>Day of the peak network minimum demand (as specified)</i> | MW and MVAr l | years 1-5 | Annual |
| <i>Undispatched generation:</i> | | | |
| For each <i>connection point</i> to the <i>network</i> the following information is required: | | | |
| No. of <i>generators</i> | No | years 1-5 | Annual |
| Capacity of each <i>generator</i> | MW (sent out) | years 1-5 | Annual |
| Daily operating characteristics | Text | years 1-5 | Annual |
| Expected output at time of peak <i>network load</i> | MW | years 1-5 | Annual |

SCHEDULE 3.8**MAXIMUM USE OF SYSTEM PRICE**

This schedule 3.9 describes the method by which *network service providers* are to determine the maximum prices to be paid by *electric power producers* for use of *transmission or distribution system*. For *electric power producer connected to a transmission or distribution network* which have elected to enter *electric power producer* access arrangements with the *network service provider*, additional amounts will be payable by the *electric power producer* for the *electric power producer* access risk premium associated with these arrangements. It does not otherwise include *connection charges for electric power producers*.

S3.8.1 LONG RUN MARGINAL COST

Electric power producer use of system price for use of the *network* is to be based on the long run marginal cost of *network reinforcement* required to provide *transmission or distribution service* for new *electric power producers* at a *connection point* in a *transmission network* or in a *distribution network*.

The Long Run Marginal Cost, expressed in \$ per kW, is given by the equation:

$$LRMC = \frac{\text{Net present value of cost of new network investments (\$)}}{\text{Incremental network capacity (kW)}}$$

The *electric power producer use of system price* expressed in \$ per kW per year is determined by expressing the long run marginal cost as an annual charge using a discount rate over a 30 year period equal to the *network owners* weighted average cost of capital, determined in accordance with schedule 5.1

S3.8.2 NEW GENERATION CAPACITY

New *generation capacity* is assumed to be *connected* at each *connection point* where an *electric power producer use of system price* is required. For *transmission networks*, the *network service provider* shall use a new *generation capacity* which is appropriate to the *network location* and may be one of the following:

- (1) the capacity of the largest *generator* already *connected* in the same region as the *connection point*; or
- (2) one quarter of the total generating capacity already *connected* in the same region as the *connection point*; or
- (3) one quarter of the total maximum *demand* of the region in which the *connection point* is located; or
- (4) the forecast annual increase in maximum *demand* over the regulatory review period of the region in which the *connection point* is located; or
- (5) the capacity of the actual new *generation* being installed at the *connection point*. For *distribution networks* the new *generation capacity* is the capacity of *generation* actually installed or to be installed at the *connection point*.

S3.8.3 COST OF NEW NETWORK INVESTMENT

The cost of new *network* investment is the estimated cost of new investments in the *transmission network or distribution network* assuming:

- (1) *network* development, *loads* and *generation* correspond to the current system plus committed development only.
- (2) new *generation* capacity as defined in section 2 above, is *connected* at the *connection point* being examined, and at no other *connection point*.
- (3) *network loads* in the same region as the new *generation* capacity is to be scaled up in proportion to the increase resulting from the new *generation* capacity.
- (4) *network* capacity is to be provided to allow all committed *loads* to be supplied with any one circuit or transformer out of service and with any credible combination of *generation dispatch*.

S3.8.4 - ELECTRIC POWER PRODUCER USE OF SYSTEM PRICE RELATIVE TO THE REFERENCE NODE

For *transmission networks* the long run marginal cost determined in 1 above is to be expressed as the cost of providing *network* capacity for new *generation* at a particular *connection point* relative to the long run marginal cost of providing *network* capacity for new *generation* at the reference node.

This is achieved by subtracting from the long run marginal cost for a particular *connection point*, the long run marginal cost for the reference node.

For *distribution networks*, the *electric power producer use of system* price is further determined in accordance with clause 4.5 of schedule 5.3.

CHAPTER 4 METERING AND RETAIL SUPPLY OF ELECTRICITY

TABLE OF CONTENTS

| | Page |
|--|------|
| 4.1 BULK METERING | 108 |
| 4.1.1 Approved connection points | 108 |
| 4.1.2 Approval of connection points by Commission | 108 |
| 4.1.3 Approval process | 108 |
| 4.1.4 Review of capital works by Commission | 109 |
| 4.1.5 Obligations in relation to approved connection points | 109 |
| 4.1.6 Data collection systems | 109 |
| 4.1.7 Data collection agreements | 109 |
| 4.2 RETAIL SUPPLY OF ELECTRICITY | 110 |
| 4.2.1 Internal credit management policy | 110 |
| 4.2.2 Bills for electricity consumed | 110 |
| 4.2.3 Methods of payment | 111 |
| 4.2.4 Payment difficulties | 112 |
| 4.2.5 Customer Charter | 112 |
| 4.2.6 Information to be provided on request | 112 |
| 4.2.7 Schedule of prices for electricity payable under tariffs | 112 |
| 4.2.8 Consumer's right to information | 112 |
| 4.2.9 Complaint handling and dispute resolution | 113 |
| 4.3 RETAIL METERING | 113 |
| 4.3.1 Metering of supply | 113 |
| 4.3.2 Obligation to install | 113 |
| 4.3.3 Ownership | 113 |
| 4.3.4 Responsibility for metering | 114 |
| 4.3.5 Installation of metering equipment | 114 |
| 4.3.6 Housing of metering equipment | 114 |
| 4.3.7 Impulse output facilities | 114 |
| 4.3.8 Check metering | 115 |
| 4.4 STANDARDS FOR NEW METERING EQUIPMENT | 115 |
| 4.4.1 Type testing | 115 |
| 4.4.2 Demand integration periods | 116 |
| 4.4.3 Storage | 116 |
| 4.5 INSTALLATION TESTING OF NEW METERING EQUIPMENT | 116 |
| 4.6 METERING EQUIPMENT SECURITY | 117 |

| | |
|--|-----|
| 4.6.1 Seals | 117 |
| 4.6.2 Broken seals | 117 |
| 4.7 COLLECTION OF METERING DATA | 117 |
| 4.7.1 Access to metering equipment | 117 |
| 4.7.2 Collection | 118 |
| 4.7.3 Discrepancies | 118 |
| 4.7.4 Processing metering data from half hour metering equipment | 118 |
| 4.8 FIELD TESTING | 118 |
| 4.8.1 Obligation to field test | 118 |
| 4.8.2 Method of field testing | 118 |
| 4.8.3 Costs of field testing | 120 |
| 4.8.4 Field testing procedures | 120 |
| 4.9 MAINTENANCE TESTING | 120 |
| 4.9.1 Maintenance plan | 120 |
| 4.9.2 CT metered electrical installations | 120 |
| 4.9.3 Direct metered electrical installations | 121 |
| 4.10 DEFECTIVE METERING EQUIPMENT | 121 |
| 4.10.1 Repair or replace | 121 |
| 4.10.2 Substitute readings | 121 |
| 4.10.3 Cost of repair or replacement | 121 |
| 4.11 OBLIGATIONS IN RESPECT OF METERING DATA | 122 |
| 4.11.1 Access | 122 |
| 4.11.2 Storage | 122 |
| 4.11.3 Confidentiality | 122 |
| 4.11.4 Ownership of metering data | 123 |
| SCHEDULES TO CHAPTER 4 | 124 |

CHAPTER 4 METERING AND RETAIL SUPPLY OF ELECTRICITY

This Chapter 4 applies to:

- (a) *electric power producers*;
- (a) *transmission network service providers*;
- (a) *distribution network service providers*;
- (b) *public electricity suppliers*; and
- (c) *consumers*

4.1 BULK METERING

This clause 4.1 applies to bulk *metering* between and among *electric power producers transmission network service providers, distribution network service providers public electricity suppliers* and large *consumers*.

4.1.1 Approved connection points

- (a) Each *network service provider* shall, in accordance with this clause 4.1, submit to the *Commission* for approval a statement setting out:
 - (1) a list of *connection points* in respect of which he is seeking approval for the purposes of this Chapter; and
 - (2) in respect of each such *connection point* such details as are required by the *Commission* in relation to the capital works proposed to be undertaken by or on behalf of the *network service provider* in relation to the *metering* installation at the *connection point* for the purpose of meeting his obligations under clause 4.1.4.
- (b) A *network service provider* shall, within a reasonable time following a request by the *Commission*, provide to the *Commission* any additional information requested by the *Commission* in relation to the statement submitted to the *Commission* by the *network service provider* under clause 4.1.2(a).
- (c) A *network service provider* may submit more than one statement to the *Commission* under this clause 4.1.2.

4.1.2 Approval of connection points by Commission

- (a) The *Commission* may approve a *connection point* listed on a statement submitted by the *network service provider* under clause 4.1.1(a), having regard to whether at that *connection point* the *metering* installation need comply or is reasonably likely to need to comply with the requirements of the *Grid Code* in order that the relevant *public electricity supplier* or *electric power producer* may become registered as *Code Participant*.
- (b) The *Commission* shall not approve a *connection point* listed on a statement submitted by the *network service provider* under clause 4.1.1(a) unless, in the *Commission's* opinion, the criteria set out in clause 4.1.2(a) are met in relation to that *connection point*.

4.1.3 Approval process

The *Commission* shall within 30 *business days* from receipt of the statement submitted and any additional information reasonably requested by the *Commission* notify the *network service provider* in relation to each *connection point* listed on a statement submitted by the *network service provider* under clause 4.1.1(a), whether it has approved the *connection point* for the purposes of this Chapter.

4.1.4 Review of capital works by the Commission

- (a) The *Commission* shall review the proposed capital works to be undertaken in relation to an *approved connection point*.
- (b) The *Commission* is to form a view as to whether the proposed capital works for the *metering* installation at that *connection point* are necessary or reasonably likely to be necessary to meet the requirements of the *Grid Code* in order that the relevant *public electricity supplier* or *electric power producer* may become registered as a *Code Participant*.

4.1.5 Obligations in relation to approved connection points

- (a) A *network service provider* shall ensure that at each *approved connection point* there is a *metering* installation that meets the requirements for *metering* installations set out in the *Metering* regulations.
- (b) The compliant *metering* installation shall be installed within the time specified in the notice of approval issued under clause 4.1.3. This date may be amended by agreement with the *Commission*.
- (c) Compliance for the purposes of the notice of approval under clause 4.1.3 may be established from an initial reading consistent with the advised requirements of the *Commission* or as otherwise submitted by the *network service provider* and agreed upon by the *Commission*.

4.1.6 Data collection systems

- (a) A *Code Participant* shall:
 - (1) set out the specifications with which each *metering* installation shall comply;
 - (2) provide a *data collection system*, and
 - (3) maintain a *metering* register, in respect of each *metering* installation at a *connection point* at which that *Code Participant's* equipment is *connected* to the equipment of another *Code Participant*
- (b) A *Code Participant* shall ensure that the provision of the *data collection system* and maintenance of the *metering* register pursuant to clause 4.1.6(a)(2) and (3) are ring-fenced from any other activities performed by that *Code Participant* in accordance with the ring fencing:
 - (1) provisions set out in chapter 10 of the *Grid Code*; and
 - (2) guidelines issued by the *Commission* from time to time, in accordance with Chapter 10 of the *Grid Code*;

4.1.7 Data collection agreements

- (a) The activities contemplated in clause 4.1.6(a)(2) and (3) may be provided by the *Code Participant* himself or by another person with whom the *Code Participant* may enter into an agreement.
- (b) The *Commission* may issue guidelines from time to time in relation to the content of an agreement required under clause 4.1.7(a).
- (c) Dispute resolution procedures under the *Grid Code* shall to apply to any dispute under or in relation to any agreement entered into pursuant to clause 4.1.7(a).
- (d) A *Code Participant* shall lodge an agreement referred to in clause 4.1.7(a) with the *Commission*.

- (e) Subject to clause 4.1.7(f), the *Commission* shall:
- (1) publish a draft or final agreement lodged under this clause 4.1.7; and
 - (2) upon request, make a copy of a final or draft agreement lodged under this clause 4.1.7 available to any person.
- (f) The *Commission* shall ensure that any confidential information contained in an agreement lodged under this clause 4.1.7 is not published or divulged to any person.
- (g) The *Commission* may review an agreement lodged under this clause at any one or more of the following times:
- (1) at any time determined by the *Commission*;
 - (2) if requested by a *Code Participant*;
 - (3) if requested by a person whom the *Commission* considers to be a potential new entrant.

4.2 RETAIL SUPPLY OF ELECTRICITY

- (a) This section applies to *distribution network service providers, public electricity suppliers, and consumers*.
- (b) *Public electricity suppliers* are required to comply with the provisions of this clause 4.2 in relation to the retail *supply* of electricity to *consumers*.

4.2.1 Internal credit management policy

A *public electricity supplier* shall submit to the *Commission* for review documentation of the internal credit management policy and procedures pertaining to *consumers* and any amendments proposed to such internal credit management policy and procedures from time to time.

4.2.2 Bills for electricity consumed

- (a) An *electricity bill* issued by a *public electricity supplier* to a *consumer* shall set out:
- (1) the consumption or the estimate of consumption on which the *electricity bill* is based (including any relevant meter readings, the dates on which they were made and the number of *days* in the period to which the *electricity bill* relates);
 - (2) the relevant tariff;
 - (3) the amount due for electricity consumed; and
 - (4) the amount of any arrears or credit.
- (b) The *electricity bill* shall also set out:
- (1) fixed charges (separately listing each such charge);
 - (2) any fees for meter readings made at the request of the *consumer* and any fees for *connection, disconnection, or reconnection*;
 - (3) any discount to which the *consumer* is entitled (providing an indication of the principles on which the discount is calculated);
 - (4) any concession to which the *consumer* is entitled (providing an indication of the principles on which the concession is calculated);
 - (5) any charge for default or delay in payment (providing an indication of the principles on which the charge is calculated);

- (6) if any payment is required by way of security deposit, the amount of the payment;
 - (7) if any security is held, the amount of the security;
 - (8) any amount that is subject to dispute between the *consumer* and the *public electricity supplier*;
 - (9) how payment may be made;
 - (10) the date on which payment is due;
 - (11) a telephone number at which telephone inquiries may be made relating to electricity accounts;
 - (12) a telephone number at which the *public electricity supplier* may be contacted in an emergency; and
 - (13) a telephone number specifically identified as a telephone number at which the *public electricity supplier* may be contacted when a *consumer* is experiencing difficulty paying an *electricity bill*.
- (c) An *electricity bill* shall be based on consumption of electricity as indicated by meter readings, subject to the following exceptions:
- (1) where the relevant tariff is not based on consumption, the *electricity bill* is to be prepared on the basis contemplated in the tariff; and
 - (2) where a reliable meter reading cannot be obtained for any reason, the *electricity bill* may be based on a reasonable estimate of consumption and, if a reliable meter reading becomes available later, the *electricity bill* shall be adjusted to reflect actual consumption.

4.2.3 Methods of payment

- (a) A *public electricity supplier* shall provide for the following methods of payment:
- (1) payment in person at an office of the *public electricity supplier* or an *agent of the public electricity supplier*;
 - (2) payment by mail;
 - (3) payment by *consumers* having a credit-card or other account to which the amount to be paid by the *consumer* may be directly debited; and
 - (4) payment by direct debit.

4.2.4 Payment difficulties

- (a) A payment plan offered by a *public electricity supplier* to a *consumer* experiencing difficulty in paying an electricity bill or electricity bills may make provision for one or more of the following:
- (1) payment by instalments;
 - (2) payment for future electricity needs and any arrears by pre-payment *metering*;
 - (3) debiting of payments as they fall due under the plan to the *consumer's* account with a bank or other financial institution;
 - (4) where the payment plan pertains to an electricity account for *supply* to a site which is a business premises, payment of interest for deferral of payment in accordance with the tariff.

- (b) A *public electricity supplier* who agrees to enter into a payment plan with a *consumer* shall within 4 *business days* provide written details of the payment plan including details of the number and amount of the payments required under the plan.

4.2.5 Customer Charter

- (a) A *public electricity supplier* shall prepare a *Customer Charter* approved by the *Commission*:
- (1) stating the services and the level and standard of such services that a *consumer* is entitled to receive from the *public electricity supplier*;
 - (2) stating the basis on which electricity bills are to be prepared and the frequency of issue;
 - (3) stating the means of payment and the options available to the *consumer*;
 - (4) describing how to make an inquiry or complaint to the *public electricity supplier* or to the *Commission*; and
 - (5) including a telephone number at which the *public electricity supplier* can be contacted, at any time, in an emergency.
- (b) The *public electricity supplier*:
- (1) shall send or give a copy of the *Customer Charter* to each existing *consumer* within 6 months after the *commencement date*; and
 - (2) shall send or give a copy of the *Customer Charter* to a new *consumer* at or before the time the *public electricity supplier* sends the first electricity bill for electricity supplied.

4.2.6 Information to be provided on request

- (a) A *public electricity supplier* shall in good faith, at the request of a *consumer*, provide the *consumer* with a reasonable level of advice about:
- (1) the tariff that will provide an electricity *supply* at the least cost to the *consumer* in the *consumer's* circumstances; or
 - (2) appropriate strategies for managing electricity consumption on a cost-effective basis.
- (b) The advice shall be provided in writing within 10 *business days* after the date of the request.
- (c) The advice is to be provided free of charge.

4.2.7 Schedule of prices for electricity payable under tariffs

- (a) A *public electricity supplier* shall prepare and keep up to date a schedule setting out the current prices for electricity payable under tariffs.
- (b) The schedule shall be in a form approved by the *Commission*.
- (c) The *public electricity supplier* shall, at the request of a *consumer*, provide the *consumer* at reasonable cost, with a copy of the schedule within 10 *business days* after the date of the request.

4.2.8 Consumer's right to information

If personal information recorded by a *public electricity supplier* in relation to a *consumer* is incorrect, the *public electricity supplier* shall, at the request of the *consumer*, correct the record.

4.2.9 Complaint handling and dispute resolution

- (a) *Public electricity suppliers* and the *distribution network service providers* shall:
- (1) have adequate staff and effective procedures for dealing with complaints and resolving disputes with *consumers*; and
 - (2) shall publish information in a form approved by the *Commission* to assist *consumers* to register complaints and participate in procedures for the resolution of disputes.
- (b) Complaints shall be dealt with in accordance with the *Complaint Handling and Dispute Resolution Procedures* of the *Commission*.

4.3 RETAIL METERING

This clause 4.3, dealing with the *supply* of electricity to electrical installations of *consumers*, applies to:

- (a) *distribution network service providers*;
- (b) *public electricity suppliers* and.
- (c) *consumers*.

4.3.1 Metering of supply

Subject to any agreement between a *public electricity supplier* and a *consumer*, the *distribution network service provider* is responsible for providing, and maintaining in good condition, a meter to measure the *consumer's* consumption of electricity on the basis contemplated in the applicable tariff and in accordance with any relevant code.

4.3.2 Obligation to install

- (a) Subject to clause 4.3.2(c), if a *consumer* requests a *supply* of electricity to an electrical installation of the *consumer* and the electrical installation does not contain *metering* equipment then the *distribution network service provider* shall provide and install *new metering equipment* to measure and record the amount of electricity so supplied.
- (b) Subject to clause 4.3.2(c), if the tariff payable for the sale of electricity in respect of an electrical installation *changes* and that *change* renders the relevant *existing metering equipment* incapable of appropriately measuring and recording the amount of electricity supplied to that electrical installation, then the *distribution network service provider* shall provide and install *new metering equipment* to appropriately measure and record the amount of electricity so supplied.
- (c) If the cost of installing, testing and maintaining *new metering equipment* to measure and record the amount of electricity supplied to an electrical installation of a *consumer* is likely, in the reasonable opinion of the *distribution network service provider*, to exceed the amounts to be paid for the *supply* and sale of electricity to the *consumer* in respect of that electrical installation, the *distribution network service provider* and the *consumer* may agree to determine the amount of electricity so supplied on a basis which does not involve the use of *metering equipment*.

4.3.3 Ownership of metering equipment

Subject to any pre-existing agreement between a *distribution network service provider* and a *consumer*, a *consumer* does not have a proprietary interest in *metering equipment* installed by a *distribution network service provider*.

4.3.4 Responsibility for metering equipment

The *distribution network service provider* shall be responsible for *metering* in relation to the *supply* of electricity to *consumers*.

4.3.5 Installation of metering equipment

- (a) A *distribution network service provider* shall install *new metering equipment* at or as near as practicable to the *point of supply* between his *distribution system* and the electrical installation of a *consumer*, in a position which is:
- (1) readily accessible to any person whose obligation it is to test, adjust maintain, repair or replace the *new metering equipment*; and
 - (2) in cases where the electrical installation of the *consumer* is located on premises the area of which is greater than 0.4 hectares, approved by the *distribution network service provider*.
- (b) Where a *distribution network service provider* installs *new metering equipment* otherwise than at the *point of supply* between his *distribution system* and the electrical installation of a *consumer*, the *distribution network service provider* shall:
- (1) ensure that the *new metering equipment* is able accurately to correct for losses of electricity between the point at which the *new metering equipment* is installed and the *point of supply*; or
 - (2) agree with the *consumer* on the procedure for adjusting the *metering* data to take into account losses of electricity between the point at which the *new metering equipment* is installed and the *point of supply*.
- (c) Subject to clause 4.3.5(d) and this Chapter 9, the cost of installing *new metering equipment* is to be borne by the *distribution network service provider*.
- (d) If a *consumer* requests the *distribution network service provider* to install a type of *new metering equipment* which is different from the type the *distribution network service provider* otherwise would install, then the *consumer* is to bear any costs incurred by the *distribution network service provider* installing that *new metering equipment* in excess of those which the *distribution network service provider* would have incurred in installing the other type of *new metering equipment*.

4.3.6 Housing of metering equipment

The *public electricity supplier* shall use reasonable endeavours to ensure that the *consumer* understands that he has an obligation to provide and maintain:

- (a) fireproof housing for *metering equipment* to the satisfaction of the *distribution network service provider*; and
- (b) if *metering equipment* is housed in a room, reasonably unhindered access to the *metering equipment* and the room in which it is housed.

4.3.7 Impulse output facilities

- (a) A *consumer* may request the *distribution network service provider* to provide him with impulse outputs representing the quantities of electricity measured.
- (b) A *distribution network service provider* shall provide impulse output *facilities* within a reasonable time of being requested by a *consumer* to provide such *facilities*.

- (c) Each impulse out put other than that representing the end of the measurement period shall provide a number of pulses in each integrating period commensurate with the accuracy class of the *metering equipment* when operating at the top of the range of measurement of the *metering equipment*.
- (d) The *consumer* requesting the impulse output shall pay the *distribution network service provider's* reasonable costs of providing such *facilities*.

4.3.8 Check metering

- (a) A *consumer* may at his own cost provide and install *check metering*.
- (b) The person that owns or controls the site at which the *metering equipment* is installed and the person who owns the *metering equipment* shall co-operate with the *consumer* wishing to install *check metering* at that site.
- (c) *Check metering* installed by a *consumer* under this clause 4.3.8 may only be used for the purpose of checking *metering data* or substituting readings where the *check metering* complies, in the case of a *consumer* which has installed *half hour metering equipment* for *metering installations* at *approved connection points*, with the standards determined in accordance with Chapter 7 and in all other cases with this Chapter 4.
- (d) If a *consumer* installs *check metering* for the purposes of checking *metering data* or substituting readings, the *consumer* shall notify the *distribution network service provider*.

4.4 STANDARDS FOR NEW METERING EQUIPMENT

4.4.1 Type testing

- (a) A *distribution network service provider* shall not adopt a type of *new metering equipment* for installation unless tests have been carried out which demonstrate that the type meets the relevant minimum standards for *new metering equipment* as set out in clause 9.11.
- (b) The testing referred to in clause 9.3.1(a) shall be carried out at a laboratory accredited for testing *energy* measuring equipment to the accuracy standard required by the minimum standards.
- (c) A *distribution network service provider* shall keep records of tests under clause 9.3.1(a) while meters of that type remain in service, or for a minimum of seven years, whichever is the longer period.
- (d) *Metering equipment* of a type in service in Kenya on the *commencement date* will be deemed to comply with the requirements prescribed by this clause 4.4.1 and clause 9.11.
- (e) Modifications to *existing metering equipment* shall be assessed by a *distribution network service provider* to determine whether the modified design continues to meet the minimum standards. If the *distribution network service provider* has reasonable grounds to believe that the modifications will affect the measuring capability of the *metering equipment*, then the *metering equipment* shall be resubmitted for type testing.
- (f) If a *public electricity supplier* requires a *distribution network service provider* to install a specific type of *metering equipment* and that *metering equipment* has not previously been used by the *distribution network service provider*, the *public electricity supplier* shall provide evidence that the *metering equipment* has been

tested in accordance with the *Grid Code* or shall meet the costs incurred by the *distribution network service provider* in having the *metering equipment* so tested.

4.4.2 Demand integration periods

- (a) Where tariffs for the sale of electricity to a *consumer* in respect of an electrical installation are based on a 15 minute *demand* integration period, then the start of each integration period shall be on the hour, on the half hour, and on each quarter of an hour.
- (b) Where tariffs for the sale of electricity to a *consumer* in respect of an electrical installation are based on a 30 minute *demand* integration period, then the start of each integration period shall be on the hour, and on the half hour.
- (c) The *distribution network service provider* shall ensure that *metering equipment* complies with the requirements set out in clause 9.12 in relation to switching and time keeping.

4.4.3 Storage

Metering equipment, other than prepayment meters, shall be able to store internally records of the amount of electricity supplied to a *consumer's* electrical installation for at least as long as the intervals between the rendering of electricity bills on the *consumer* by the *distribution network service provider* or *public electricity supplier*.

4.5 INSTALLATION TESTING OF NEW METERING EQUIPMENT

- (a) A *distribution network service provider* shall carry out, or cause to be carried out, an accuracy test to ascertain whether the *new metering equipment* meets the relevant minimum standards either:
 - (1) prior to installation, on each individual *active energy meter*, *reactive energy meter*, *current transformer* and *voltage transformer*; or
 - (2) at the time of commissioning, on the installed *metering equipment*.
- (b) A test under clause 4.3.10(a):
 - (1) shall be carried out using equipment whose calibration is traceable to the Kenyan *energy* standards maintained by KEBS, and
 - (2) shall take into account the currents and *power factors* under which the equipment will operate in practice, and shall take into account lightly loaded and heavily loaded conditions.
- (c) If a test carried out under clause 4.3.10(a) demonstrates that the *new metering equipment* does not meet the relevant minimum standard, the *distribution network service provider* shall not install that *new metering equipment*, or if the *new metering equipment* has been installed shall replace all non-compliant *new metering equipment*.
- (d) The *distribution network service provider* shall keep records of the test of the *new metering equipment* under clause 4.3.10(a) while *metering equipment* of that type remains in service, or for a minimum of 7 years, whichever is the longer period.

4.6 METERING EQUIPMENT SECURITY

4.6.1 Seals

- (a) A *distribution network service provider* and, where electricity is sold to a *consumer* by a *public electricity supplier*, the *public electricity supplier*, shall use their best endeavours to protect *metering equipment* from unauthorised interference.
- (b) A *distribution network service provider* shall :
 - (1) in respect of *new metering equipment* provide seals or other appropriate devices to detect such interference;
 - (2) maintain a register of all relevant security fitting tools and seals; and
 - (3) restrict electronic access to meters by the use of passwords and similar for ms of security.

4.6.2 Broken seals

- (a) If a *distribution network service provider* or a *public electricity supplier* discovers that a seal protecting *metering equipment* has been broken, he shall notify the other party within 5 *business days*.
- (b) A *distribution network service provider* shall replace a broken seal on the first occasion the *metering equipment* is visited to take a reading after receiving notification under clause 4.6.2(a), or within 100 *days*, whichever is the earlier.
- (c) The costs of replacing seals which are broken otherwise than during a test under clause 4.3.13 are to be borne as follows:
 - (1) if the seal was broken by the *consumer*, by the *consumer*;
 - (2) if the seal was broken by the *public electricity supplier*, by the *public electricity supplier*; or
 - (3) otherwise, by the *distribution network service provider*.
- (d) If it appears that, as a result of or in connection with the breaking of a seal, the relevant *metering equipment* may no longer meet the relevant minimum standard, then the *distribution network service provider* shall test the *metering equipment* in accordance with clause 4.3.13 and clause 4.3.15.

4.7 COLLECTION OF METERING DATA

4.7.1 Access to metering equipment

- (a) A *public electricity supplier* shall advise each of his *consumers* that they must at all times make available to the *distribution network service provider's agents*, together with their equipment, safe, convenient and unhindered access to *metering equipment* on the *consumer's* premises for any purpose associated with *metering* or billing.
- (b) Where *metering equipment* used to measure and record the amount of electricity supplied to a *consumer* is not located on the *consumer's* premises the *distribution network service provider* shall make available to the *consumer* safe, convenient and unhindered access to the *metering equipment* or the relevant *metering data*.

4.7.2 Collection

In relation to the *supply* of electricity to a *consumer*, a *distribution network service provider* shall collect data stored in *metering equipment* as frequently as is required to enable him to discharge his obligations and exercise his rights under this Chapter 9, either by:

- (a) inspecting the *metering equipment*; or
- (b) electronic means.

4.7.3 Discrepancies

Where electricity is supplied to a *consumer* (which does not have installed *half hour metering equipment*), if there is any discrepancy between:

- (a) the data stored in *metering equipment*; and
- (b) *metering data* in respect of that *metering equipment*, the data stored in the *metering equipment* is to be prima facie evidence of the amount of electricity supplied to the *facilities* of the relevant *consumer*.

4.7.4 Processing metering data from half hour metering equipment

- (a) A *distribution network service provider* shall obtain approval from the *Commission* of his procedures for:
 - (1) validating *metering data*;
 - (2) adjusting *metering data* for situations where *metering data* is incomplete; and
 - (3) providing substitute readings for situations where *metering equipment* is found to be *defective*.
- (b) If a *distribution network service provider* or a *public electricity supplier* makes an adjustment to *metering data* or substitutes a reading, he shall do so in accordance with procedures approved by the *Commission* under clause 4.7.4(a) and he shall:
 - (1) inform the *consumer* when an adjustment or substitution is made;
 - (2) maintain a separate record of the adjustment or substitution for seven years; and
 - (3) provide access to that record at reasonable times to the relevant *consumer*.

4.8 FIELD TESTING

4.8.1 Obligation to field test

A *distribution network service provider* may at any time, and shall within 15 *business days* of a request from a *consumer*, test *metering equipment* which has been installed to measure and record the amount of electricity supplied to an electrical installation of the *consumer* to ascertain whether or not the *metering equipment* is *defective*.

4.8.2 Method of field testing

- (a) A *distribution network service provider* shall test *metering equipment* under clause 4.8.1 by:
 - (1) measuring the errors of the *metering equipment* using equipment the calibration of which is traceable to the Kenyan *energy standards* maintained by KEBS; or
 - (2) for installations involving *voltage* and/or *current transformer connected meters*, performing the appropriate next scheduled maintenance test in accordance with clause 4.3.14; or

(3) by installing *metering equipment* of similar or higher accuracy class which has been specially calibrated prior to conducting the field test using equipment whose current calibration is traceable to the Kenyan *energy* standards maintained by KEBS.

(b) *Metering equipment*,

(1) other than for half hour *metering*, tested under clause 4.8.2(a)(1) and 4.8.2(a)(2) shall be compliant with the requirements of the *Grid Code* if:

(i) the maximum errors for electrical installations with a *demand* equal to or less than 1 MW do not exceed 2.5%; or

(ii) the maximum errors for electrical installations with a *demand* greater than 1 MW do not exceed 1.5% for *active energy* measurements and 3% for *reactive energy* measurements.

(2) other than for half hour *metering*, tested under clause 4.8.2(a)(3) shall be compliant with the requirements of the *Grid Code* if the percentage discrepancy between the readings of the two meters does not exceed the aggregate of the nominal error classes of the two meters.

(3) for half hour *metering* tested under clause 4.8.2(a) shall comply with the standards of accuracy for *metering installations* at *approved connection points* determined in accordance with Chapter 7 of the *Grid Code*.

(c) Unless otherwise agreed by the *consumer* and the *distribution network service provider*, installed *active energy meters* shall be tested at three currents as follows:

(1) if the installed *active energy meter* is nominally compliant with KS IEC 61036 or AS 1284-1, testing shall be carried out at 100% and 10% of *basic current*, *unity power factor* and 100% of *basic current*, *0.5 power factor*; or

(2) if the installed *active energy meter* is nominally compliant with KS IEC 61036 or AS 1284-1, testing shall be carried out at 100% and 10% of rated current, *unity power factor* and 100% of rated current, *0.5 power factor*.

(d) If a test carried out under clause 4.3.13 requires the injection of current, then the *distribution network service provider* shall inspect the records stored in the *metering equipment* and adjust the electricity bill subsequently rendered to the relevant *consumer* to ensure that no amount is payable by the relevant *consumer* in respect of electricity consumed during the test. If a test carried out under clause 4.3.13 is based on actual *consumer loads*, then no adjustment is required under this clause.

(e) If a test of a meter (whether conducted at the request of the *consumer* or not) is found to overstate consumption by more than the tolerances specified in clause 4.8.2(b)(1), the *public electricity supplier* shall make appropriate adjustments in the *consumer's* favour to the *consumer's* electricity account.

4.8.3 Costs of field testing

(a) Subject to clause 4.8.3(b), costs incurred by a *distribution network service provider* testing *metering equipment* under clause 4.3.13, including the cost of replacing any seal used to protect the *metering equipment* broken by the *distribution network service provider* to allow the test to be carried out, are to be borne:

(1) by the *consumer* in accordance with a pricing order determined by the *Commission*, if the test is requested by the *consumer* and demonstrates that the *metering equipment* is not *defective*; and

- (2) otherwise, by the *distribution network service provider*.
- (b) For tests conducted following a request from a *consumer*, the *distribution network service provider* may seek payment of the anticipated costs of testing *metering equipment* prior to the commencement of testing, but if the *metering equipment* fails to meet the accuracy standards prescribed under clause 4.8.2(b)(1) then the *distribution network service provider* shall refund the payment made by the *consumer* within five *business days* of completion of the test.

4.8.4 Field testing procedures

- (a) A *distribution network service provider* shall give a *consumer* 5 *business days* notice (or such lesser period nominated by the *consumer*) of when and where a test of *metering equipment* under clause 4.8.1 is to be carried out and what method of testing under clause 4.8.2(a) is to be adopted.
- (b) A *consumer* is entitled to be present when a test of *metering equipment* is carried out under clause 4.8.1.
- (c) If the requirement under clause 4.8.1 that testing be carried out within 15 *business days* of receiving a request from a *consumer* would prevent the *consumer* from being present when the test is carried out, then the *distribution network service provider* and the *consumer* may agree a mutually convenient time to conduct the test.
- (d) The *distribution network service provider* shall keep records of tests under clause 4.8.1 for a minimum of 7 years.
- (e) The *distribution network service provider* shall provide copies of the results from any testing of *metering equipment* to the *consumer* on request.

4.9 MAINTENANCE TESTING

4.9.1 Maintenance plan

A *distribution network service provider* shall establish a maintenance plan for *metering equipment* which shall be approved by the *Commission*. The maintenance plan shall take account of the size of the *consumer load* metered, the age of the installed meters and the quantity and distribution of the installed meters.

4.9.2 CT metered electrical installations

- (a) Where a *current transformer* is used to meter a *consumer's* electrical installation which has a *load* greater than 1 MW, a meter accuracy test shall be conducted at greater than 10% of the nominal full meter *load* at least once in every 12 month period, and a full range meter accuracy test by a current injection method shall be conducted at least once in every two year period.
- (b) Where a *current transformer* is used to meter a *consumer's* electrical installation which has a *load* up to and including 1 MW, a meter accuracy test shall be conducted at greater than 10% of the nominal full meter *load* at least once in every three year period, and a full range meter accuracy test by a current injection method shall be conducted at least once in every six year period.

4.9.3 Direct metered electrical installations

- (a) For direct metered electrical installations a *distribution network service provider* shall categorise all relevant *metering equipment* into classes consisting of meters of the same year of manufacture and common design.
- (b) A *distribution network service provider* shall:

- (1) establish and maintain a sampling plan to ensure that each class of *metering equipment* is tested at least once in the first 15 years following manufacture, and at least once in each subsequent five year period.
 - (2) ensure that the sample testing contemplated in 4.9.3(b)(1) is conducted as an additional requirement to installation testing under clause 4.3.10.
- (c) If the test results from a sampling plan show that more than 70% of a class of meters has errors greater than 2% then the *distribution network service provider* shall replace or recalibrate all meters in that class.

4.10 DEFECTIVE METERING EQUIPMENT

4.10.1 Repair or replace

If a test under clause 4.3.13 or 4.3.14 demonstrates that any *metering equipment* is *defective*, the *distribution network service provider* shall:

- (a) repair the *metering equipment* so that it meets the minimum standard of accuracy which it was designed to meet; or
- (b) replace the *metering equipment* by installing *new metering equipment*.

4.10.2 Substitute readings

If a test under clause 4.3.13 or 4.3.14 demonstrates that *metering equipment* provided in relation to the *supply* of electricity to a *consumer* is *defective* then billing will proceed on the basis specified in this Chapter 4.

4.10.3 Cost of repair or replacement

Subject to clause 4.3.1(b), the cost of repairing *metering equipment* is to be borne by the *distribution network service provider* and the cost of replacing *metering equipment* is to be borne as contemplated in clause 4.3.5.

4.11 OBLIGATIONS IN RESPECT OF METERING DATA

4.11.1 Access

- (a) A *consumer* is entitled to access to data stored in *metering equipment* used to measure and record the amount of electricity supplied to his electrical installation, either by inspecting the *metering equipment* or, where available, by electronic access to the *metering equipment*, provided that the *consumer* shall not be able to access the *metering* software.
- (b) A *distribution network service provider* who provides to a *consumer* access to data stored in *metering equipment* by remote electronic means may charge the *consumer* the reasonable cost incurred by the latter as a result of that access.
- (c) Where a *distribution network service provider* has provided *facilities* to enable a *consumer* to electronically access data stored in *metering equipment*, if remote electronic access to *metering equipment* is unavailable for a period of five consecutive *business days* due to the actions within the control of the *distribution network service provider*, the *distribution network service provider* shall, if requested by the *consumer*, obtain data locally from the *metering equipment* and provide that data to the *consumer* at the *distribution network service provider's* cost.

4.11.2 Storage

A *distribution network service provider* shall store *metering data* in respect of separate *metering equipment* separately :

- (a) for 12 months in accessible format; and
- (b) for 6 years in archive, in the form in which it was collected under clause 4.7.2.

4.11.3 Confidentiality

- (a) A *distribution network service provider* or a *public electricity supplier* shall keep *metering data* confidential and use reasonable endeavours to protect and preserve the confidential nature of the *metering data*.
- (b) A *distribution network service provider* or a *public electricity supplier*:
 - (1) shall not disclose a *consumer's metering data* to any person except as permitted by the *Grid Code*;
 - (2) shall only use or reproduce a *consumer's metering data* for the purpose for which it was collected under the *Grid Code* or another purpose contemplated by any other code; and
 - (3) shall not permit *unauthorised persons* to have access to a *consumer's metering data*.
- (c) This clause 4.11.3 does not prevent:
 - (1) the disclosure, use or reproduction of *metering data* if the *metering data* is at the time generally and publicly available otherwise than as a result of breach of confidence by a *distribution network service provider* or a *public electricity supplier*;
 - (2) the disclosure of *metering data* by a *distribution network service provider* or a *public electricity supplier*:
 - (i) his *agents*, employees or the employees of his related bodies corporate; or
 - (ii) his legal or other professional adviser, auditor or other consultant, requiring the *metering data* for the purposes of the *Grid Code* or any other code or for the purpose of advising the *distribution network service provider* or a *public electricity supplier* (as the case may be) in relation to those purposes;
 - (3) the disclosure, use or reproduction of *metering data* with the explicit informed consent of the relevant *consumer*;
 - (4) the disclosure, use or reproduction of *metering data* to the extent required by law or by lawful requirement of:
 - (i) any government or governmental body, authority or agency having jurisdiction over a *distribution network service provider* or a *public electricity supplier* or his related bodies corporate;
 - (ii) any stock exchange having jurisdiction over a *distribution network service provider* or a *public electricity supplier* or his related bodies corporate; or
 - (iii) the *Commission*;
 - (iv) the disclosure, use or reproduction of *metering data* required in connection with legal proceedings, arbitration, expert determination or other dispute resolution mechanism under the *Grid Code* or any other code or legislation;
 - (v) the disclosure, use or reproduction of *metering data* required to protect the safety of personnel or equipment; or
 - (vi) the disclosure, use or reproduction of *metering data* by or on behalf of a *distribution network service provider* or a *public electricity supplier* to the

extent reasonably required in connection with that *distribution network service provider's* or *public electricity supplier's* financing arrangements, investment in that *distribution network service provider* or *public electricity supplier* or a disposal of that *distribution network service provider's* or *public electricity supplier's* assets.

- (d) In the case of a disclosure under clauses 4.11.3(c)(2) or (3), the *distribution network service provider* or *public electricity supplier* making the disclosure shall inform the relevant person to whom the information is disclosed of the confidentiality of the *metering data* and use reasonable endeavours to ensure that that person keeps the *metering data* confidential.

4.11.4 Ownership of metering data

Metering data collected by a *distribution network service provider* or a *public electricity supplier* or an *agent* of the *distribution network service provider* or *public electricity supplier* is the property of the *distribution network service provider* or *public electricity supplier*.

SCHEDULES TO CHAPTER 4

TABLE OF CONTENTS

| | Page |
|--|------|
| SCHEDULE 4.1 | |
| TYPICAL BULK METERING SYSTEM | 125 |
| SCHEDULE 4.2 | |
| TYPES AND ACCURACY OF METERING INSTALLATIONS | 126 |
| SCHEDULE 4.3 | |
| INSPECTION AND TESTING REQUIREMENTS | 130 |
| SCHEDULE 4.4 | |
| METERING PROVIDERS | 132 |
| SCHEDULE 4.5 | |
| METERING REGISTER | 135 |
| SCHEDULE 4.6 | |
| NEW RETAIL METERING, SWITCHING AND TIME KEEPING EQUIPMENT | 137 |

SCHEDULE 4.1

TYPICAL BULK METERING SYSTEM

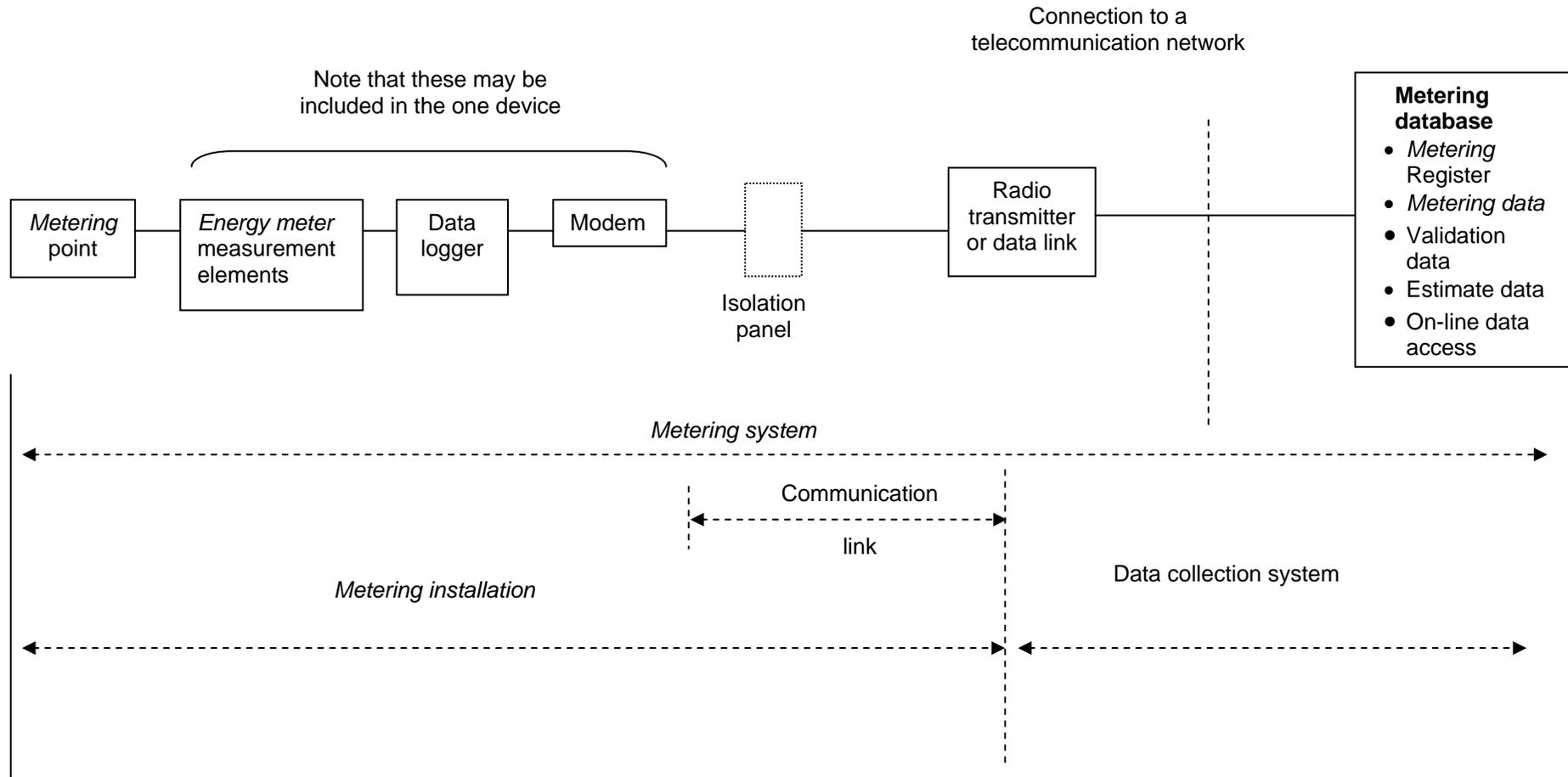

SCHEDULE 4.2**TYPES AND ACCURACY OF METERING INSTALLATIONS****S4.2.1 GENERAL REQUIREMENTS**

- (a) The following are the minimum requirements for *metering installations*.
- (b) *Code Participants* may install a *metering installation* of a higher level accuracy, with the full costs of this work being met by that *Code Participant*.

S4.2.2 METERING INSTALLATIONS COMMISSIONED PRIOR TO COMMENCEMENT DATE

- (a) The use of *metering* class *current transformers* and *voltage transformers* that are not in accordance with Table 1 of clause 3 (schedule 4.2) are permitted provided that where necessary to achieve the overall accuracy requirements:
- (1) meters of a higher class accuracy are installed; and/or
 - (2) calibration factors are applied within the meter to compensate for *current transformer* and *voltage transformer* errors.
- (b) Protection *current transformers* are acceptable where there are no suitable *metering* class *current transformers* available and the overall accuracy and performance levels can be met.
- (c) Where the requirements of clause 2(a) (schedule 4.2) and clause 2(b) (schedule 4.2) cannot be achieved then the responsible person is required to comply with transitional arrangements or obtain an exemption from the *Commission* or upgrade the *metering installation* to comply with this schedule 4.2.
- (d) The arrangements referred to in clause 2(c) (schedule 4.2) may remain in force while the required accuracy and performance can be maintained within the requirements of the *Grid Code*.
- (e) The purchase of new *current transformers* and *voltage transformers* shall comply with the *Grid Code*.

S4.2.3 ACCURACY REQUIREMENTS FOR METERING INSTALLATIONSTable 1: Overall accuracy requirements of *metering installation* equipment

| Type | Energy (GWhr pa) per <i>metering</i> point | Maximum allowable overall error ($\pm\%$) (refer Tables 2-4) at full load | | Minimum acceptable class of components | Meter clock error (seconds) in reference to EAST |
|------|--|---|----------|---|--|
| | | active | reactive | | |
| 1 | > 100 | 0.5 | 1.0 | 0.2 CT/VT/Meter Wh 0.5 Meter varh | ± 5 |
| 2 | 10 - 100 | 1.0 | 2.0 | 0.5 CT/VT Meter Wh 1.0 Meter varh | ± 7 |
| 3 | 0.10 - 10 | 1.5 | 3.0 | 0.5 CT/VT 1.0 Meter Wh 2.0 Meter varh | ± 10 |
| 4 | <0.10 | 1.5 | NA | 0.5 CT 1.0 Meter Wh | ± 20 |

Notes:

1. For Type 3 and Type 4 installation, it is acceptable to use direct *connected* meters meeting the relevant requirements of KS IEC 61036 or AS 1284-1 for "Electricity Metering – General Purpose Watthour Meters". The *metering equipment* shall comply with any applicable specifications or guidelines (including any transitional arrangements) specified by KEBS.
2. *High Voltage consumers* that require a VT and whose annual consumption is below 750 MWh, shall meet the relevant accuracy requirements of Type 3 *metering* for *active energy* only.

Table 2: Type 1 installation - annual *energy* throughput greater than 100 GWhr

| % Rated load | <i>Power factor</i> | | | | | |
|--------------|---------------------|---------------|----------|-------------|----------|----------|
| | Unity | 0.866 lagging | | 0.5 lagging | | Zero |
| | active | active | reactive | active | reactive | reactive |
| 10 | 0.7% | 0.7% | 1.4% | n/a | n/a | 1.4% |
| 50 | 0.5% | 0.5% | 1.0% | 0.5% | 1.0% | 1.0% |
| 100 | 0.5% | 0.5% | 1.0% | n/a | n/a | 1.0% |

Table 3: Type 2 installation - annual *energy* throughput between 10 and 100 GWhr

| % Rated load | <i>Power factor</i> | | | | | |
|--------------|---------------------|---------------|----------|-------------|----------|----------|
| | Unity | 0.866 lagging | | 0.5 lagging | | Zero |
| | active | active | reactive | active | reactive | reactive |
| 10 | 1.4% | 1.4% | 2.8% | n/a | n/a | 2.8% |
| 50 | 1.0% | 1.0% | 2.0% | 1.0% | 2.0% | 2.0% |
| 100 | 1.0% | 1.0% | 2.0% | n/a | n/a | 2.0% |

Table 4: Type 3 installation - annual *energy* throughput from 0.10 GWhr to 10 GWhr

| % Rated load | <i>Power factor</i> | | | | | |
|--------------|---------------------|---------------|----------|-------------|----------|----------|
| | Unity | 0.866 lagging | | 0.5 lagging | | Zero |
| | active | active | reactive | active | reactive | reactive |
| 10 | 2.0% | 2.0% | 4.0% | n/a | n/a | 4.0% |
| 50 | 1.5% | 1.5% | 3.0% | 1.5% | 3.0% | 3.0% |
| 100 | 1.5% | 1.5% | 3.0% | n/a | n/a | 3.0% |

Table 5: Type 4 installation - annual *energy* throughput less than 0.10 GWhr *Power factor*

| % Rated load | <i>Power factor</i> | | |
|--------------|---------------------|---------------|-------------|
| | Unity | 0.866 lagging | 0.5 lagging |
| 10 | 2.0% | 2.0% | n/a |
| 50 | 1.5% | 1.5% | 1.5% |
| 100 | 1.5% | 1.5% | n/a |

(NOTE: All measurements in Tables 2 to 5 are to be referred to 25 degrees Celsius).

(a) The method for calculating the overall error is the vector sum of the errors of each component part, i.e. $a + b + c$, where:

a = the error of the *voltage transformer* and wiring

b = the error of the *current transformer* and wiring

c = the error of the Meter.

(b) If compensation is carried out then the resultant *metering system* error shall be as close as practicable to zero.

S4.2.4 CHECK METERING

(a) *Check metering* is to be applied in accordance with the following Table:

| Type | <i>Energy</i> (GWhr pa) per <i>metering</i> point | <i>Check metering</i> requirements |
|------|---|------------------------------------|
| 1 | greater than 100 | <i>Check metering installation</i> |
| 2 | 10 to 100 | <i>Partial check metering</i> |
| 3 | 0.10 to 10 | No requirement |
| 4 | less than 0.10 | No requirement |

(b) A *check metering installation* involves the provision of a separate *metering installation* using separate *current transformer* cores and separately fused *voltage transformer* secondary circuits, preferably from separate secondary windings.

(c) Where the *check metering installation* duplicates the revenue *metering installation* and accuracy level, the average of the two validated data sets may be used to determine the *energy* measurement.

(d) *Partial check metering* involves the use of other *metering data* or operational data available in 30 min electronic format.

(e) The physical arrangement of *partial check metering* shall be agreed between the responsible person and the relevant *Code Participant*.

(f) *Check metering installations* may be supplied from secondary circuits used for other purposes and may have a lower level of accuracy than the revenue *metering installation*, but shall not exceed twice the level prescribed for the revenue *metering installation*.

S4.2.5 RESOLUTION AND ACCURACY OF DISPLAYED OR CAPTURED DATA

Any programmable settings available within a *metering installation*, *data logger* or any peripheral device, which may affect the resolution of displayed or stored data, shall meet the relevant requirements of **IEC 1036** and shall comply with any applicable specifications or guidelines (including any transitional agreements) specified by KEBS.

S4.2.6 GENERAL DESIGN STANDARDS

S4.2.6.1 Design requirements

Without limiting the scope of detailed design, the following requirements shall be incorporated in the design of each *metering installation*:

- (a) For *metering installations* greater than 100 GWhr pa per *metering* point, the *current transformer* core and secondary wiring associated with the revenue meter, shall not be used for any other purpose unless otherwise agreed by the *Commission*.
- (b) For *metering installations* less than 100 GWhr pa per *metering* point the *current transformer* core and secondary wiring associated with the revenue meter may be used for other purposes (e.g. local *metering* or protection) provided the responsible person shall demonstrate to the satisfaction of the *Code Participant* with whom he has a *connection agreement* that the accuracy of the *metering installation* is not compromised and suitable procedures/measures are in place to protect the security of the *metering installation*.
- (c) Where a *voltage transformer* is required, if separate secondary windings are not provided, then the *voltage supply* to each *metering installation* shall be separately fused and located in an accessible position as near as practical to the *voltage transformer* secondary winding.
- (d) Secondary wiring shall be by the most direct route and the number of terminations and links shall be kept to a minimum.
- (e) The incidence and magnitude of burden *changes* on any secondary winding *supplying* the *metering installation* shall be kept a minimum.
- (f) Meters shall meet the relevant requirements of **IEC 1036** and shall also comply with any applicable specifications or guidelines (including any transitional arrangements) specified by the KEBS.
- (g) New *instrument transformers* shall meet the relevant requirements of IEC 60044-2, and in particular IEC 60044-1 for *current transformers* and IEC 60186 for *voltage transformers* and shall also comply with any applicable specifications or guidelines (including any transitional arrangements) specified by KEBS.
- (h) Suitable isolation *facilities* are to be provided to facilitate testing and calibration of the *metering installation*.
- (i) Suitable drawings and supporting information, detailing the *metering installation*, shall be available for maintenance and auditing purposes.

S4.2.6.2 Design guidelines

In addition to the above design requirements, the following guidelines should be considered for each *metering installation*:

- (a) The provision of separate secondary windings for each *metering installation* where a *voltage transformer* is required.
- (b) A *voltage* changeover scheme where more than one *voltage transformer* is available.

SCHEDULE 4.3**INSPECTION AND TESTING REQUIREMENTS****S4.3.1 GENERAL**

(a) The responsible person shall ensure that *metering equipment* purchased has *Commission* type approval following testing by an accredited laboratory recognised under the International Certification Scheme in accordance with specifications or guidelines (including transitional arrangements) specified by **KEBS**. The responsible person shall provide the relevant approval certificates to the *Commission* on request.

(b) The responsible person shall ensure that equipment comprised in a *metering installation* purchased has been tested to the required class accuracy with less than the following uncertainties:

| | | |
|-----------------------|---|----------------|
| Class 0.2 CT/VT | - | +/-0.05 % |
| Class 0.2 Wh meters | - | +/-0.05/cosØ % |
| Class 0.5 CT/VT | - | +/-0.1 % |
| Class 0.5 Wh meters | - | +/-0.1/cosØ % |
| Class 0.5 varh meters | - | +/-0.2/sinØ % |
| Class 1.0 Wh meters | - | +/-0.2/cosØ % |
| Class 1.0 varh meters | - | +/-0.3/sinØ % |
| Class 2.0 varh meters | - | +/-0.4/sinØ % |

Appropriate test certificates are to be kept by the equipment owner.

(c) The responsible person shall ensure that testing of the *metering installation* is carried out:

- (1) in accordance with this schedule 4.3, or
- (2) in accordance with an *asset* management strategy that defines an alternative testing practice (.i.e. other than time-based) determined by the responsible person and approved by the *Commission*;
- (3) in accordance with a test plan which has been registered with the *Commission*; and
- (4) to the same requirements as for new equipment where equipment is to be recycled for use in another site.

(d) Other affected parties may witness the tests on request to the responsible person.

(e) The *Commission* shall review the prescribed testing requirements in this schedule 4.3 every 5 years in accordance with equipment performance and industry standards.

(f) The responsible person shall:

- (1) provide the test results to the *Commission*;
- (2) advise each affected *public electricity supplier* and *electric power producer* of the outcome of the tests; and
- (3) provide the results of the test to each affected *Code Participant* on request.

- (g) The testing intervals may be increased if the equipment type/experience proves favourable.

Table 1: Maximum allowable level of testing uncertainty (+/-)

| Description | | <i>Metering installation type</i> | | | |
|---------------|-----------------|-----------------------------------|------------|------------|------------|
| | | Type 1 | Type 2 | Type 3 | Type 4 |
| In laboratory | CTs/VTs | 0.05% | 0.1% | 0.1% | 0.1% |
| | Meters Whs | 0.05/cosØ % | 0.1/cosØ % | 0.2/cosØ % | 0.2/cosØ % |
| | Meters varhs | 0.2/sinØ % | 0.3/sinØ % | 0.4/sinØ % | |
| In field | CTs/VTs | 0.1% | 0.2% | 0.2% | 0.2% |
| | Meters Whs | 0.1/cosØ % | 0.2/cosØ % | 0.3/cosØ % | 0.3/cosØ % |
| | Meters varhs | 0.3/sinØ % | 0.4/sinØ % | 0.5/sinØ % | |

Table 2: Maximum period between tests

| Description | <i>Metering installation type</i> | | | |
|---|--|-----------|----------|----------|
| | Type 1 | Type 2 | Type 3 | Type 4 |
| CT | 10 years | 10 years | 10 years | 10 years |
| VT | 10 years | 10 years | 10 years | |
| Burden tests | When meters are tested or when <i>changes</i> are made. | | | |
| CT <i>connected</i> meter (electronic) | 5 years | 5 years | 5 years | 5 years |
| CT <i>connected</i> meter (induction) | 2.5 years | 2.5 years | 5 years | 5 years |
| Direct <i>connected</i> meter | The testing and inspection requirements shall be by an <i>asset</i> management strategy determined at the time that market expansion occurs. | | | |

Table 3: Period between inspections

| Description | <i>Metering installation type</i> | | | |
|---|---|--|---|--------------------------|
| | Type 1 | Type 2 | Type 3 | Type 4 |
| <i>Metering installation</i> equipment inspection | 2.5 years Note: increased inspection period allowed because of <i>check metering</i> <i>installation</i> requirements. | 12 months (2.5 years if <i>check</i> <i>metering</i> installed) | > 10 GWhr: 2 years 2 < <10 GWhr: 3 years <2 GWhr: when meter is tested. | When meter is tested. |

S4.3.2 NOTES - TECHNICAL GUIDELINES

- (a) *Current transformer* and *voltage transformer* tests are primary injection tests or other testing procedures as approved by the *Commission*.
- (b) All reference or calibration equipment shall be tested to ensure full traceability to Kenyan national measurement standards.
- (c) The calculations of accuracy based on test results, are to include all reference standard errors.
- (d) An "estimate of testing uncertainties" shall be calculated in accordance with the ISO "Guide to the Expression of Uncertainty for Measurement".
- (e) Where operational *metering* is associated with settlements *metering* then a shorter period between inspections is recommended.
- (f) For $\sin\theta$ and $\cos\theta$ refer to the ISO "Guide to the Expression of Uncertainty in Measurement", where $\cos\theta$ is the *power factor*.
- (g) A typical inspection may include: check the seals, compare the pulse counts, compare the direct readings of meters, verify meter parameters and physical *connections*, *current transformer* ratios by comparison.

SCHEDULE 4.4

METERING PROVIDERS

S4.4.1 GENERAL

- (a) A *Metering* Provider shall be registered with the *Commission*, and only for the type of work the *Metering* Provider is qualified to provide.
- (b) The *Commission* shall establish a qualification process for a *Metering* Provider that enables registration to be achieved in accordance with the requirements of this schedule 4.4.
- (c) The qualification process specified in clause 1(b) (schedule 4.4) shall include an agreement between the *Commission* and the *Metering* Provider which ensures that **the *Metering* Provider accepts all relevant responsibilities of the *Code*.**
- (d) The *Metering* Provider shall have the necessary licences in accordance with applicable Kenyan requirements.
- (e) The *Metering* Provider shall ensure that any *metering equipment* they install is suitable for the range of operating conditions to which it will be exposed (e.g. temperature; impulse levels), and operates within the defined limits for that equipment.

S4.4.2 CATEGORIES OF REGISTRATION

(a) Registrations shall be categorised as follows or according to other procedures approved by the *Commission*:

Table 1

| Category | Competency |
|----------|--|
| 1C | Class 0.2 CTs with < 0.1% uncertainty. |
| 1V | Class 0.2 VTs with < 0.1% uncertainty. |
| 1M | Class 0.2 Wh meters with < $0.1/\cos\theta$ % uncertainty and class 0.5 varh meters with < $0.3/\sin\theta$ % uncertainty. |
| 1A | Class 0.2 CTs, VTs, Wh meters; class 0.5 varh meters; the total installation to 0.5%. Whs with < 0.2% uncertainty at unity <i>power factor</i> ; 1.0% for varhs with < 0.4% uncertainty at zero <i>power factor</i> . |
| 2C | Class 0.5 CTs with < 0.2% uncertainty. |
| 2V | Class 0.5 VTs with < 0.2% uncertainty. |
| 2M | Class 0.5 Wh meters with < $0.2/\cos\theta$ % uncertainty and class 1.0 varh meters with < $0.4/\sin\theta$ % uncertainty. |
| 2A | Class 0.5 CTs, VTs, Wh meters; class 1.0 varh meters; the total installation to 1.0%. Whs with < 0.4% uncertainty at unity <i>power factor</i> ; 2.0% for varhs with < 0.5% uncertainty at zero <i>power factor</i> . |

Table 2

| Category | Competency |
|----------|---|
| 3M | Class 1.0 Wh meters with < $0.3/\cos\theta$ % uncertainty and class 2.0 varh meters with < $0.5/\sin\theta$ % uncertainty. |
| 3A | Class 0.5 CTs, VTs; class 1.0 Wh meters; class 2.0% varh meters; the total installation to 1.5%. Whs with < 0.5% uncertainty at unity <i>power factor</i> ; 3.0% for varhs with < 0.6% uncertainty at zero <i>power factor</i> . |
| 4M | Class 1.0 Wh meters and class 1.5 Wh meters with < $0.3/\cos\theta$ % uncertainty. |

Table 3

| Category | Competency |
|----------|---|
| L | Approved <i>communication link</i> installer. |

S4.4.3 CAPABILITIES OF METERING PROVIDERS

Category 1A, 2A, 3A and 4M *Metering providers* shall be able to exhibit the following capabilities to the reasonable satisfaction of the *Commission*:

(a) Detailed design and specification of *metering* schemes, including:

- (1) knowledge and understanding of this Chapter 4;
 - (2) knowledge of equipment (meters, *current transformers* and where applicable *voltage transformers*);
 - (3) design experience including knowledge of *current transformers* and where applicable *voltage transformers* and the effect of burdens on performance;
 - (4) ability to calculate summation scheme values, multipliers, etc; and
 - (5) ability to produce documentation, such as single line diagrams, panel layouts and wiring diagrams.
- (b) Programming and certification requirements for *metering installations* to the required accuracy, including:
- (1) licensed access to *metering* software applicable to all equipment being installed by the *Metering Provider*;
 - (2) ability to program requirements by setting variables in meters, summators, modems, etc;
 - (3) management of the testing of all equipment to the accuracy requirements specified in this Chapter 4;
 - (4) certifications that all calibration and other meter parameters have been set, verified and recorded prior to meters, *data loggers*, etc., being released for installation;
 - (5) all reference/calibration equipment to be tested to ensure full traceability to *Kenyan Standards* through *verifying authorities* or directly from KEBS; and
 - (6) compliance with ISO/IEC Guide 25 “General Requirements for the Competence of Calibration and Testing Laboratories” with regard to the calculation of uncertainties and accuracy.
- (c) Installation and commissioning of *metering installations* including the remote accessing of data, including:
- (1) the use of calibrated test equipment to perform primary injection tests and field accuracy tests;
 - (2) the availability of trained and competent staff to install and test *metering installations* to determine that installation is correct; and
 - (3) the use of test procedures to confirm that the *metering installation* is correct and that *metering* constants are recorded and/or programmed correctly.
- (d) Inspection and maintenance of *metering installations* and equipment, including:
- (1) regular readings of the measurement device where external *data loggers* or recorders to be used (6 monthly) and verification with the records of the *Code Participant* with whom he has a *connection agreement*;
 - (2) approved test and inspection procedures to perform appropriate tests as detailed in this Chapter 4;
 - (3) calibrated field test equipment for primary injection and meter testing to the required levels of uncertainty; and
 - (4) secure documentation system to maintain *metering* records for all work performed on a *metering installation*, including details of the security method used.

- (e) Verification of revenue *metering data* and *check metering data*, as follows:
- (1) on commissioning *metering data*, verification of all readings, *constraints* (adjustments) and multipliers to be used for converting raw data to consumption data; and
 - (2) on inspection, testing and/or maintenance, verification that readings, constants and multipliers are correct by direct conversion of meter readings and check against the *metering database*.
- (f) Quality System as 9000 series standards, including:
- (1) a quality system to KS ISO 9000 series applicable to the work to be performed:-
 - Type 1 full implementation of KS ISO 9002;
 - Type 2 full implementation of KS ISO 9002;
 - Type 3 implementation of KS ISO 9002 to a level agreed with the *Commission*;
 - Type 4 implementation of KS ISO 9002 to a level agreed with the *Commission* during the first 2 years after the commencement date, this quality system requirement will be deemed to be met if an applicant has commenced KS ISO 9002 implementation and achieves the required level by 2 years after the commencement date;
 - (2) the calculations of accuracy based on test results, are to include all reference standard errors;
 - (3) an estimate of Testing Uncertainties which shall be calculated in accordance with the KS ISO "Guide to the Expression of Uncertainty in Measurement"; and
 - (4) a knowledge and understanding of the appropriate standards and guides, including those in the *Code*.

SCHEDULE 4.5 - METERING REGISTER

S4.5.1 GENERAL

- (a) The *metering* register forms part of the *metering database* and holds static *metering* information associated with *metering installations* defined by the *Code* that determines the validity and accuracy of *metering data*.
- (b) The purpose of the *metering* register is to facilitate:
 - (1) the registration of *connection points*, *metering* points and affected *Code Participants*;
 - (2) the verification of compliance with the *Code*; and
 - (3) the auditable control of *changes* to the registered information.
- (c) The data in the *metering* register is to be regarded as confidential and only suitable data would be released to the appropriate party.

S4.5.2 METERING REGISTER INFORMATION

Metering information to be contained in the *metering* register should include, but is not limited to the following:

- (a) *Connection* and *metering* point reference details, including:
 - (1) agreed locations and reference details (e.g. drawing numbers);
 - (2) loss compensation calculation details;

- (3) site identification names;
 - (4) details of *public electricity suppliers, electric power producers* and *network service providers* associated with the *connection point*; and
 - (5) nomination of the responsible person.
- (b) The identity and characteristics of *metering equipment* (i.e. *instrument transformers, revenue metering installation* and *check metering installation*), including:
- (1) serial numbers;
 - (2) *metering installation* identification name;
 - (3) *metering installation* types and models;
 - (4) instrument transformer ratios (available and *connected*);
 - (5) current test and calibration programme details, test results and references to test certificates;
 - (6) *asset* management plan and testing schedule;
 - (7) calibration tables, where applied to achieve *metering installation* accuracy;
 - (8) *Metering Provider(s)* details;
 - (9) summation scheme values and multipliers; and
 - (10) data register coding details.
- (c) Data communication details, including:
- (1) telephone number(s) for access to data;
 - (2) communication equipment type and serial numbers;
 - (3) communication protocol details or references;
 - (4) data conversion details;
 - (5) user identifications and access rights; and
 - (6) 'write' password (to be contained in a hidden or protected field).
- (d) Data validation and substitution processes agreed between affected parties, including:
- (1) algorithms;
 - (2) data comparison techniques;
 - (3) processing and alarms (e.g. *voltage* source limits; phase-angle limits);
 - (4) *check metering* compensation details; and
 - (5) alternate data sources.
- (e) Data processing prior to the process of producing bills and credit notes, including algorithms for:
- (1) *generation* half-hourly 'sent-out' calculation;
 - (2) *consumer* half-hourly *load* calculation; and
 - (3) *public electricity supplier* net *load* calculation.

SCHEDULE 4.6 NEW RETAIL METERING, SWITCHING AND TIME KEEPING EQUIPMENT

S4.6.1 STANDARDS OF ACCURACY FOR NEW RETAIL METERING EQUIPMENT

- (a) The minimum standards of accuracy for *new metering equipment*, other than *half hour metering equipment* are as follows:
- (1) for installations with a *demand* equal to or less than 1 MW:
 - (i) the *active energy meter*: an induction *energy meter* complying with the relevant performance requirements of KS IEC 61036 or AS 1284-1, or a static *energy meter* complying with the performance requirements of KS IEC 61036 or AS 1284-1- accuracy class 1.0;
 - (ii) the *current transformer* (if applicable): a *current transformer* complying with IEC 60044-1- accuracy class 0.5;
 - (iii) the *voltage transformer* (if applicable): a *voltage transformer* complying with IEC 60186- accuracy class 0.5;
 - (iv) the *reactive energy meter* (if applicable): a *reactive energy meter* complying with the requirements of 9.11.1(a)(1)(i) when tested as an *energy meter* with a 90 degree phase shift of current with respect to *voltage*. The *reactive energy meter* may be combined within the same case as the *active energy meter* and may share common measurement and processing *facilities*;
 - (2) for installations with a *demand* greater than 1 MW:
 - (i) the *active energy meter*: an *energy meter* complying with the performance requirements of KS IEC 61036 or AS 1284-1 - accuracy class 0.5;
 - (ii) the *current transformer* (if applicable): a *current transformer* complying with IEC 60044-1 - accuracy class 0.5;
 - (iii) the *voltage transformer* (if applicable): a *voltage transformer* complying with IEC 60186 - accuracy class 0.5;
 - (iv) the *reactive energy meter* (if applicable): a *reactive energy meter* complying with the requirements of clause 9.11.1(a)(2)(i) when tested as an *energy meter* with a 90 degree phase shift of current with respect to *voltage*. The *reactive energy meter* may be combined within the same case as the *active energy meter* and may share common measurement and processing *facilities*; and
 - (3) for prepayment *metering installations*, a meter complying with the relevant performance requirements of **IEC 1036**, as appropriate.
- (b) The minimum standards of accuracy for *half hour metering equipment* are the standards for *metering installations* at *approved connection points* determined in accordance with Chapter 7 of the *Code*.

S4.6.2 SWITCHING AND TIME KEEPING

Where tariffs for the sale of electricity to a *consumer* in respect of an electrical installation are based on different rates according to the time of *day*, the *metering equipment* shall either:

- (1) include a clock complying with KS IEC 61036 or AS 1284-1; or
- (2) have a clock which is automatically adjusted on each occasion it is accessed electronically, and effectively remain within the time-keeping standards imposed by KS IEC 61036 or AS 1284-1.

CHAPTER 5 TRANSMISSION AND DISTRIBUTION NETWORK SYSTEMS

TABLE OF CONTENTS

| | Page |
|--|------|
| PART A - GENERAL | 141 |
| 5.1.SUMMARY OF KEY PRINCIPLES AND CORE OBJECTIVES OF NETWORK PRICING | 141 |
| PART B - GENERAL PRINCIPLES GOVERNING REGULATION OF TRANSMISSION REVENUE | 141 |
| 5.2 REGULATION OF TRANSMISSION REVENUE REQUIREMENT | 141 |
| 5.2.1 Introduction | 141 |
| 5.2.2 Objectives of the transmission revenue regulatory regime to be administered by the Commission | 141 |
| 5.2.3 Principles for regulation of transmission aggregate revenue | 142 |
| 5.2.4 Form and mechanism of economic regulation | 144 |
| 5.2.5 Information disclosure by Transmission Network Service Provider | 145 |
| PART C - TRANSMISSION PRICING | 146 |
| 5.3 TRANSMISSION NETWORK SERVICE PROVIDER PRUDENT REQUIREMENTS | 146 |
| 5.3.1 Prudent requirements for network service | 146 |
| 5.3.2 Capital contribution or prepayment for a specific asset | 146 |
| 5.3.3 Treatment of past capital contributions | 146 |
| 5.4 BILLING AND SETTLEMENTS PROCESS | 147 |
| 5.4.1 Billing for transmission service | 147 |
| 5.4.2 Minimum information to be provided in network service bills | 147 |
| 5.4.3 Obligation to pay | 147 |
| PART D - NETWORK PRICING FOR DISTRIBUTION SYSTEMS | 147 |
| 5.5 GENERAL REGULATION OF DISTRIBUTION NETWORK PRICING | 147 |
| 5.5.1 Guidelines for distribution service pricing | 147 |
| 5.5.2 Objectives of distribution service pricing | 148 |
| 5.5.3 Principles for regulation of distribution service pricing | 148 |
| 5.5.4 Economic regulation of distribution services | 150 |
| 5.5.5 Form and mechanism of economic regulation | 151 |
| 5.5.6 Monitoring of Distribution Network Owner performance and compliance with regulatory determinations | 152 |
| 5.5.7 Information disclosure by the Commission | 153 |
| PART E - DISTRIBUTION NETWORK PRICING | 155 |

| | |
|---|-----|
| 5.6 DISTRIBUTION NETWORK SERVICE PROVIDER PRUDENT REQUIREMENTS | 155 |
| 5.6.1 Prudent requirements for distribution network service | 155 |
| 5.6.2 Capital contributions, pre-payments and financial guarantees | 155 |
| 5.6.3 Treatment of past pre-payments and capital contributions | 156 |
| 5.7 BILLING AND SETTLEMENTS PROCESS | 156 |
| 5.7.1 Billing for distribution network services | 156 |
| 5.7.2 Minimum information to be provided in distribution network service bills | 157 |
| 5.7.3 Settlement between distribution network service providers | 157 |
| 5.7.4 Obligation to pay | 157 |
| 5.8 DISTRIBUTION NETWORKS SERVICE PRICING RECORDS | 157 |
| 5.9 DATA REQUIRED FOR DISTRIBUTION NETWORK SERVICE PRICING | 157 |
| 5.9.1 Forecast use of networks by Distribution Consumers and embedded electric power producers | 157 |
| 5.9.2 Confidentiality of distribution network pricing information | 157 |
| SCHEDULES TO CHAPTER 5 | 158 |

CHAPTER 5 TRANSMISSION AND DISTRIBUTION NETWORK SYSTEMS

PART A - GENERAL

5.1.SUMMARY OF KEY PRINCIPLES AND CORE OBJECTIVES OF NETWORK PRICING

- (a) Section 62 of the *Act* sets out the framework and process for regulating the prices that may be charged by electricity entities for the *supply* of electricity. Chapter 5 is to be read subject to and in accordance with that section of the *Act*.
- (b) This Chapter of the *Code* sets out the principles for the calculation of revenues for *network service providers* and the rules for the calculation of prices to be paid by *Network users* for the conveyance of electricity and the provision of related services using the Kenyan *network*.
- (c) The key principles underlying the *transmission* and *distribution* pricing provisions in this Chapter are intended to:
 - (1) promote competition in the provision of *network services* wherever practicable;
 - (2) facilitate a commercial environment which is transparent and stable, and which does not discriminate between *users* of *network services*; and
 - (3) regulate the non-competitive market for *network services* in a way which seeks the same outcomes as those achieved in competitive markets.
- (d) The core objectives intended to be achieved by the application of the *transmission* and *distribution* pricing provisions in this Chapter 5 are:
 - (1) efficiency in the use, operation, and maintenance of, and investment in, the *network*, and in the location of *generation* and demand;
 - (2) upstream and downstream competition;
 - (3) price stability; and
 - (4) equity.
- (e) The determination of the *network service* price and its application to a *network user* is independent of any contractual arrangement in respect of the purchase of *energy* which that *network user* has entered.

PART B - GENERAL PRINCIPLES GOVERNING REGULATION OF TRANSMISSION REVENUE

5.2 REGULATION OF TRANSMISSION REVENUE REQUIREMENT

5.2.1 Introduction

The *Code* does not limit or prescribe the methodologies to be applied by the *Commission* in exercising its regulatory powers under the *Act* except to the extent that those methodologies must be consistent with the objectives, principles, broad forms and mechanisms, and information disclosure requirements described in clauses 5.2.2 to 5.2.5 inclusive of the *Code*.

5.2.2 Objectives of the transmission revenue regulatory regime to be administered by the Commission

The *transmission* revenue regulatory regime to be administered by the *Commission* under the *Act* must seek to achieve the following objectives:

- (a) an efficient and cost-effective Regulatory environment;

- (b) an incentive-based Regulatory regime which:
- (1) provides an equitable allocation between *transmission network users* and *transmission network owners* and/or *transmission network service providers* (as appropriate) of efficiency gains reasonably expected by the *Commission* to be achievable by the *transmission network owners* and/or *transmission network service providers* (as appropriate); and
 - (2) provides for, on a prospective basis, a sustainable commercial revenue stream which includes a fair and reasonable rate of return to *transmission network owners* and/or *transmission network service providers* (as appropriate) on efficient investment, given efficient operating and maintenance practices of the *transmission network owners* and/or *transmission network service providers* (as appropriate);
- (c) prevention of monopoly rent extraction by *transmission network owners* and/or *transmission network service providers* (as appropriate);
- (d) an environment which fosters an efficient level of investment within the *transmission* sector, and upstream and downstream of the *transmission* sector;
- (e) an environment which fosters efficient operating and maintenance practices within the *transmission* sector;
- (f) an environment which fosters efficient use of existing infrastructure;
- (g) reasonable recognition of pre-existing policies of the Kenyan *government* regarding *transmission asset* values, revenue paths and prices;
- (h) promotion of competition in upstream and downstream markets and promotion of competition in the provision of *network services* where economically feasible;
- (i) reasonable regulatory accountability through transparency and public disclosure of regulatory processes and the basis of regulatory decisions;
- (j) reasonable certainty and consistency over time of the outcomes of regulatory processes, recognizing the adaptive capacities of *Code Participants* in the provision and use of *transmission network assets*; and
- (k) reasonable and well defined regulatory discretion which permits an acceptable balancing of the interests of *transmission network owners* and/or *transmission network service providers* (as appropriate), *transmission network users* and the public interest.

5.2.3 Principles for regulation of transmission aggregate revenue

The regime under which the revenues of *transmission network owners* and/or *transmission network service providers* (as appropriate) are to be regulated under the *Act* is to be administered by the *Commission* in accordance with the following principles:

- (a) Concerns over monopoly pricing in respect of the *transmission network* will, wherever possible and practicable, be addressed through the introduction of competition in the provision of *transmission services*.
- (b) Where pro-competitive and structural reforms alone are not a practicable or adequate means of addressing the problems of monopoly pricing in respect of the *transmission network* or protecting the interests of *transmission network users*, the form of economic regulation applied is to be revenue capping or rate of return.

- (c) The regulatory regime to be administered by the *Commission* must be consistent with the objectives outlined in clause 5.2.2 and must also have regard to the need to:
- (1) provide *transmission network owners* and/or *transmission network service providers* (as appropriate) with incentives and reasonable opportunities to increase efficiency;
 - (2) create an environment in which *generation*, *energy storage*, demand side options and *network reinforcement* options are given due and reasonable consideration;
 - (3) take account of and be consistent with the allocation of risk where this has been agreed between *transmission network owners* and/or *transmission network service providers* (as appropriate) and *transmission network users*;
 - (4) provide a fair and reasonable risk-adjusted cash flow rate of return to *transmission network owners* and/or *transmission network service providers* (as appropriate) on efficient investment given efficient operating and maintenance practices on the part of the *transmission network owners* and/or *transmission network service providers* (as appropriate) where:
 - (i) *assets* created at any time under a *take or pay contract* are valued in a manner consistent with the provisions of that contract;
 - (ii) *assets* created at any time as part of a *network reinforcement* endorsed or approved by the appropriate Regulatory authority are valued in a manner which is consistent with that endorsement or approval;
 - (iii) subject to clauses 5.2.3(c)(4)(i) and (ii), *assets* (also known as “sunk *assets*”) in existence and generally in service on 30 June 2002 are valued at the value provided that the value of these sunk *assets* must not exceed the deprival value of the *assets* and the *Commission* may require the opening *asset* values to be independently verified;
 - (iv) subject to clauses 5.2.3(c)(4)(i), (ii) and (iii), valuation of *assets* brought into service after 30 June 2004 (“new *assets*”), any subsequent revaluation of any new *assets* and any subsequent revaluation of *assets* existing and generally in service on 30 June 2004 is to be undertaken on a basis to be determined by the *Commission* and in determining the basis of *asset* valuation to be used, the *Commission* must have regard to:
 - (A) generally acceptable valuation methods;
 - (B) any subsequent decisions of the *Commission*; and
 - (C) such other matters reasonably required to ensure consistency with the objectives specified in clause 5.2.2; and
 - (v) benchmark returns to be established by the *Commission* are to be consistent with the method of valuation of new *assets* and revaluation, if any, of existing *assets* and consistent with achievement of a commercial economic return on efficient investment;
 - (5) provide reasonable certainty and consistency over time of the outcomes of regulatory processes having regard for:
 - (i) the need to balance the interests of *transmission network users* and *transmission network owners* and/or *transmission network service providers* (as appropriate);

- (ii) the capital intensive nature of the *transmission* sector, the relatively long lives of *transmission assets*, and the large and relatively infrequent *reinforcement* of the *transmission network*;
- (iii) the need to minimise the economic cost of Regulatory actions and uncertainty;
- (iv) relevant previous regulatory decisions made by authorised persons including:
 - (A) the initial revenue setting and *asset* valuation decisions made by the *Commission* in the context of industry reform, AND
 - (B) decisions made by the *Minister* and Cabinet.

5.2.4 Form and mechanism of economic regulation

- (a) Economic regulation is to be incentive-based and may take into account the performance of the *transmission network owner* and/or *transmission network service provider* (as appropriate) under any service standards imposed by the *Code* or by any applicable Regulatory regime, provided it is consistent with the objectives and principles outlined in clauses 5.2.2 and 5.2.3.
- (b) In setting the revenue requirement for each *transmission network owner* and/or *transmission network service provider* (as appropriate), the *Commission* must take into account:
 - (1) the demand growth which the *transmission network owner* and/or *transmission network service provider* (as appropriate) is expected to service;
 - (2) the service standards applicable to the *transmission network owner* and/or *transmission network service provider* (as appropriate) and any other standards imposed on the *transmission network owner* and/or *transmission network service provider* (as appropriate) by any applicable Regulatory regime or by agreement with the relevant *Network users*;
 - (3) the *Commission*'s reasonable judgment of the potential for efficiency gains to be realised by the *transmission network owner* and/or *transmission network service provider* (as appropriate) in expected operating, maintenance and capital costs, taking into account the expected demand growth and service standards referred to in clauses 5.2.4(b)(1) and (2);
 - (4) the weighted average cost of capital of the *transmission network owner* and/or *transmission network service provider* (as appropriate) applicable to the relevant *network service*, having regard to the risk adjusted cash flow rate of return required by investors in commercial enterprises facing similar business risks to those faced by the *transmission network owner* and/or *transmission network service provider* (as appropriate) in the provision of that *network service*;
 - (5) the provision of a fair and reasonable risk-adjusted cash flow rate of return on prudent investment including sunk *assets* subject to the provisions of clause 5.2.3(c)(4);
 - (6) any taxes and statutory levies paid by the *transmission network owner* and/or *transmission network service provider* (as appropriate) in connection with the provision of *transmission services*;
 - (7) payments to any *electric power producer* providing *network support services*;
 - (8) the on-going commercial viability of the *transmission* industry;

- (9) the amount of any reduction in prices for *prescribed services* recovered from other *transmission consumers* in the preceding Regulatory Control period;
- (10) any other relevant financial indicators; and
- (11) any charter, licence or obligation under the *Act*, the regulations made under the *Act* or this *Code* that applies, or is likely to apply, to the *transmission network owner* and/or *transmission network service provider* (as appropriate).

5.2.5 Information disclosure by Transmission Network Service Provider

- (a) A *transmission network owner* and/or *transmission network service provider* (as appropriate) must submit audited regulatory accounts to the *Commission* (in a form and by a date to be determined by the *Commission*) which provide a true and fair statement of the financial and operating performance of the *transmission network owner* and/or *transmission network service provider* (as appropriate) in a reporting period.
- (b) The audited regulatory accounts provided by the *transmission network owner* and/or *transmission network service provider* (as appropriate) under clause 5.2.5(a) must include:
 - (1) such information as the *Commission* may reasonably require to prepare and publish annual performance statistics in relation to the service standards published by the *transmission network owner* and/or *transmission network service provider* (as appropriate);
 - (2) information on the amount of each instance of a reduction in tariffs payable by a *network user* for the relevant *prescribed services*, provided by the *transmission network owner* and/or *transmission network service provider* (as appropriate) for the relevant *financial year*;
 - (3) information on each instance of a reduction in prices that was recovered from other *transmission consumers* in that *financial year*; and
 - (4) information to substantiate any claim by the *transmission network owner* and/or *transmission network service provider* (as appropriate) that the information provided to the *Commission* with respect to reductions in prices payable by a *network user* for the relevant *prescribed services* under clause 5.2.5(b)(2) and (3) is *confidential information*.
- (c) The audited regulatory accounts submitted by the *transmission network owner* and/or *transmission network service provider* (as appropriate) to the *Commission* may be used by the *Commission* to:
 - (1) monitor the compliance of the *transmission network owner* and/or *transmission network service provider* (as appropriate) with the revenue requirement;
 - (2) assess the allocation of costs between services which are subject to regulation under the revenue requirement and services or activities which are not subject to regulation under the revenue requirement, and to identify any cross-subsidy between these different types of services or activities;
 - (3) collate data regarding the financial, economic and operational performance of the *transmission network owner* and/or *transmission network service provider* (as appropriate), to be used as input to the *Commission's* decision-making regarding the setting of revenue requirements or other regulatory controls to apply in future Regulatory control periods;

- (4) set and publish annual performance statistics in relation to the service standards published by the *transmission network owner* and/or *transmission network service provider* (as appropriate);
 - (5) publish aggregate information on the amount of any reductions in prices payable by a *network user* for the relevant *prescribed services* provided by the *transmission network owner* and/or *transmission network service provider* (as appropriate) in the relevant *financial year* and the percentage of the reductions in the prices that was recovered from other *transmission consumers* in that *financial year*.
- (d) The *Commission* may request or undertake verification and/or independent audit of any information sought by it, or provided to it.

PART C - TRANSMISSION PRICING

Outlines of the various *transmission network service* costs are detailed in Schedule 5.2.

5.3 TRANSMISSION NETWORK SERVICE PROVIDER PRUDENT REQUIREMENTS

This clause sets out the arrangements by which *transmission network service providers* may minimise financial risks associated with investment in *network assets*.

5.3.1 Prudent requirements for network service

- (a) A *transmission network service provider* may require an *electric power producer*, *transmission consumer* or another person having a *connection point* on the *transmission network* to establish prudential requirements for *connection service* and/or *transmission network use of system service*. These prudent requirements may take the form of, but need not be limited to, capital contributions, pre-payments or financial guarantees.
- (b) Prudent requirements for *connection service* and/or *transmission network use of system service* are a matter for negotiation between the *transmission network service provider* and the *electric power producer*, *transmission consumer* or another person having a *connection point* on the *transmission network* and the terms agreed must be set out in the *connection agreement* between the relevant *transmission network service provider*, the *electric power producer*, the *transmission consumer* and any other person having a *connection point* on the *transmission network*.

5.3.2 Capital contribution or prepayment for a specific asset

Where the *transmission network service provider* is required to construct specific *assets* to provide *connection service* or *transmission network use of system service* to an *electric power producer*, *transmission consumer* or another person having a *connection point* on the *transmission network*, the *transmission network service provider* may require that person to make a capital contribution or prepayment for all or part of the cost of the new *assets* installed and any contribution made must be taken into account in the determination of *transmission service* prices applicable to that person.

5.3.3 Treatment of past capital contributions

- (a) The treatment of capital contributions made by *electric power producers*, *transmission consumers* or another person having a *connection point* on the *transmission network* for *connection service* or *transmission network use of system service* prior to the introduction of the *Code* must be in accordance with existing contractual arrangements with the relevant *transmission network service providers*.

- (b) Where contractual arrangements referred to in clause 5.3.3(a) are not in place, the treatment of past capital contributions for *connection service* or *transmission network use of system service* must be negotiated by the *electric power producer*, *transmission consumer* or another person having a *connection point* on the *transmission network* and the *transmission network service provider*.

5.4 BILLING AND SETTLEMENTS PROCESS

This clause describes the manner in which *electric power producers* and *transmission consumers* are billed for *transmission service* and how payments for *transmission service* are settled.

5.4.1 Billing for transmission service

- (a) For each *connection point* on his *transmission network*, a *transmission network service provider* must calculate the *transmission service* charges payable by *electric power producers*, *transmission consumers* or other persons with *connection points* on the *transmission network*.
- (b) Where the billing for a particular *financial year* is based on quantities which are undefined until the year is at least partially over, charges are to be estimated from the previous year's billing quantities with a reconciliation to be made when the actual billing quantities are known and where previous year's billing quantities are unavailable or no longer suitable, nominated quantities may be used as agreed between the parties.
- (c) Where *transmission service* charges are to be determined from *metering data*, these charges will be based on kW or kWh obtained from the *metering data* managed by the relevant *Code Participant*.

5.4.2 Minimum information to be provided in network service bills

The minimum information to be provided with a bill by a *transmission network service provider* directly to an *electric power producer* or *transmission consumer* for a *connection point* is:

- (a) the *connection point* identifier;
- (b) the dates on which the billing period starts and ends;
- (c) the date on which payment is due;
- (d) the identifier of the published *transmission service* price from which the *connection point* charges are calculated; and
- (e) measured quantities, billed quantities, agreed quantities, prices and amounts charged for each component of the *electric power producer's* or *transmission consumer's* total *transmission service* account.

5.4.3 Obligation to pay

A *network user* must pay *transmission service* charges properly charged to him and billed in accordance with clause 5.4, by the due date specified in the bill.

PART D - NETWORK PRICING FOR DISTRIBUTION SYSTEMS

This part of the *Code* applies to the Regulatory requirements in respect of the general level of price controls for *distribution services*.

5.5 GENERAL REGULATION OF DISTRIBUTION NETWORK PRICING

5.5.1 Guidelines for distribution service pricing

- (a) The arrangements specified in Part D:

- (1) set out the objectives and principles which may be applied in economic regulation of *distribution service* pricing;
- (2) provide for the adoption of national guidelines (to the extent considered appropriate by the *Commission*) by which the objectives and principles referred to in clause 5.5.2 and 5.5.3 may be applied; and
- (3) recognise the ongoing role of the *distribution service* pricing regime which will continue to exist in Kenya to which it may be inappropriate to apply national guidelines for *distribution service* pricing.

5.5.2 Objectives of distribution service pricing

The *distribution service* pricing Regulatory regime to be administered under Part D of the *Code* must seek to achieve the following outcomes:

- (a) an efficient and cost-effective Regulatory environment;
- (b) an incentive-based Regulatory regime which:
 - (1) provides an equitable allocation between *distribution network users* and *distribution network service providers* of efficiency gains reasonably expected by the *Commission* to be achievable by the *distribution network service providers*;
 - (2) provides for, on a prospective basis, a sustainable commercial revenue stream which includes a fair and reasonable rate of return to *distribution network service providers* on prudent investment, given efficient operating and maintenance practices of the *distribution network service providers*;
 - (3) ensures consistency in the application of regulations applicable to:
 - (i) *connection to distribution networks*; and
 - (ii) *distribution service* pricing;
- (c) prevention of monopoly rent extraction by *network owners*;
- (d) an environment which fosters a prudent level of investment within the *distribution* sector, and upstream and downstream of the *distribution* sector;
- (e) an environment which fosters efficient operating and maintenance practices within the *distribution* sector;
- (f) an environment which fosters efficient use of existing infrastructure;
- (g) reasonable recognition of pre-existing policies of the Kenyan *government* regarding *distribution asset* values;
- (h) promotion of competition in upstream and downstream markets and promotion of competition in the provision of *network services* where economically feasible;
- (i) reasonable Regulatory accountability through transparency and public disclosure of Regulatory processes and the basis of Regulatory decisions;
- (j) reasonable certainty and consistency over time of the outcomes of Regulatory processes, recognising the adaptive capacities of *Code Participants* in the provision and *use of distribution network assets*;
- (k) reasonable and well defined Regulatory discretion which permits an acceptable balancing of the interests of *distribution network service providers*, *distribution network users* and the public interest.

5.5.3 Principles for regulation of distribution service pricing

The regime under which the revenues and/or prices of *distribution network service providers* are to be regulated is to be administered by the *Commission* in accordance with the following principles and Schedule 5.4:

- (a) Concerns over monopoly pricing in respect of the *distribution network* will, wherever economically efficient and practicable, be addressed through the introduction of competition in the provision of *distribution services*.
- (b) Where pro-competitive and structural reforms alone are not a practicable or adequate means of addressing the problems of monopoly pricing in respect of *distribution services* or protecting the interests of *distribution network users*, the form of economic regulation to be applied is described in clause 5.5.5.
- (c) The form of economic regulation applied by the *Commission* must not be changed during a Regulatory control period.
- (d) Subject to clause 5.5.3(c), if the *Commission* proposes to amend the form of economic regulation specified in clause 5.5.5 applied to a *distribution network service provider*, the *Commission* must:
 - (1) give two years prior notice to the *distribution network service providers* of the new economic regulation arrangements to apply from the commencement of the next Regulatory control period; and
 - (2) publish a description of the process and timetable for re-setting the form of economic regulation at a time which provides all affected parties with adequate notice to prepare for, participate in, and respond to that process, prior to the commencement of the Regulatory control period to which that form of economic regulation is to apply.
- (e) The Regulatory regime to be administered by the *Commission* must be consistent with the objectives outlined in clause 5.5.2 and must also have regard to the need to:
 - (1) provide *distribution network service providers* with incentives and reasonable opportunities to increase efficiency;
 - (2) create an environment in which *generation*, *energy storage*, demand side options and *network reinforcement* options are given due and reasonable consideration;
 - (3) take account of and be consistent with the allocation of risk between *network service providers* and *network users*;
 - (4) take account of and be consistent with any obligations of *Code Participants* in relation to *distribution networks* under Chapter 3;
 - (5) provide a fair and reasonable risk-adjusted cash flow rate of return to *distribution network service providers* on efficient investment given efficient operating and maintenance practices on the part of the *distribution network service providers* where:
 - (i) *assets* created at any time under a *take or pay contract* are valued in a manner consistent with the provisions of that contract;
 - (ii) subject to clause 5.5.3(e)(5)(i), *assets* (also known as “sunk *assets*”) in existence and generally in service on 1 July 2002 are valued at a value determined by the *Commission* or consistent with the Regulatory *asset* base established in Kenya;
 - (iii) subject to clause 5.5.3(e)(5)(i), valuation of *assets* brought into service after 1 July 2002 (“new *assets*”), any subsequent revaluation of any new *assets* and any subsequent revaluation of *assets* existing and generally in service on

1 July 2002 is to be undertaken on a basis to be determined by the *Commission*. In determining the basis of *asset* valuation to be used, the *Commission* must have regard to:

- (A) the depreciated replacement value should be the preferred approach to valuing *network assets*;
 - (B) any subsequent relevant decisions of the *government*; and
 - (C) such other matters reasonably required to ensure consistency with the objectives specified in clause 5.5.2, including methodologies developed or applied by the *Commission*; and
- (iv) benchmark returns to be established by the *Commission* are to be consistent with the method of valuation of new *assets* and revaluation, if any, of existing *assets* and consistent with achievement of a commercial economic return on efficient investment;
- (6) provide reasonable certainty and consistency over time of the outcomes of Regulatory processes having regard for:
- (i) the need to balance the interests of *network users* and *network owners*;
 - (ii) the capital intensive nature of the *distribution* sector, the relatively long lives of *distribution assets*, and the variable and frequent *reinforcement* of the *distribution network*;
 - (iii) the need to minimise the economic cost of Regulatory actions and uncertainty;
 - (iv) relevant previous Regulatory decisions made by authorised persons including:
 - (A) the initial revenue setting and *asset* valuation decisions, and
 - (B) decisions made by the *Commission* and any Regulatory intentions previously expressed.

5.5.4 Economic regulation of distribution services

- (a) The *Commission* is responsible for determining which, if any, *distribution services* provided by a *distribution network service provider* (as appropriate) should be deemed to be *prescribed distribution services* and accordingly subject to economic regulation in accordance with the principles set out in clauses 5.5.3 and 5.5.5. In making this determination the *Commission* is to have regard to:
- (1) the principles for regulation of *distribution service* pricing described in clause 5.5.3;
 - (2) the extent of effective competition in the provision of that *distribution service*;
 - (3) whether sufficient competition exists to warrant the application of a Regulatory approach which is more “light-handed” than the approach described in clause 5.5.5;
 - (4) the effectiveness of the form of economic regulation specified under 5.5.5 in achieving the efficiency objectives included in clause 5.5.2; and
 - (5) the form, if any, of that regulation.
- (b) *Distribution services* which are not *prescribed distribution services* are deemed to be excluded *distribution services* and without limiting the discretion of the *Commission* under clause 5.5.4(a), excluded *distribution services* are those to which

it is appropriate to apply a Regulatory approach which is more “light-handed” than the regulation described in clause 5.5.5 and the *Commission* must determine the form of regulation which is to be applied to excluded *distribution services*.

5.5.5 Form and mechanism of economic regulation

In respect of *distribution services* subject to economic regulation pursuant to clause 5.5.4(a):

- (a) Economic regulation shall be incentive-based and consistent with the objectives and principles outlined in clauses 5.5.2 and 5.5.3.
- (b) The *Commission* shall specify the form of economic regulation to be applied to the *distribution network service provider*.
- (c) The *Commission* is to apply the form of economic regulation specified in clauses 5.5.5(a) and (b) to each *distribution network service provider* for the Regulatory control period which is to be a period of not less than 3 years and not more than 5 years.
- (d) In setting separate price controls to be applied to each *distribution network service provider* in accordance with clause 5.5.5(b), the *Commission* must take into account each *distribution network service provider*’s revenue requirements during the Regulatory control period, having regard for:
 - (1) the demand growth which the *distribution network service provider* is expected to service using any appropriate measure including but not limited to:
 - (i) *energy* consumption by categorisation of *distribution consumers* or other relevant groups of persons who consume *energy*;
 - (ii) demand by categorisation of *distribution consumers* or other relevant groups of persons who consume *energy*;
 - (iii) numbers of *distribution consumers* or other relevant groups of persons who consume *energy* by categorisation of *distribution consumers*;
 - (iv) length of the *distribution network*; and
 - (v) the nature of the *distribution network*;
 - (2) the service standards applicable to the *distribution network service provider* under the *Code* and any other standards imposed on the *distribution network service provider* by any Regulatory regime administered by the *Commission* or by agreement with the relevant *network users*;
 - (3) price stability;
 - (4) the *Commission*’s reasonable judgment of the potential for efficiency gains to be realised by the *network owner* in expected operating, maintenance and capital costs, taking into account the expected demand growth and service standards referred to in clauses 5.5.5(d)(1) and (2);
 - (5) the *distribution network service provider*’s weighted average cost of capital applicable to the relevant *network service*, having regard to the risk adjusted cash flow rate of return required by investors in commercial enterprises facing similar business risks to those faced by the *distribution network service provider* in the provision of that *network service*;
 - (6) the provision of a fair and reasonable risk-adjusted cash flow rate of return on prudent investment including sunk *assets* subject to the provisions of clause 5.5.3(e)(5);

- (7) the Right of the *distribution network service provider* to recover reasonable costs arising from but not limited to:
- (i) any statutory taxes which he has paid in connection with the operation of his business as a provider of *distribution services*;
 - (ii) charges paid to *transmission network service providers* and other *distribution network service providers* arising from the provision of *distribution services*;
 - (iii) payments made to *electric power producers* for *embedded generators* for demand side management programs and local *energy storage facilities* which provide *distribution service* of a kind set out in or similar to those set out in part 4.5 of schedule 5.3 or in accordance with clause 3.6.3 where the *Commission* determines that this is appropriate;
- (8) any correction factors arising from the previous Regulatory period;
- (9) any reduction or increase in *energy losses* in the *distribution network*;
- (10) the on-going commercial viability of the *distribution* industry;
- (11) any capital contributions, prepayments and financial guarantees arranged by the *distribution network service provider* under clause 5.6; and
- (12) any other relevant financial indicators.
- (e) Notwithstanding clause 5.5.5(c), the *Commission* may revoke a determination during a Regulatory control period only where it appears to the *Commission* that:
- (1) the determination was set on the basis of false or materially misleading information provided to the *Commission*;
 - (2) there was a material error in the setting of the determination and the prior written consent of parties affected by any proposed subsequent re-opening of the determination has been obtained by the *Commission*; or
 - (3) any person is materially adversely affected by the determination as a result of an event beyond the person's control which was not contemplated when the determination was made and where there are net public benefits in revoking the determination.
- (f) If the *Commission* revokes a determination under clause 5.5.5(e), then the *Commission* must make a new determination in substitution for the revoked determination to apply for the remainder of the Regulatory control period for which the revoked determination was to apply.
- (g) Prior to the end of a Regulatory control period, the *Commission* must publish a description of the process and timetable for re-setting the level of price controls to apply in the next Regulatory control period and must provide to all affected parties adequate notice to allow them to prepare for, participate in, and respond to that process.
- (h) A *distribution network service provider* must use reasonable endeavours to ensure that he complies with the price controls in respect of *distribution services* in any year.

5.5.6 Monitoring of Distribution Network Owner performance and compliance with Regulatory determinations

- (a) A *distribution network service provider* must submit audited regulatory accounts to the *Commission* (in any reasonable form which may be determined by the *Commission*) which provide a true and fair statement of:
 - (1) the economic performance of the *distribution network service provider* in a reporting period; and
 - (2) the value of the *distribution network assets* and *connection assets* for the purpose of determining the *distribution service* prices.
- (b) The audited regulatory accounts submitted by a *distribution network service provider* to the *Commission* may be used by the *Commission* to:
 - (1) monitor the compliance of the *distribution network service provider* with the price Controls; and
 - (2) collate data regarding the financial, economic and operational performance of the *distribution network service provider* to be used as input by the *Commission* in respect of the determination of Regulatory caps to apply in future Regulatory control periods.
- (c) The *Commission* may request or undertake verification and/or independent audit of any information sought by it, or provided to it under this clause 5.5.6.
- (d) Information provided to the *Commission* by a *distribution network service provider* pursuant to clauses 5.5.6(a) and (b) must be treated as confidential by the *Commission* and must not be disclosed to any other party without the prior written consent of the *distribution network service provider* which provided the information unless the procedures set out in clause 5.5.7(d)-(f) have been followed.

5.5.7 Information disclosure by the Commission

- (a) This clause 5.5.7 is subject to clause 5.5.6
- (b) In making a determination or any other decision under this clause 5.5, the *Commission* must publish reasonable details of the basis and rationale of its decision and the information to be disclosed publicly by the *Commission* is to include, but not be limited to the following:
 - (1) reasonable details of qualitative and quantitative methodologies applied including any calculations and formulae; and
 - (2) full reasons for all material judgments and qualitative decisions made and options considered and all discretions exercised which have a material bearing on the outcome of the *Commission*'s decision.
- (c) Notwithstanding clause 5.5.7(b), the *Commission* must also disclose relevant information to the relevant *distribution network service provider* only on request by the *distribution network service provider* and such information is to include, but not be limited to the following:
 - (1) the values adopted by the *Commission* for each of the input variables in any calculation and formulae, including a full description of the rationale for adoption of those values; and
 - (2) full and reasonable details of other assumptions made by the *Commission* in the conduct of all material qualitative and quantitative analyses undertaken in relation to the setting of a Regulatory cap or related matter.
- (d) The *Commission* in discharging its functions under the *Code* may publicly release information or the contents of documents provided to it by a *distribution network*

service provider who has declined to give written consent to its release in accordance with clause 5.5.6 if the *Commission*:

- (1) is of the opinion that:
 - (i) the disclosure of the information or the contents of the documents would not cause detriment to the *distribution network service provider* who supplied it; or
 - (ii) although the disclosure of the information or the contents of the documents would cause detriment to the *distribution network service provider* who supplied it, the public benefit in disclosing it outweighs that detriment; and
 - (2) is of the opinion, in relation to any other person who has provided the *distribution network service provider* with information or documents that form part of the information or documents provided by the *distribution service provider* to the *Commission*, that:
 - (i) the disclosure of the information or contents of the documents would not cause detriment to that person; or
 - (ii) although the disclosure of the information or contents of the documents would cause detriment to that person, the public benefit in disclosing it outweighs the detriment, and the procedures set out in clause 5.5.7(e) to (f) have been followed.
- (e) The *Commission* must not publicly release any information or the contents of any documents under clause 5.5.7(d) until the expiration of 28 *days* from the date of receipt of a written notice sent by the *Commission* to:
- (1) the *distribution network service provider* who supplied the information or documents; or
 - (2) any person whom the *Commission* is aware supplied the *distribution network service provider* with information or documents that form part of the information or documents provided to the *Commission* by the *distribution network service provider*, of the *Commission*'s intention to disclose.
- (f) The notice referred to in clause 5.5.7(e) must:
- (1) state that the *Commission* wishes to disclose the information or contents of the documents, specifying the nature of the intended disclosure and setting out detailed reasons why the *Commission* wishes to make the disclosure;
 - (2) state that the *Commission* is of the opinion required by clause 5.5.7(d) and setting out detailed reasons why it is of that opinion; and
 - (3) identify the legislation (if any) governing the review of decisions by the *Commission* to release information.
- (g) Where as a result of a review under the legislation (if any) referred to in clause 5.5.7(f)(3) of its decision to publicly release information or documents the *Commission* is not allowed to disclose particular information or documents provided to it for the purpose of performing its functions under the *Code*, the *Commission* may nonetheless use the information or document for the purposes of performing its functions under the *Code*.
- (h) Nothing in clause 5.5.7(e) and (f) is intended to affect a *Code Participant*'s rights to seek a review under general principles of administrative law of the *Commission*'s decision to release any information or the contents of any documents under clause 5.5.7(d).

PART E - DISTRIBUTION NETWORK PRICING

Outlines of the various *distribution network service* costs are detailed in Schedule 5.3.

5.6 DISTRIBUTION NETWORK SERVICE PROVIDER PRUDENT REQUIREMENTS

This clause sets out the arrangements by which *distribution network service providers* may minimise financial risks associated with investment in *network assets*, and to achieve cost-reflective payment options in conjunction with the use of average *distribution* prices. The clause also prevents *distribution network service providers* from receiving income twice for the same *assets* through prudent requirements and *distribution service* prices.

5.6.1 Prudent requirements for distribution network service

- (a) A *distribution network service provider* may require an *electric power producer* with an *embedded generator* or *distribution consumer* that requires a new *connection* or a modification in service for an existing *connection* to establish prudent requirements for *connection service* and *distribution use of system service*.
- (b) Prudent requirements for *connection service* and *distribution network use of system service* are a matter for negotiation between the *distribution network service provider* and the *electric power producer* with an *embedded generator* or *distribution consumer* and the provisions agreed must be set out in the *connection agreement* between the *distribution network service provider* and the *electric power producer* with an *embedded generator* or *distribution consumer*.
- (c) The *connection agreement* may include one or more of the following provisions:
 - (1) the conditions under which and the time frame within which other *network users* who use that part of the *distribution network* contribute to refunding all or part of the payments;
 - (2) the conditions under which financial arrangements may be terminated; and
 - (3) the conditions applying in the event of default by the *distribution consumer* or *electric power producer* with an *embedded generator*.
- (d) Prudent requirements may incorporate, but are not limited to one or more of the following arrangements:
 - (1) financial capital contributions;
 - (2) non-cash *asset* contributions;
 - (3) *distribution service* charge prepayments;
 - (4) guaranteed minimum *distribution service* charges for an agreed period;
 - (5) guaranteed minimum *distribution service* quantities for an agreed period; and
 - (6) provision of financial guarantees for *distribution service* charges.

5.6.2 Capital contributions, pre-payments and financial guarantees

The principles to be applied to capital contributions, pre-payments and financial guarantees are;

- (a) the *distribution network service provider* is not entitled to receive any *asset* related cost component of price controls for *assets* provided by *network users*;

- (b) the *distribution network service provider* may receive a capital contribution, prepayment and/or financial guarantee up to the future price controls for any new *assets* installed as part of a new *connection* or modification to an existing *connection*, including any *reinforcement* to the *distribution network*.
- (c) where *assets* have been the subject of a contribution or prepayment, the *distribution network service provider* must amend the aggregate price controls; and
- (d) any capital contributions, prepayments and financial guarantees arranged by the *distribution network service provider* under this clause 5.6 are subject to consideration by the *Commission* under clause 5.5.5(d).

5.6.3 Treatment of past pre-payments and capital contributions

- (a) Payments made by *consumers* and *electric power producers* with *embedded generators* for *distribution service* prior to the introduction of the *Code* must be made in accordance with any existing contractual arrangements with *distribution network service providers*.
- (b) Where specific contractual arrangements are not in place, past *distribution service* pre-payments or capital contributions may be incorporated in the capital structure of the *distribution network service provider*'s business.
- (c) The *Commission* may intervene in and resolve any dispute under this clause 5.6.3 which cannot be resolved between the relevant *consumer*, *electric power producer* with an *embedded generator* and the *distribution network service provider*.

5.7 BILLING AND SETTLEMENTS PROCESS

This clause describes the manner in which *distribution consumers* and *electric power producer* with *embedded generators* are billed by *distribution network service providers* for *distribution service* and how payments for *distribution service* are settled.

5.7.1 Billing for distribution network services

- (a) A *distribution network service provider* must calculate the *distribution service* charges payable by *network users* for *distribution services*.
- (b) Subject to clause 5.7.1(e), where a *distribution consumer* (other than a *public electricity supplier*) incurs *distribution network* charges, the *distribution network service provider* must bill the *public electricity supplier* from whom the *distribution consumer* purchases electricity directly or indirectly for such *distribution services*.
- (c) If a *contestable consumer* and the *public electricity supplier* from whom he purchases electricity agree, the *distribution network service provider* may bill the *contestable consumer* directly for *distribution services* used by that *contestable consumer*.
- (d) Where the billing for a *distribution consumer* for a particular *financial year* is based on quantities which are undefined until after the commencement of the *financial year*, charges are to be estimated from the previous year's billing quantities with a reconciliation to be made when the actual billing quantities are known.
- (e) Where the previous year's billing quantities are unavailable or no longer suitable nominated quantities may be used as agreed between the parties.

5.7.2 Minimum information to be provided in distribution network service bills

The minimum information to be provided directly to a *Code Participant* for a *distribution network connection point* is:

- (a) the *distribution network connection point* identifier;
- (b) the dates on which the billing period starts and ends;
- (c) the date on which payment is due;
- (d) the identifier of the *distribution service* price from which the *connection point* charges are calculated; and
- (e) measured quantities, billed quantities, prices and amounts charged for each component of the *distribution consumer's* total *distribution service* account.

5.7.3 Settlement between distribution network service providers

The billing and settlement process specified in this clause 5.7 must be applied to all *distribution consumers* including other *distribution network service providers* (if any).

5.7.4 Obligation to pay

A *network user* must pay *distribution service* charges properly charged to him and billed in accordance with this clause 5.7 by the due date specified in the bill.

5.8 DISTRIBUTION NETWORK SERVICE PRICING RECORDS

Each *distribution network service provider* must maintain appropriate *distribution service* pricing records that satisfy any requirement of the *Commission*.

5.9 DATA REQUIRED FOR DISTRIBUTION NETWORK SERVICE PRICING

5.9.1 Forecast use of networks by Distribution Consumers and electric power producer with embedded generators

The information required by *distribution network service providers* is to be provided by *Code Participants* as part of the *connection* and access requirements set out in Chapter 3 of the *Code*.

5.9.2 Confidentiality of distribution network pricing information

All information used by *distribution network service providers* for the purposes of *distribution service* pricing is *confidential information*.

SCHEDULES TO CHAPTER 5

TABLE OF CONTENTS

| | Page |
|---|------|
| SCHEDULE 5.1 | |
| ESTIMATING WEIGHTED AVERAGE COST OF CAPITAL | 159 |
| SCHEDULE 5.2 | |
| CATEGORIES OF TRANSMISSION SYSTEM COST | 162 |
| SCHEDULE 5.3 | |
| CATEGORIES OF DISTRIBUTION NETWORK COST | 166 |
| SCHEDULE 5.4 | |
| PRINCIPLES FOR NETWORK PRICING | 177 |
| SCHEDULE 5.5 | |
| TRANSMISSION SYSTEM PLANNING AND SECURITY STANDARD | 178 |

SCHEDULE 5.1**ESTIMATING WEIGHTED AVERAGE COST OF CAPITAL****S5.1.1 BASIS FOR ESTIMATING THE WEIGHTED AVERAGE COST OF CAPITAL OF A NETWORK OWNER**

Studies show that investments by governments in business enterprises are not the same as social expenditures funded from the budget (requiring higher levels of taxation to pay for that), with no prospect of future pay back. The business enterprises produce and sell goods and services which could alternatively be produced and sold by the private sector. Attempts to expand *government* business enterprises through the use of target rates of return lower than the opportunity cost of capital in the private sector would result in a misallocation of resources between the public and private sectors.

Improved resource allocation is more likely to be achieved by having *government* business enterprises operate under financial conditions similar to those in the private sector, rather than by giving public enterprises an investment break. Setting target rates of return for *government* business enterprises on the basis of the marginal rate of return of private sector investments of similar risk is a central part of this even-handed treatment.

Basing target rates of return for public enterprises on the return from alternative private sector investments should result in sound investment and operational decisions at the *government* enterprise level and balanced investment between the public and private sectors.

The following Schedule outlines an approach to estimating the cost of capital of a government-owned *network owner* in the Kenyan Electricity Industry. The approach outlined herein is consistent with that outlined in the NERA Report on *Review of Electricity Tariff Policy in Kenya* of 2002.

The objective of competitive neutrality policy is the elimination of resource allocation distortions arising out of the public ownership of entities engaged in significant business activities. *Government* businesses should not enjoy any net competitive advantage simply as a result of their public sector ownership.

S5.1.2 OUTLINE OF METHOD FOR ESTIMATING A NETWORK OWNER'S WEIGHTED AVERAGE COST OF CAPITAL**S5.1.2.1 Definition of weighted average cost of capital**

The weighted average cost of capital is a “forward looking” weighted average cost of debt and equity for a commercial business entity. Accordingly, the *network owner's* weighted average cost of capital will represent the shadow price or social opportunity cost of capital as measured by the rate of return required by investors in a privately-owned company with a risk profile similar to that of the *network* company.

The terms “required economic rate of return”, “target rate of return” and “cost of capital” are synonymous and are used interchangeably throughout this schedule.

S5.1.2.2 Cost of equity

There is a variety of methods which can be applied to estimate the cost of equity capital of a business enterprise. The Capital Asset Pricing Model (CAPM) remains the most widely accepted tool applied in practice to estimate the cost of equity.

The CAPM is a model based on the proposition that the required rate of return on equity is equal to the risk-free rate of return plus a risk premium.

The theory underlying the CAPM is rigorous. However, in applying the CAPM, there should be a recognition of the limitations of the model. The limitations of CAPM, as with any model, relate mainly to the measurement and estimation of relevant input variables. Consequently, the CAPM should be regarded as providing an indication of the cost of equity, rather than a firm and precise measurement.

S5.1.2.3 Cost of debt

The cost of debt is estimated with reference to current prices in domestic and overseas corporate debt markets. Given the long lives of *network assets*, the cost of debt should reflect the cost of a long-dated debt portfolio.

S5.1.3 ESTIMATION OF THE COST OF EQUITY

The *network owner's* required rate of return on equity is estimated using the Capital Asset Pricing Model (CAPM):

$$R_e = R_f + \beta (R_m - R_f)$$

Where:

R_e = required rate of return on equity, after company tax

R_f = risk - free rate

$(R_m - R_f)$ = the risk premium above the risk-free rate required for a market-weighted (i.e. diversified) portfolio of securities

β = a measure of the *asset's* riskiness relative to the market

The approach to estimating values for each of the inputs to the CAPM is outlined in detail below.

S5.1.3.1 Risk-free rate

The risk free rate is normally taken to be the yield to maturity on long term (6 year) Treasury bonds, with the equity market risk premium (see section 3.2 below) also measured historically from such a benchmark.

S5.1.3.2 Equity market risk premium

The equity market risk premium (MRP) can be observed by considering the historical data of yield gaps between returns on equity, R_m and returns on risk-free debt, R_f , namely:

$$MRP = R_m - R_f$$

S5.1.3.3 Beta

Beta is a measure of the extent to which the return on a given equity investment moves with the return on the equity market.

Where beta data is not available, it is necessary to estimate a beta factor. This can be done by observing the beta factors of listed companies which have similar business risk profiles and capital structures.

S5.1.3.4 Capital structure and market risk premium

The risk premium sought by equity investors will be a function of:

- (a) the underlying market risk (volatility) of the pre-financing cash flows of the investment, and
- (b) the level of financial risk, which is in turn dependent on the capital structure of the entity.

Published data on share market betas and related market risk premia relate to equity returns, and therefore reflect the market risk and the financial risk faced by investors.

To ensure validity of the CAPM calculations, it is necessary to apply assumptions of capital structure and market risk premia which are consistent with one another. In addition, where beta and other data relating to listed companies are being used to impute a cost of equity for a state owned enterprises (SOE), the capital structures of the SOE and the private sector surrogate(s) should be reasonably comparable. This ensures that the beta imputed for the SOE correctly reflects the financial and market risk of the SOE.

S5.1.4 DETERMINATION OF THE COST OF DEBT

S5.1.4.1 The question of the Government Guarantee on borrowings

The Treasury requires that where the SOE has access to *government* guaranteed borrowings, the guarantor should charge the SOE a fee for provision of the *government* guarantee. The guarantee fee would generally be the difference between the cost of *government* debt and the cost of debt which would be faced by the enterprise if it was privately owned.

Application of the fee in this manner would increase the SOE's cost of debt to levels which reflect its full opportunity cost. This approach is consistent with the principles outlined in section 1 of this schedule.

S5.1.4.2. Estimating the cost of debt

Typically, a *network owner* will have a portfolio of debt consisting of lines of debt with different maturities, durations and yields. Given the long life of *transmission assets* this debt portfolio would typically be long-dated. A weighted average cost of debt should be estimated, taking into account the maturity and duration characteristics of the portfolio and the associated current market yields. Market yields applicable to the debt should reflect fully the *network owner's* credit risk.

S5.1.5 DETERMINATION OF THE WEIGHTED AVERAGE COST OF CAPITAL

S5.1.5.1 The relationship between capital structure and weighted average cost of capital

Gearing should not affect a *government* trading enterprise's target rate of return, which implies that shareholder value will also be insensitive to varying levels of debt. For practical ranges of capital structure the required rate of return on total *assets* for a *government* trading enterprise should not be affected by changing debt to equity ratios.

As noted in section 3.4, where beta and other data relating to listed companies are being used to impute a cost of equity for a *government* business enterprise, the capital structures of the SOE and the private sector surrogate(s) should be reasonably comparable. This ensures that the beta imputed for the SOE correctly reflects the financial and market risk of the SOE.

S5.1.5.2 Taxation and the impacts of dividend imputation

Weighted average cost of capital can be defined and expressed in pre-tax terms or after-tax terms. Both definitions of weighted average cost of capital will yield exactly the same results, provided that:

- (a) the definition of cash flows (i.e. costs and revenue requirements) is consistent with the definition of weighted average cost of capital applied; and
- (b) the tax rate used to "gross-up" after tax required return to pre-tax required return is the effective tax rate paid by the company.

SCHEDULE 5.2**CATEGORIES OF TRANSMISSION SYSTEM COST**

This schedule 5.2 describes how the *transmission system* costs are to be formed from the revenue requirements as determined by *network owners*. It describes the *asset* categories which are used, and defines the manner in which the *assets* are to be categorised. It also indicates how the total *transmission system* costs will be allocated between the service categories set out in clause 5.3.1.

The *aggregate annual revenue requirement* of the *transmission network owner* must be separated into four components:

- (a) costs which relate to the provision of *assets* to provide service to the overall *transmission system* and any non-asset related costs which it is also not appropriate to allocate to *users* on a locational basis (called *common service*);
- (b) the cost of providing *assets* which are fully dedicated to providing *connection* to a single *electric power producer* or group *connected* at a single point within the *network* (called *entry assets*);
- (c) the cost of providing *assets* which are fully dedicated to the *supply* of a single *transmission consumer* or group *connected* at a single point within the *network* (called *exit assets*); and
- (d) *assets* which are shared to a greater or lesser extent by all *users* across the *transmission system* (*transmission network assets*).

S5.2.1 COMMON SERVICE COSTS

The *common service* cost category includes all the *transmission service* costs which cannot be allocated to *users* on a locational basis, i.e. they cover those costs which provide equivalent benefits to all *users* within the *transmission system* without any differentiation of their location. These costs are applied to *users* on a postage stamp basis.

There are two types of costs to be included in the *common service* category:

- (a) the cost of *network assets* which provide a *common service*; and
- (b) the cost to the *network owner* of providing non-asset related services to *users*.

S5.2.1.1 Network assets which provide common service

Common service is provided by the following *transmission network assets* and *connection assets*:

- (a) *power system* communications networks;
- (b) control systems;
- (c) *control centres* (excluding *generation* and system control functions);
- (d) dynamic reactive control *plant*;
- (e) *static reactive plant*;
- (f) spare *plant* and equipment including that installed at stations;
- (g) fixed *assets* such as buildings and land that are not associated with station or line easements, e.g. head office buildings, land for future stations etc.; and
- (h) motor vehicles and construction equipment.

S5.2.1.2 Non-asset related common service costs

The non-asset related *common service* costs include the following:

- (a) *network* switching and operations;
- (b) administration and management of the business;
- (c) *network* planning and development; and
- (d) general overheads.

The first step is to identify the non-asset related costs which are to be included in the *common service* category. These will generally need to be identified from budget projections. The difference between the *aggregate annual revenue requirement* and that recovered from the non-asset related *common service* cost category are the *asset* related *network* costs. These costs must be allocated to individual *assets* to allow the cost allocation to be carried out. This is determined through the use of a simple ratio of the *aggregate annual revenue requirement* required from *assets* to the Optimised Replacement Cost of the *network* as determined from the Valuation which is called the Annual Cost Fraction ψ , i.e.:

$$\text{Annual cost fraction } (\psi) = \frac{\text{Aggregate annual revenue requirement of all assets}}{\text{Optimised replacement cost of all assets}}$$

The individual *assets* to which costs are allocated are consistent with those identified in the *network* valuation. Generally only major primary *plant* is separately identified with the costs incorporating all secondary and auxiliary *plant*. The annual cost to be recovered from each individual *asset* can then be determined by application of the above factor to the Optimised Replacement Cost of the *asset* as defined in the *network* valuation.

The *network owner* must separately identify the costs relating to *assets* which provide *common service* and the charges for these are to be recovered through *common service* charges. This is determined by applying the annual cost fraction ψ to the Optimised Replacement Cost of *assets* identified as being in the *common service* category. These costs are then added to the non-asset related *common service* costs identified as above to form the total *common service* cost pool for the *network*.

The category for some *assets* is not clear cut. *Reactive plant* and station establishment costs may fall in the *common service* category depending on their location and use.

These aspects are considered in the following sections.

S5.2.1.3 Reactive plant

Dynamic *reactive plant* is provided for system reasons and is to be treated as a *transmission network asset* and would become part of the *common service* charge to loads.

All existing dynamic and *static reactive plant* in *generating station* switchyards or at the *transmission* level in *load supplying substations* and any associated switchgear and dedicated *transformers* will be charged as shared *network assets* through the *common service* price.

Reactive plant installed at the subtransmission *voltage* level of *transmission* stations should be charged as *transmission network assets* through application of a *common service* price unless it is clearly evident that such *plant* has been provided to meet the local reactive requirements of one or more *network user connected* at that station in which case it may be charged as a *connection asset*.

S5.2.2 ENTRY AND EXIT ASSETS

The entry and exit *asset* costs are recovered from the *network users* who benefit from them and requires no complex analysis to determine the sharing.

A “shallow *connection asset*” policy is to be adopted in which only those *assets* (including individual *assets* within a station) which provide *supply* to only those *network users connected* at the *connection point* are included. This is a simple definition, which avoids the difficulties that can be caused by a “deeper *connection asset*” policy where *assets* may change from *connection* to becoming part of the *transmission network*.

Consequently entry and exit *assets* include only station *assets*, including *transformers* which are used to *supply load* at the interface between *network users* and the *transmission network*.

However the *network service provider* may require the *network user* to meet all the *network charges* for radial *transmission lines*.

Transmission lines connecting *electric power producers* to the *network service provider’s assets* may be *assets* of the *electric power producer*. Where such are owned by the *network service provider* they are to be treated as *connection assets*.

Some station establishment and building costs are to be recovered through entry and exit charges. Treatment of these costs is covered in the following section.

S5.2.2.1 Station establishment and buildings

The majority of station establishment costs are included in the *transmission network* category. For example the cost of a circuit breaker includes associated *busbars* and isolators, secondary *plant* including remote control and secondary equipment, civil works, design installation and commissioning and project administration.

Additional station establishment costs includes only the civil works, roads and fences required for the establishment of the station while buildings include only the common station equipment and *facilities*. These costs are to be recovered through *connection charges*.

In cases where a substation does not *supply any load* (i.e. either a switching station or a transformation station between two *transmission* levels) then these station establishment and building costs should be allocated on a simple pro-rata basis to each circuit breaker which terminates a line or transformer at the station and will therefore be included in the node to node costs of the *transmission network*.

For example an existing station which provided transformation only between two *transmission voltage* levels could be extended to *supply load* in which case the associated additional station establishment costs would be allocated to the *connection* category. Alternatively an existing station which only supplies *load* may be converted by the addition of transformation between *transmission* levels. In this case station establishment costs would be allocated to *common service*.

Station establishment costs for existing stations which provide a dual purpose shall be allocated as *connection costs*.

S5.2.2.2 Summary of connection assets

The following sections summarise the allocation of specific *assets* to the *connection asset* category:

S5.2.2.2.1 Electric power producer switchyards(a) Entry (*connection assets*)

- (1) *Transmission* switchgear and associated *plant* used for *connection* of *generator transformers*;
- (2) Station establishment and buildings.

(b) Shared *network*

- (1) All switchgear for termination of *transmission lines* from the station.

S5.2.2.2.2 Load point substation(a) Exit (*connection assets*)

- (1) All switchgear at the subtransmission *voltage* level (i.e. feeder circuit breakers and subtransmission bus-tie circuit breakers and isolators);
- (2) All *transformers* which *supply* the subtransmission *voltage* level, and associated switchgear at both the *transmission* and subtransmission *voltage* level;
- (3) Station establishment and building costs;
- (4) Any bus-ties at the *transmission voltage* level; and
- (5) *reactive plant* installed for *power factor* correction.

Treatment on a case by case basis may be necessary for any specific situations which are not accommodated by these general rules.

S5.2.2.2.3 Meters

Metering installations on *network user* feeders will be treated as *connection assets*.

S5.2.2.2.4 Land

Land at stations which *supply load* or *connect electric power producers* will be treated as part of the *connection assets*. This will be site-specific; that is, the specific value of the land at each station will be included with the value of the station for charging purposes.

S5.2.3 TRANSMISSION NETWORK

The remaining *assets* are included as *transmission network assets*. This category includes all elements of the *network* which provides *transmission service* on a locational basis and forms the majority of the costs. The allocation of the *transmission network* costs involves determining the flow imposed on each *asset* by each *network user* and sharing the costs accordingly. This approach means that the costs of all *transmission network assets* has to be represented between nodes, i.e. all relevant station costs have to be allocated to *electric supply lines*.

This is achieved by including those station *asset* costs involved in terminating and switching each line at each end. This requires the cost of circuit breakers and terminations to be included with the line cost in order to represent a “node” to “node” cost.

Where breaker and a half switching arrangements are in place it will be necessary to split the costs of the “centre” circuit breaker between two circuits.

The *transmission network assets* include:

- (a) *transmission lines*;
- (b) switchgear (circuit breakers and isolators) on *transmission lines* and *auto-transformers* which are part of the *transmission network* and are switched at the station including associated *busbar* work and control and protection schemes;
- (c) auto-transformers which transform *voltage* between *transmission* levels;
- (d) any dynamic *reactive plant* and associated switchgear and transformation regardless of *voltage* level;
- (e) all existing *static reactive plant* and associated switchgear;
- (f) all system controls required for monitoring and control of the integrated *transmission system*. This includes remote monitoring and associated communications, *load shedding* and special control schemes and *voltage* regulating *plant* required for operation of the system.

SCHEDULE 5.3 - CATEGORIES OF DISTRIBUTION NETWORK COST

This schedule 5.3 describes how the *distribution network* costs may be formed from the revenue requirements as determined by *network owners*. It describes the *asset* categories which may be used, and defines the manner in which the *assets* may be categorised. It also indicates how total costs could be allocated between excluded *distribution service* categories and the prescribed *distribution service* categories of *connection*, *distribution use of system* and *common service*.

The *aggregate annual revenue requirement* of the *network* can be separated into three components:

- (a) costs which relate to the provision of *assets* to provide service to the overall system and any non-asset related costs which may not be appropriate to allocate to individual parts of the system (called *common service*);
- (b) the cost of providing *assets* which are fully dedicated to the *supply* of a single *consumer* or group *connected* at a single point within the *network* (called *connection assets*); and
- (c) *assets* which are shared to a greater or lesser extent by all *users* across the system and can be identified as related to a specific part of the system (*distribution use of system assets*).

The *aggregate annual revenue requirement* of the *network* shall exclude costs which relate to the provision of excluded *distribution services* and unrelated business activities including but not limited to costs in respect of *energy* trading and *generation*. It may be that some *connection assets* have been determined as providing excluded *distribution service* for a single *consumer* or group of *consumers connected* at a single point within the *network*.

Overhead type costs such as motor vehicles, construction equipment, computers, office equipment, software, operations and management of the business general overheads and other expenses that cannot be identified against *common service* *connection service* or *distribution use of system service* shall be allocated in a fair and reasonable way across all of these services.

S5.3.1 COMMON SERVICE COSTS

The *common service* cost category includes all the costs which cannot be allocated to *users* on a location basis, i.e. they cover those costs which provide equivalent benefits to all *users* within the *network* without any differentiation of their location. These costs are usually applied to *users* on a postage stamp basis.

There are two types of costs to be included in the *common service* category:

- (a) the cost of *assets* which provide a *common service*; and
- (b) the cost to the *network owner* of providing non-asset related services to *users*.

S5.3.1.1 Assets which provide common service

Common service is provided by *network assets* that can include, but are not limited to.

- (a) *power system* communications networks;
- (b) control systems;
- (c) *control centres*;
- (d) dynamic reactive control *plant*;
- (e) *static reactive plant*;
- (f) spare *plant* and equipment including that installed at *substations*;
- (g) fixed *assets* such as buildings and land that are not associated with substation or line easements, e.g. head office buildings, land for future stations etc.; and
- (h) *load* control signalling equipment in *substations* and on *consumer* premises.

S5.3.1.2 Non-asset related common service costs

The non-asset related *common service* costs can include but are not limited to the following:

- (a) *network* switching and operations; and
- (b) *network* planning and development.

Again, with these expenses only the *network owner*'s share of each category should be included into the total *common service* cost pool.

The remaining *network assets* are divided into two categories, *connection assets* and *distribution use of system assets*.

S5.3.2 CONNECTION ASSETS

The *connection asset* costs are recovered from the *consumers* who benefit from them and require no complex analysis to determine the sharing.

Connection assets are those *assets* (including individual *assets* within a station) which provide *supply* to only those *consumers* connected at the *connection point*. This simple definition, avoids the difficulties of *assets* changing from *connection* to becoming part of the *distribution use of system*.

- (a) Consequently *connection assets* would typically include the following:
 - (1) service lines plus meters for domestic *consumers*;
 - (2) service lines, meters, dedicated *distribution transformers* and associated switchgear for medium size commercial and industrial *consumers*; and
 - (3) *high voltage lines* and *plant* for major commercial and industrial *consumers*.

(b) The *asset* related costs of *connection assets* that have been:

- (1) provided by the *consumer*;
- (2) that portion of the *asset* provided by capital contributions from a *consumer*; and
- (3) provide *consumer connection* through excluded *distribution service*

may be excluded from the *aggregate annual revenue requirement* and/or price cap level of the *distribution network service provider* by the *Commission*.

The examples below highlight some of the issues associated with *connection assets* and recommended approaches in each case. The philosophy adopted is to assign as *connection assets* those *assets* that can be reasonably considered as being fully dedicated to the use of the *consumer*.

Example 1

Domestic Consumer in Suburban Area

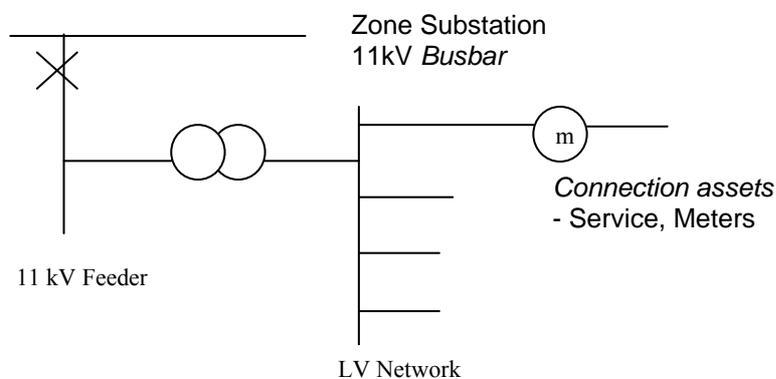

In this case there is virtually no choice, that is, the *connection service* is the LV service lines plus meters, and all upstream *network* (LV mains, *distribution transformers* etc.) is the *distribution service*. The *distribution network coupling point* (boundary of *connection service* and *distribution service*) is the junction of the service mains and the LV mains. The *connection point* is the *asset* boundary between the service main and the *consumer's* electrical installation

Example 2**Domestic Consumer in Rural Area (5 kVA)**

- Single *consumer* on a spur, dedicated *distribution* transformer

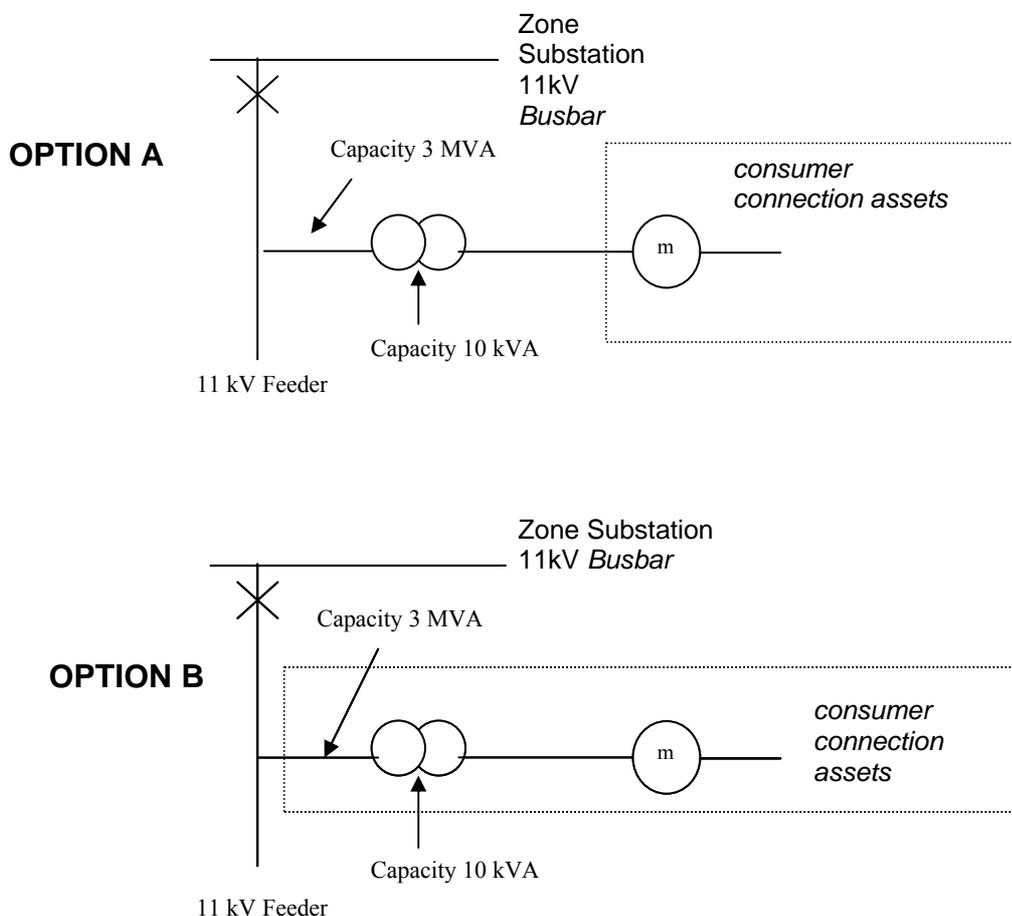

The 11 kV spur line has a large capacity compared to the expected *consumer* maximum demand. The *connection* charges associated with this *asset* would be abnormally high for a *consumer* of this size if this and the *distribution* transformer were included as *connection assets*.

Another important consideration is that any capital contribution policy is not necessarily related to a *connection asset* policy. That is, capital contributions may be sought from the *consumer* for installation of parts of the *distribution service*. In this case, a contribution may be sought for part or all of the cost of the 11 kV spur line plus the *distribution* transformer. This does not mean that these *assets* need be considered as *connection assets*. Option A is often utilised as it places the *connection asset* charges for this *consumer* on an equal basis with all other domestic *consumers*. Inequities in the cost of *supply* are managed by seeking capital contributions as required.

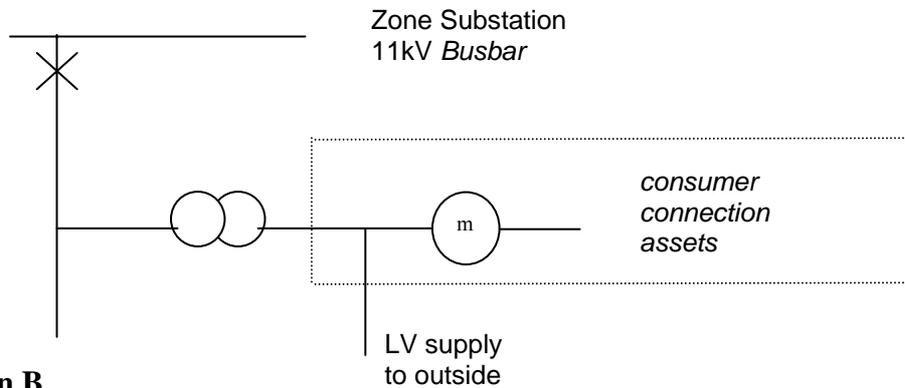
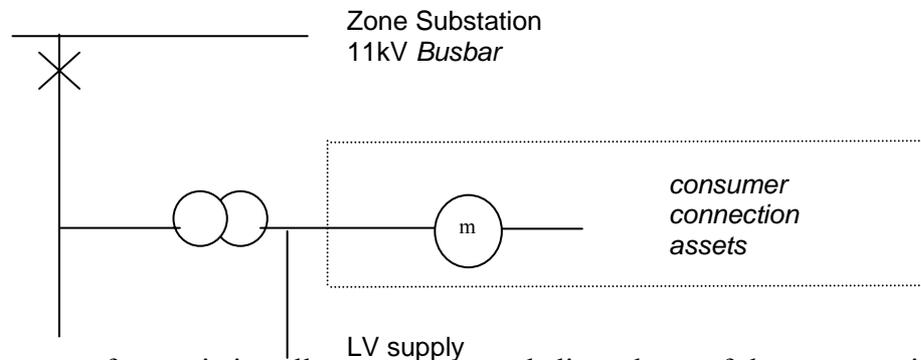
Example 3**New Commercial/Industrial Consumer - 250 kVA maximum demand****Option A****Option B**

In this case a transformer is installed for the dedicated use of the commercial and industrial consumer. In option A, the transformer (and associated protection), the service and the metering are considered as the *connection asset*. The alternative option B has the *connection assets* as only the LV service plus the metering, due to the shared use of the *distribution* transformer. In this case an important issue arises as to the extent of shared usage. In this case the outside LV supply is for backup only and the commercial and industrial consumer has a demand of above 80% of transformer capacity.

Option A is often used since the *asset* is essentially dedicated to the use of the consumer and the backup provided by the LV interconnection works to the mutual benefit of the consumer and/or the general LV network. If the LV supply fed other consumers on the network, then option B may be used since the transformer is a genuine shared *asset*.

Under option A, the *distribution network coupling point* is the tee point where the 11 kV spur joins the *distribution network*. The *connection point* is past the LV metering point on the *asset* boundary.

Example 4

Commercial and Industrial Consumer – 3 MVA maximum demand, requires 100% backup capability on the 11 kV feeder plus three 1500 kVA transformers for added security.

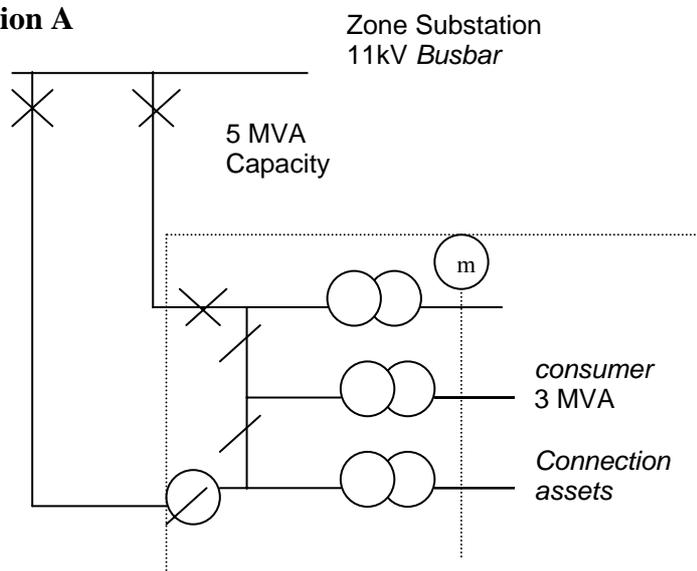
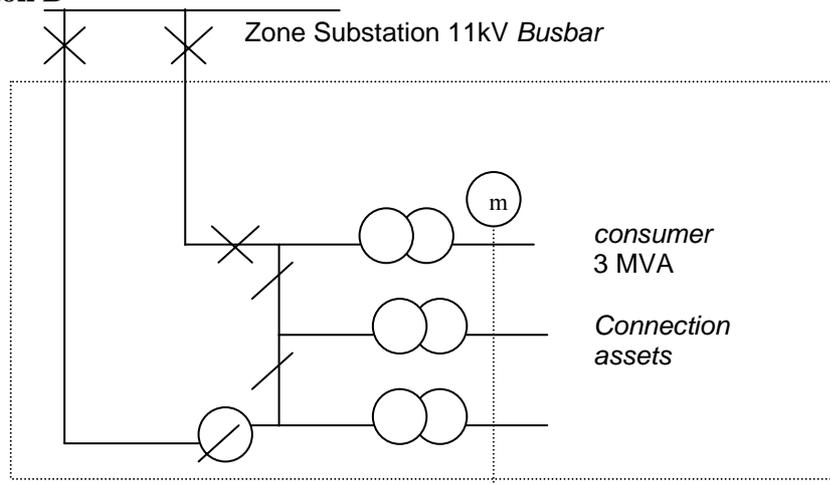
Option A**Option B**

In this example, option A reflects the shallow policy with *transformers* and associated switchgear as *connection assets* and option B reflects the requirement of the *consumer* to have 100% feeder backup capability. Selecting option B may result in the feeder *asset* being poorly utilised which is not appropriate. If a deep *connection asset* policy was chosen, then several *consumers* in the feeder ring could share the total *connection assets*. This may work but would be difficult to administer when demands changed or when *consumers* were added to or subtracted from the ring.

Option A is simpler and addresses the issue of the *consumer* requiring three 1500 kVA *transformers*. These *connection assets* can be provided on an agreed basis between the *network owner* and the *consumer* and provided the *consumer* pays an agreed return on those *assets* there is no problem. The *consumer* is paying the full cost for the improved security of *supply* from the extra transformer. The issue of backup feeder capacity for the *consumer* could be resolved by a capital contribution made by the *consumer* to the *network owner* for retaining spare capacity in the second feeder and/or constructing it initially.

Under option A, the *distribution network coupling point* is the HV switchgear. The *connection point* is past the LV metering point, on the *asset boundary*.

Example 5

CBD Consumer – 5 MVA

OPTION A

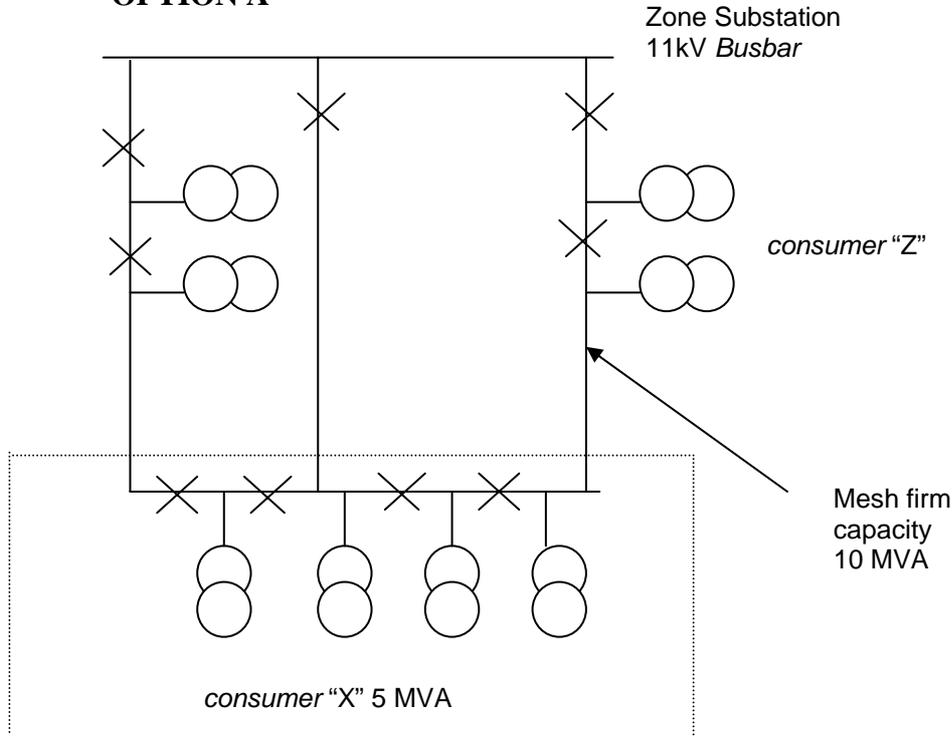

OPTION B

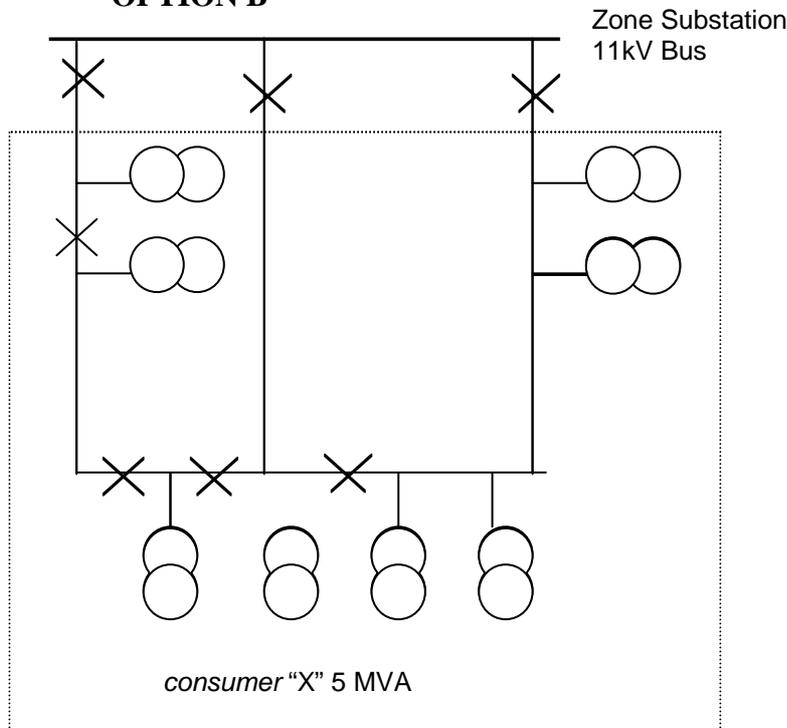

This is very similar to example 4 in that option A is the shallow policy including only local *consumer* equipment and option B includes the total mesh. Again option A is favoured to avoid the complication associated with determining charging proportions for option B, particularly with *consumers* being added or subtracted. The *network*

owner may choose to retain ownership of the circuit breakers to ensure operational integrity of the mesh but the whole substation could still be classified as *connection assets*.

Example 6

Major Industrial Consumer, 10+ MVA

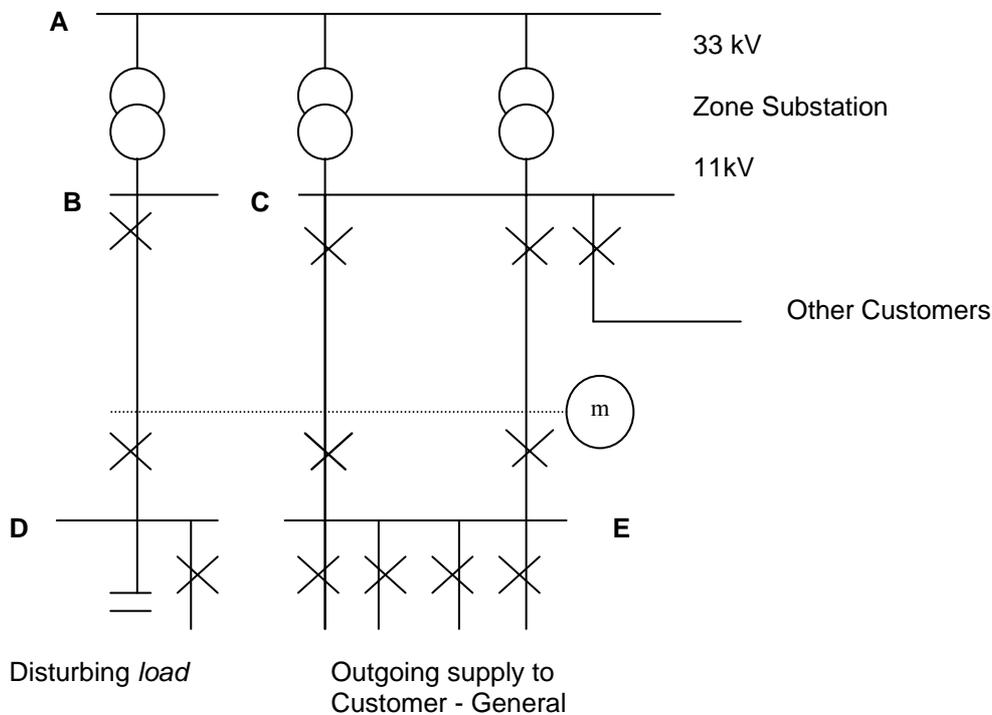

In this case part of the *consumer load* is supplied from *busbar C* at the zone substation and the remainder (a *disturbing load*) is supplied from a dedicated 33/11 kV transformer to reduce the impact of the *disturbing load*. Other *consumers* share the use of *busbar C* with the *consumer*. Several options exist for treatment of this situation as follows:

- (1) Treat the *consumer* as having a *distribution network coupling point* at 11 kV at *busbars B* and *C*. The 11 kV feeders from *B* to *D* and *C* to *E* are declared as *connection assets* and the *consumer* is charged for the *distribution service* (upstream shared *network*) at an 11 kV rate. The *connection point* is the *asset boundary* at *busbars D* and *E*.
- (2) Treat the *load* supplied from *busbar D* and the *load* supplied from *busbar E* as separate situations. That is, for the *load* on *busbar D* the *connection assets* could be treated as all *plant* between *A* and *D* with *A* as the *distribution network coupling point*. This part of the *load* would be given a *distribution service price* at a 33 kV rate. The *load* supplied from *E* could be treated as per option 1 with a *distribution network coupling point* at *C*, *connection assets* between *C* and *E* and an 11 kV *distribution service rate*.
- (3) The final option would be to adopt a shallow *connection asset* approach with the *distribution network coupling points* at *busbars D* and *E*. The *distribution service prices* could then be based on a standard 11 kV rate or if zonal pricing was adopted, a separate pricing zone could be adopted for the *supply to busbar D*. The separate pricing zone could be used to reflect differences in cost of *supply* to the *busbar D* *load*. This zonal pricing approach may be appropriate if for example several large *disturbing loads* collected at *busbar D*.

Another point of note in this example is the treatment of the series or shunt capacitor at busbar D. The poor *power factor load* at D necessitates the use of the *capacitor bank* to minimize losses and investment in *plant* between A and D. The capacitor should be treated as a *connection asset* in this case since it is required specifically for one *consumer* as opposed to most substation capacitors which are for general *network reactive power* requirements and are treated as *common service assets*.

Example 7

Major Industrial Consumer, 20+ MVA

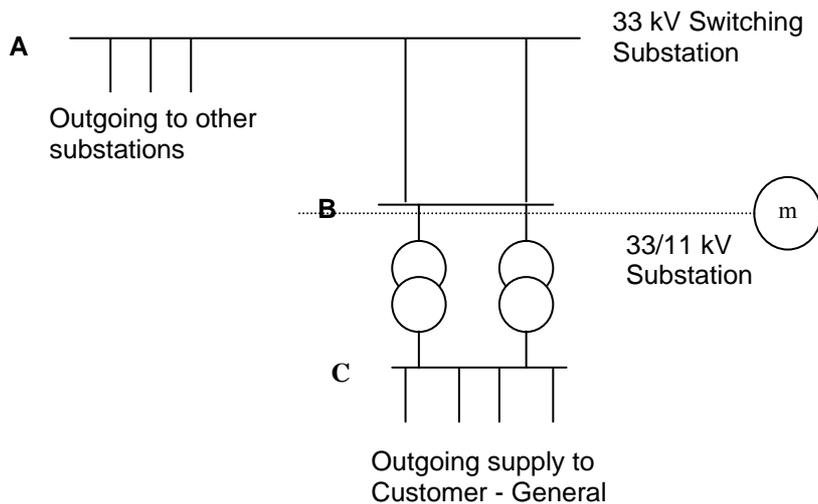

In this case the 33 kV feeders from A to B and the 33/11 kV substation are fully utilised by the *consumer load*. The choices for location of the *distribution network coupling point* are A, B and C. A is favoured in this case since the feeders and substation are fully utilised and dedicated for the use of the *consumer*. If either the feeders or the 33/11 kV substation could be shared in future then this would be a strong argument for shifting the *distribution network coupling point* closer to the *consumer*. In this case with the *coupling point* at A the *consumer* would receive a *distribution network service* at the 33 kV rate.

S5.3.3 DISTRIBUTION USE OF SYSTEM SERVICE

The remaining *network assets* are included as *distribution use of system assets*. This category includes all elements of the *network* which provides *use of system* service and forms the majority of the costs. The *distribution use of system assets* would typically include:

- (a) *distribution* lines including all poles and associated hardware;
- (b) terminating switchgear (circuit breakers and isolators) including associated protection and controls;
- (c) *transformers* between *distribution voltage* levels;
- (d) switchgear for above *transformers*;
- (e) underground cable systems including conduits and trenching;

The costs associated with *distribution use of system assets* are to be allocated on a usage basis and pricing structures include *voltage* levels, *consumer* classes and zones as required.

S5.3.4 OTHER CONSIDERATIONS

S5.3.4.1 Reactive plant

Reactive plant is provided for system reasons and is to be treated as a *distribution network asset*.

Reactive plant installed at the *distribution voltage* level of *distribution* stations should be charged as *distribution network assets* through application of a *common service price* unless it is clearly evident that such *plant* has been provided to meet the local reactive requirements of one or more *consumers connected* at that station in which case it may be charged as a *connection asset*.

S5.3.4.2 Station establishment and buildings

The majority of station establishment costs are included in the *asset* valuation for major *plant* items. For example the cost of a circuit breaker includes associated *busbars* and isolators, secondary *plant* including remote control and secondary equipment, civil works, design installation and commissioning and project administration.

S5.3.4.3 Meters

Metering installations for *consumers* will be treated as *connection assets* in accordance with the provisions outlined in Chapter 4 of the *Code*.

S5.3.4.4 Land

Land at stations which *supply* specific *consumers* or *connect embedded generators* will be treated as part of the *connection assets*. This will be site-specific; that is, the specific value of the land at each station will be included with the value of the station for charging purposes.

S5.3.4.5 Embedded generation

Embedded generators can in some circumstances provide significant benefits in certain parts of a *distribution network*. An example will highlight some of the issues.

A remote *load centre* is currently supplied from two existing 33 kV feeders. The maximum demand of the *load* is 20 MW and it is increasing steadily. Within 5 years a third 33 kV circuit will be required as will *substation reinforcement works* in later years. Through normal supply side planning this would require a \$5M capital injection in 2000 and a further \$5M in 2005. The options to be considered in this case include:

- (a) supply side *reinforcement*;
- (b) a DSM project incorporating both curtailable and *interruptible loads*;
- (c) *embedded generation*.

In this case the injection of local *generation* at the *load centre* would provide substantial loss reduction, long deferrals of the capital program and possible reliability improvements. An injection of 10 MW reliable *generation* would be appropriate initially. The key considerations from a *network pricing* perspective are as follows:

- (a) **Reliability** - for the *generation* to be an acceptable option the reliability of the *generator* would need to be assured. This could be achieved through suitable contract arrangements, a joint venture between the *network owner* and the *electric power producer* or combination of the *generation* with some existing *load* so that the *load* could be interrupted if the *generation* failed. The *generation* is most critical during *network contingencies* and reliability

considerations should include recognition of the *generation* configuration (e.g. multiple sets) and possible common failure modes.

- (b) **Network prices** - *network* prices would be broken into the three components as shown below.
- (1) *Common service* charges would generally be nil as under the *Code* all *common service* costs are allocated to *consumers*.
 - (2) *Connection service* charges would be determined based on the specific *connection asset* requirements.
 - (3) *Distribution service* charges are negotiable between the *network owner* and the *electric power producer*. The charges (or payment) need to reflect the benefit available to the *network owner* from the *embedded generation*. This will depend on:
 - (i) the sizing of the *generation* relative to the capacity and capability of the local *network* into which the *generation* is being *connected*;
 - (ii) the reliability of the *generation* and hence the ability to defer *reinforcement works* while providing an overall acceptable *consumer* reliability;
 - (iii) the degree to which any benefits to the *network* might accrue from the *generation* are shared between the *network service provider*, the *electric power producer* and other *network users*.

In this case, if the *generation* was very reliable and the capital program was deferred by several years then a payment to the *electric power producer* for some of the deferral value could result. The long run marginal cost (benefit) of the shared *network reinforcement* represents the upper limit of payment to the *electric power producer*.

As a general principle, commercial arrangements shall be made with *electric power producers* and this may include a competitive tendering process to ensure equal opportunity for other *electric power producers*. For example, a statement of opportunity for the area concerned could be issued with an invitation to bid for *generation* capacity in the area. This would facilitate free market forces providing the optimum outcome for the *network* business and existing *network consumers*.

S5.3.5 EXCLUDED DISTRIBUTION SERVICES

Services and activities that the *Commission* may define as excluded *distribution service* may include but are not limited to the following:

- (a) the wheeling of electricity not consumed in the *distribution network service providers'* system (i.e. on behalf of another *distribution network service provider*);
- (b) new *connection* and *reinforcement* of existing *connection* to the *distribution network*;
- (c) services (including *metering*, *electric supply lines* or *electrical plant*) for the specific benefit of any *network user* requested by that *network user* and not made available by the *distribution network service provider* as a normal part of *prescribed distribution service* to all *consumers*. These services can include:
 - (1) charges for moving mains, services or meters forming part of the *distribution network* to accommodate extension, redesign or redevelopment of any premises;

- (2) the provision of electric *plant* (i.e. mobile *generators*) for the specific purpose of enabling the provision of top-up or standby supplies of electricity; and
- (3) the provision of prepayment meters to *consumers*, but only to the extent that the charge for the provision of those meters exceed charges for the provision of standard meters for such *consumers*;
- (d) the relocation of *electric supply lines* and *plant* and the carrying out of associated works pursuant to any statutory obligations imposed on the *distribution network service provider*;
- (e) charges for temporary supplies;
- (f) capital contributions for new works and *reinforcements*;
- (g) charges for reserve and duplicate *supply*;
- (h) charges for supplies with higher quality and reliability standards than required by general practice;
- (i) charges for *connection points* requiring more than the least overall cost, technically acceptable *assets*;
- (j) charges for *distribution services* and system *reinforcement* required to receive *energy* from an *embedded generator*;
- (k) charges for *electric power producer* access for *embedded generators* under clause 3.5;
- (l) charges for non-compliance with the *connection agreement*, including but not limited to *reactive power*, *power factor*, harmonics, *voltage* dips and test *supply* requirements;
- (m) charges for multiple *connection points* to a single property not recovered through *prescribed distribution service* prices;
- (n) charges for public lighting;
- (o) charges for provision of *metering* to a standard in excess of that required for the billing of *prescribed distribution network service*.

SCHEDULE 5.4 - PRINCIPLES FOR NETWORK PRICING

S5.4.1 COST REFLECTIVE PRICING

Network charges should in principle be cost reflective. This is to facilitate the competitive market, by providing equitable access to the *network* and ensuring that appropriate investment in the *network* takes place in the longer term.

It is intended that all *electric power producers* and *consumers* be charged on a consistent basis, in accordance with their use of *network assets* and taking into account the impact of *network constraints*.

S5.4.2 NON-DISCRIMINATORY PRICING OF NETWORK SERVICES

Network pricing should provide non discriminatory access to the *network*. This implies a common approach for all *Code Participants*, no matter where they are located or whether they participate or not in the competitive market trading. Actual prices at different locations will differ, because of the *network* configuration and patterns of use. In this way, prices will equitably recover the costs of the *network*.

Network pricing should be based on the location in the *network* and the *assets* employed in providing *transmission* or *distribution services*. The price for each *Code Participant*

should be influenced by the location in the *network* and the *assets* employed in providing *transmission* or *distribution service*.

S5.4.3 COMPATIBILITY WITH INDUSTRY TRADING ARRANGEMENTS

The *network* pricing proposals should be compatible with the electricity industry design proposals to encourage and facilitate the development of these arrangements.

The pricing approach proposed is independent of any contract arrangements that *Code Participants* will enter into for *energy* trading. In return for the payment of a *connection* and *use of system* fee to the local *network owner*², the *Code Participant* is entitled to enter into *energy* trading arrangements with any other *Code Participant*.

S5.4.4 NETWORK PRICES FOR ECONOMICALLY EFFICIENT INVESTMENT

Network prices should provide signals to optimise the cost of *network* development in order to minimise the cost of development and operation of the industry.

It should be recognised that the above objectives of non-discriminatory pricing (leading to the equitable recovery of existing costs) and economically efficient pricing for new investment in the *network* are to some extent incompatible. The challenge is to devise a method of *network* pricing which meets both.

S5.4.5 PUBLISHED AND TRANSPARENT NETWORK PRICES

Prices for *transmission networks* and *distribution networks* should be transparent and may be published in order to provide pricing signals to *Code Participants*.

S5.5 TRANSMISSION SYSTEM PLANNING AND SECURITY STANDARD

S5.5.1 Introduction

The *transmission system* Planning and Security Standard is a formulation of the guidelines for planning and expansion of *transmission system* in Kenya. The scope of this standard covers:

- (1) System studies.
- (2) Assessment of the system data.
- (3) Assessment of *generation* availability.
- (4) Planning criteria.
- (5) Security conditions required for maintaining specified degree of reliability.
- (6) Criteria for substation planning.
- (7) Estimation of *reactive power* compensation required.

S5.5.2 Transmission planning

- (a) The long and medium term perspective planning involves an integrated approach for evacuating power from different *generating stations*, irrespective of their ownership, and delivering it to the beneficiaries over an optimally designed power *transmission system* with reliability, security and economy. The *power system* in

² For the purpose of this schedule only the term "*network owner*" is considered a generic term covering the overall responsibilities of the network entities, i.e. *asset* maintenance, operation, planning and pricing. In some jurisdictions responsibilities for these functions may be split across more than a single *network owner* where the *asset* owner is not the service provider.

Kenya has to be planned in such a manner that the power received from all the power *plants*, can be transmitted without *constraints* to different beneficiaries, as per their allocated shares, maintaining a reasonably good *voltage* profile, stability conditions and redundancy criteria.

- (b) The *transmission* planning should be developed to achieve a strong co-ordinated *power system* for the national *grid*, where substantial inter-regional transfers can be achieved with optimised utilisation of available *generation*. The *transmission* planning shall also provide a high standard of *supply* to beneficiaries with acceptable degree of reliability and at reasonable cost. The criterion should be that even under the conditions of the specified outages considered in the security standards; the power flow should not be affected. The *transmission* planning should keep in view the long term future load growth also and the *transmission lines* and *substations* shall be so planned that the same can be upgraded when necessary in future, with minimum interruptions and modifications.
- (c) For the purpose of reducing inventory, procurement time and installation time, the *Transmission Licensee* shall adopt standardised designs as far as possible for *transmission line* towers, structures for *substations*, substation lighting, control room lighting and ventilation, substation earthing, standardised specification for line materials, *transformers*, substation equipment, cables, *busbar* accessories, insulators, hard wares etc.
- (d) The possibility of providing adequate *transmission interconnections* within the Kenya *grid* as well as between regional *grids* has to be considered wherever economically feasible considering all economic *energy/capacity* interchanges subject to trade off between new *generation* and cost of *transmission*. The modern Flexible AC *Transmission system* (FACTS) based on thyristor based controls, HVDC, fast controllable phase shifters etc., have also to be considered wherever economically feasible and/or *constraints* of corridor exist for construction of new *transmission lines*.

S5.5.3 System studies

- (a) The *loads* to be supplied from various *substations* at steady state within the limits of declared *voltage* and acceptable frequency of 50 Hz and the future load development has to be assessed after making a detailed study of the present conditions and a load survey. A reasonable estimate of *transmission* losses shall also be included to arrive at peak *generation* capacity. The system is to be further evolved based on the following *power system* studies:
 - (1) Load flow
 - (2) Optimal power flow for various conditions.
 - (3) Short Circuit
 - (4) System stability - Steady state
 - (5) System stability - transient
 - (6) Studies to determine switching/temporary over *voltages*
 - (7) Other studies as required.
- (b) These studies require suitable computer programs. Mathematical models of *generation*, *transmission* and load shall be prepared separately for each year of a plan period assessing probable year of commissioning of particular *electric supply lines*, *substations*, additional *transformers* in existing *substations* etc, based on the

system *network* for the year in question with all the *generation* and load *busbars* properly located. Inter connections with neighbouring states at 300kV and 220kV levels shall be incorporated as appropriate. Appropriate equivalent circuit models shall be used to take into account the fault level at the *interconnection* points. The *interconnection busbars* shall be modelled by representing significant and necessary portions of the neighbouring *networks* to represent realistically the MW and MVA imports/exports. Studies shall be carried out both for peak load and minimum load conditions.

S5.5.4 System data

To arrive at a reasonably accurate load forecast and for conducting studies, compilation and updating of system data is absolutely necessary. The planning study should begin with the proper representation of the existing *system* to establish the base case and to validate the model. The results obtained for the existing *system* should be verified with the meter readings, logged data at the *substations* and the state load *dispatch* centre to closely match the same. The *system* parameters have to be updated incorporating the correct data whenever addition or modifications have been carried out on the *system* either by the survey of the correct line lengths and conductor configurations or preferably by direct measurement of the line impedance values whenever and wherever possible. All the *system* data shall be the same for both the planning standards and operation standards. The *loads* shall be modelled at 220 kV, 132 kV and 66 kV *busbars*. The annual minimum load shall be taken as a percentage of annual peak demand as prevailing in the base year.

S5.5.5 Generation

For peak load conditions, different *generation* mixes of various power stations, resulting in an optimal average cost shall be determined by conducting the required number of load flow studies, or using well developed computer program packages to determine the same. For the minimum load conditions, the *generator* which “must run”, shall be used in conjunction with the most economical *generation*. The *generation dispatch* for the purpose of sensitivity analysis corresponding to a complete closure of a major generating station shall be worked out by increasing the *generation* at other stations to the extent possible keeping in view the maximum likely availability at those stations, cost of power, etc. *transmission constraints* will have to be addressed properly. The *transmission system* being planned shall consider the adequacy of the *network* required to transmit power even under various outage conditions specified in the security standards. Studies shall be repeated for normal and contingency conditions as required in the security standards.

S5.5.6 Planning Criteria

- (a) KPLC “Manual on Transmission Planning Criteria” shall be adopted with modification as stated below, particularly with reference to steady state *voltage* limits and security standards for withstanding outages.
- (b) The *transmission* shall be planned in such a way to maintain steady state *voltage* within limits as stated below:

| Nominal <i>system voltage</i> kV-rms. | Maximum kV- rms | Minimum kV- rms |
|---------------------------------------|-----------------|-----------------|
| 66 | 72.5 | 60 |
| 132 | 145 | 120 |
| 220 | 245 | 200 |
| 330 | 350 | 300 |
| 400 | 420 | 360 |

- (c) **Line Loading Limits:** The permissible line loading limits shall conform to KPLC’s “Manual on Transmission Planning Criteria”. The over loading and under loading of *electric supply lines* shall be decided accordingly.
- (d) Options for *reinforcing* of the *transmission network*
- (1) Addition of new *transmission lines* to avoid over loading of existing system (wherever three or more circuits of the same *voltage* class are envisaged between two *substations*, the next higher *transmission voltage* may be considered).
 - (2) Upgrading of the existing *transmission lines* such as raising height of conductor supports and/or switch over to insulated cross-arms to facilitate change over to higher *voltage*, if the tower design so permits.
 - (3) Reconductoring of the existing *transmission line* with higher size of conductors or with AAAC (All Aluminium Alloy Conductor) or use of bundled conductors.
 - (4) The choice shall be based on cost, reliability, right of way requirements, *energy* losses, down time, etc.
- (e) All single circuit *electric supply lines* shall be planned with double circuit towers, wherever technically feasible, to enable future expansion without right of way problems.

S5.5.7 Security standards

- (a) **Steady State Stability:** The system shall be planned to withstand satisfactorily without any load shedding or altering the *generation* at power stations for at least, any one of the following outage conditions:
- (1) Outage of any tower in a double circuit *transmission line*.
 - (2) Two Circuits of 66 kV or 132 kV or 220 kV *electric supply lines*.
 - (3) One circuit of 330 kV *electric supply line*.
 - (4) One interconnecting transformer.
 - (5) One largest capacity *generator*.
 - (6) One inter-connecting line with neighbouring *grid*.
- (b) The above contingencies shall be considered assuming a pre-contingency system depletion (planned outage) of another 220 kV double circuit line or 330 kV single circuit *electric supply line* in another corridor and not emanating from the same

substation. All the generating *plants* shall operate within the limits as per their reactive capability curves and the *network voltage* profile shall also be maintained within the specified *voltage* limits.

- (c) **Transient Stability** The system shall be designed to maintain synchronism and system integrity under the following disturbances.
- (1) Outage of the largest size *generator* in the national *grid* or *interconnection* with neighbouring *grids*.
 - (2) A single line to ground fault on a 330 kV *electric supply line*, single pole opening of the faulted phase (5 cycles) with unsuccessful re-closure (dead time 1 sec) followed by 3 pole opening (5 cycles) of the faulted *electric supply line*.
 - (3) 400 kV double circuit *electric supply line*:
 - (i) When both the circuits are in operation, the *system* shall be capable of withstanding a permanent fault on one of the circuits followed by a three-pole opening (100-m sec.) of the faulted circuit.
[Explanation: - Single pole opening and unsuccessful auto-re-closure is not considered generally in long 330 kV double circuit *electric supply lines* since the re-closure *facility* is by-passed when both circuits are in operation, due to difficulties in sizing of neutral grounding reactors.]
 - (ii) When one of the circuits is under maintenance/outage the *system* shall be capable of withstanding a transient fault on the circuit in service.
 - (4) A permanent 3-phase fault with duration of 8-cycles on 220 kV or 132 kV or 66 kV *electric supply line* assuming three-pole opening.
 - (5) No stability studies for faults are required for radial *electric supply lines*.

S5.5.8 Substation planning criteria

- (a) For meeting a particular quantum of load the number of *substations* required depends upon the choice of *voltage* levels, the MVA capacity and the number of feeders permissible etc. The number of EHT *transformers*, interconnecting *transformers* shall also be considered in planning to take care of contingencies of planned/forced outages. The rupturing capacity of the circuit breakers shall have 20 percent margin to take care of increase in short circuit levels as the *system* grows. The following criteria can be adopted:

- (1) The capacity of any single substation at different *voltage* levels shall not normally exceed:

| | |
|--------|---------|
| 400 kV | 1000MVA |
| 330 kV | 500 MVA |
| 220 kV | 320 MVA |
| 132 kV | 150 MVA |
| 66 kV | 80 MVA |

- (2) Size and number of interconnecting *transformers* (ICTs) shall be planned in such a way that the outage of any single unit would not overload the remaining ICTs or the underlying *system*.
- (3) Size and number of HT / EHT *transformers* shall be planned in such a way that in the event of outage of any single unit, the remaining HT/EHT *transformers* would still *supply* 80% of the load. This has to be achieved in such a way that, with the *interconnection* of the adjacent *substations*, the load exceeding the capacity of the available *transformers* may be transferred on to them.

- (4) The rated rupturing capacity of the circuit breakers in any substation shall not be less than 120% of the maximum fault levels at the *substations*. (The 20% margin is intended to take care of increase in short circuit levels as the *system* grows). The minimum rated rupturing of capacity of switchgear at different *voltage* levels are as follows:

| | |
|--------|---------|
| 66 kV | 25 kA |
| 132 kV | 31.5 kA |
| 220 kV | 40 kA |
| 330 kV | 40 kA |
| 400 kV | 40 kA |

S5.5.9 Reactive Compensation

- (a) **Series or shunt capacitors** Reactive compensation shall be provided as far as possible in 132 kV *systems* with a view to meet the *reactive power* requirement of load close to the load points. In the planning study the series or shunt capacitors required shall be shown at 132/220 kV *busbars*.
- (b) **Shunt Reactors** Switch-able *shunt reactors* shall be provided at 330 kV *substations* for controlling *voltages* within the limits specified. The step changes shall not cause a *voltage* variation exceeding 5%. Suitable *line reactors* (switch-able/fixed) shall be provided to enable charging of 330 kV *electric supply lines* without exceeding *voltage* limits specified.

CHAPTER 6 SCHEDULING AND DISPATCH PROCESS**TABLE OF CONTENTS**

| | Page |
|---|------|
| 6.1 INTRODUCTION | 185 |
| 6.2 LOAD FORECASTING | 185 |
| 6.3 PROJECTED ASSESSMENT OF SYSTEM ADEQUACY | 186 |
| 6.3.1 Administration of PASA | 186 |
| 6.3.2 Short term PASA | 187 |
| 6.3.3 Medium term PASA | 188 |
| 6.4 DISPATCH | 189 |
| 6.4.1 Dispatch timetable | 189 |
| 6.4.2 Generation capacity | 189 |
| 6.4.3 Submission timing | 189 |
| 6.4.4 Generator dispatch information | 189 |
| 6.4.5 Network constraints | 190 |
| 6.4.6 Ancillary services constraints | 190 |
| 6.4.7 System reserve constraints | 190 |
| 6.4.8 Notification of constraints | 191 |
| 6.4.9 Dispatch inflexibilities | 191 |
| 6.4.10 Pre-dispatch schedule | 191 |
| 6.4.11 Dispatch instructions | 192 |
| 6.4.12 Failure to conform to dispatch instructions | 193 |
| 6.4.13 Dispatch related limitations | 194 |
| 6.4.14 Commitment | 195 |
| 6.4.15 De-commitment | 195 |
| 6.4.16 Generating plant changes | 196 |
| 6.5 ANCILLARY SERVICES | 196 |
| 6.5.1 Introduction | 196 |
| 6.5.2 Ancillary services not purchased by the System Operator | 196 |
| 6.5.3 Ancillary services contracting by the System Operator | 197 |
| 6.5.4 Ancillary services agreements | 197 |
| 6.5.5 Provision of ancillary services | 197 |
| 6.5.6 Performance testing | 198 |

CHAPTER 6 SCHEDULING AND DISPATCH PROCESS

6.1 INTRODUCTION

This Chapter of the *Code*, which deals with the scheduling and *dispatch* process:

- (a) applies to:
- (1) the *System Operator*;
 - (2) *electric power producers*;
 - (3) *public electricity suppliers*; and
 - (4) large *consumers*.
- (b) and has the aim that the continuously changing *demand* on the *grid* is met in the most economic manner. Consequently, *generators* shall, as far as practicable be put on *load* and loaded up in accordance with the least variable operation and maintenance costs inclusive of cost of fuel (where applicable) and consumables (hereinafter called “*operating costs*”) of producing electricity from each *generator*. Fixed costs are not taken into consideration. At any time the total *generating plant* with the least *operating costs* is used to meet the *demand* with a satisfactory margin.

6.2 LOAD FORECASTING

- (a) The *System Operator* shall produce (at the intervals indicated and in accordance with the timetable) an indicative *load forecast* for the periods indicated below:
- (1) each *day*, a forecast for the *day* ahead, such forecast divided into half-hourly *load forecasts*;
 - (2) each *day*, a forecast for 2 to 7 *days* (inclusive) ahead, the forecasts for each such *day* divided into half-hourly *load forecasts*; and
 - (3) every month, a forecast for the 24 months ahead of the *day* on which the forecast is produced, of a typical daily profile based on an estimated weekly *peak load* condition with allowances for *days* which are not *business days*.
- (b) These forecasts are to provide an indicative estimate of the total *generation* capacity required to meet the *forecast load* (called “*forecast load* (as generated)”), and an equivalent estimation of the *supply* required to be delivered to the *transmission network* and the *distribution network* (called “*forecast load* (sent out)”).
- (c) The following factors shall be taken into account in the development of the *load forecasts*, to the extent that such are relevant to the particular forecast:
- (1) the annual *load forecasts* and *load* profiles collected by the *System Operator* from all *Code Participants* as required by schedule 3.7, including *load* management expectations and expected sent-out electricity from *embedded generators*;
 - (2) historic *load* data, including *transmission* losses and power station in-house use of the generated output;
 - (3) weather forecasts and the current and historic weather conditions and pattern;
 - (4) the incidence of major events or activities which are known to the *System Operator*;
 - (5) official economic activity forecasts; and
 - (6) other information provided by *Code Participants*.

- (d) The *System Operator* shall develop a methodology to create the indicative *load forecasts*.
- (e) The *load forecast* to be adopted for the purposes of determination of short term capacity reserve and medium term capacity reserve requirements and the determination of *short term capacity reserves* and *medium term capacity reserves* will be in accordance with the *power system security and reliability standards*.
- (f) The *System Operator* will use the indicative *load forecasts* for processes such as the determination of the required levels of *short term capacity reserves*, *medium term capacity reserves*, the PASA assessments and *pre-dispatch schedules*.
- (g) The *load forecasts* produced by the *System Operator* shall be indicative only as the *System Operator* has no direct influence over *Code Participants* in their decisions about their level of *demand* and, accordingly, no *Code Participant* is entitled to claim any loss or damage from the *System Operator* as a result of any difference between *load forecasts* and actual *load*.

6.3 PROJECTED ASSESSMENT OF SYSTEM ADEQUACY

6.3.1 Administration of PASA

- (a) The *System Operator* shall administer short term and medium term projected assessment of system adequacy processes to be known as PASA.
- (b) The PASA is a comprehensive program of information collection, analysis and disclosure of short term and medium term *power system security* prospects so that *Code Participants* are properly informed to enable them to make decisions about *supply*, *demand* and outages of *transmission networks* in respect of periods up to 2 years in advance.
- (c) On a monthly basis the *System Operator* will:
 - (1) collect weather forecast information;
 - (2) collect and analyse information from all *electric power producers*, *public electricity suppliers* and *network service providers* about their intentions for (where relevant):
 - (i) *generation* and *transmission* maintenance scheduling;
 - (ii) intended *plant* availabilities;
 - (iii) water storage levels and *energy constraints*;
 - (iv) fuel situations;
 - (v) other *plant* conditions which could materially impact upon *power system security*; and
 - (vi) significant *changes* to *load forecasts* previously notified to the *System Operator*, for the following 24 months; and
 - (3) following analysis and assessment, publish information that will:
 - (i) assist *Code Participants* to plan any scheduled work on *plant*; and
 - (ii) inform the *Commission* of possible *power system security* problems.
- (d) The *System Operator* shall use his reasonable endeavours to ensure that he provides to *Code Participants* sufficient information to allow *Code Participants* to undertake maintenance and outage planning without violating *power system security*.

6.3.2 Short term PASA

- (a) The short term PASA shall be issued at least daily by the *System Operator* in accordance with the timetable.
- (b) The short term PASA covers the period of six *days* starting from the end of the *day* covered by the most recently published *pre-dispatch schedule* with a half hourly resolution.
- (c) The *System Operator* may publish additional updated versions of the short term PASA in the event of *changes* which, in the judgment of the *System Operator*, are materially significant and should be communicated to *Code Participants*.
- (d) The following short term PASA inputs are to be prepared by the *System Operator*:
 - (1) *forecast load* which is to include the most probable half hourly profile on the basis of past trends, *day* type and special events;
 - (2) reserve requirements determined in accordance with the *short term capacity reserve standards*; and
 - (3) anticipated *network constraints* known to the *System Operator* at the time.
- (e) The following short term PASA inputs are to be submitted by each relevant *Code Participant* in accordance with the timetable and shall represent the *Code Participant's* current intentions and best estimates of (relevantly):
 - (1) availability of each *generator* for each scheduling interval;
 - (2) *generator* synchronisation/de-synchronisation times for *generators*;
 - (3) projected daily *energy* availability for *energy constrained generators*; and
 - (4) anticipated *self-dispatch level* for each *generator* for each scheduling interval.
- (f) If the *System Operator* considers it reasonably necessary for adequate *power system* operation and the maintenance of *power system security*, *Code Participants* who may otherwise be exempted from providing inputs for the PASA process shall do so to the extent specified by the *System Operator*.
- (g) *network service providers* shall advise their planned *network* outages in accordance with the timetable which are to be converted to *network constraints* by the *System Operator*.
- (h) The *System Operator* shall prepare and publish the following information as short term PASA outputs for each scheduling interval:
 - (1) forecasts of the most probable *power system load* plus required reserve for the total *power system*;
 - (2) forecasts of *power system load* determined in accordance with the *power system security and reliability standards*;
 - (3) forecasts of the most probable *energy* consumption for the total *power system*;
 - (4) aggregate *generator* availability calculated by adding the following two categories:
 - (i) the capacity of *generators* which are able to operate at full capacity on a continuous basis to meet forecast *power system load*; and
 - (ii) an allocation of *generation* which cannot be generated continuously at the offered capacity of the *generator* for the period covered due to specified *energy constraints* or water storage levels; and

- (5) identification and quantification of:
- (i) any projected *violations* of *power system security*;
 - (ii) any scheduling intervals for which *low reserve* or *lack of reserve* conditions are forecast to apply; and
 - (iii) when and where *network constraints* may become binding on the *dispatch* of *generation* or *load*.
- (i) In the event that in performing the short term PASA the *System Operator* identifies any projected *low reserve* or *lack of reserve* conditions, then the *System Operator* shall use his reasonable endeavours to advise the relevant *public electricity suppliers* of any potential requirements during such conditions to shed *sensitive loads*.
- (j) The *System Operator* shall document the procedure he uses for preparation of the short term PASA and make it available to all *Code Participants* on a cost recovery basis.

6.3.3 Medium term PASA

- (a) The medium term PASA covers the 24 month period commencing from the *day 8 days* after the *day* of publication with a daily resolution, and shall be reviewed and issued every month by the *System Operator* in accordance with the timetable.
- (b) The *System Operator* may publish additional updated versions of the medium term PASA in the event of *changes* which, in the judgment of the *System Operator*, are materially significant and should be communicated to *Code Participants*.
- (c) The following PASA inputs are to be prepared by the *System Operator*:
- (1) *forecast load* which is:
 - (i) to indicate the most probable *peak load*, time of the peak, and daily *energy* on the basis of past trends, *day* type and special events including all anticipated *load*; and
 - (ii) an indicative half hourly *load* profile for each *day* type for each month of the year;
 - (2) reserve requirements determined in accordance with the *medium term capacity reserve standards* set out in the *power system security and reliability standards*; and
 - (3) *forecast network constraints* known to the *System Operator* at the time.
- (d) The following medium term PASA inputs shall be submitted by each relevant *Code Participants* in accordance with the timetable:
- (1) expected availability of each *generator* for each *day*; and
 - (2) weekly *energy constraints* applying to each *generator*.
- (e) *network service providers* shall advise the *System Operator* of planned *network outages* in accordance with the timetable.
- (f) The *System Operator* shall prepare and publish the following information in respect of each *day* covered by the medium term PASA:
- (1) forecasts of the most probable peak *power system load* plus required reserve for the total *power system*;
 - (2) forecasts of the most probable *energy* consumption for the total *power system*;

- (3) aggregate *generator* availability, calculated by adding the following two categories:
 - (i) the capacity of *generators* which are able to operate at full capacity on a continuous basis to meet *forecast load*; and
 - (ii) an allocation of *generation* which cannot be generated continuously at the nominated capacity of the *generator* for the period covered due to specified *energy constraints* or water storage levels; and
- (4) identification and quantification of:
 - (i) any projected *violations* of *power system security*;
 - (ii) any *days* on which *low reserve* or *lack of reserve* conditions are forecast to apply; and
 - (iii) when and where *network constraints* may become binding on the *dispatch* of *generation* or *load*.
- (g) The *System Operator* shall document the procedure he uses for preparation of the medium term PASA and make it available to all *Code Participants* on a cost recovery basis.
- (h) Each *electric power producer* shall provide to the *System Operator* all data available to him and reasonably required for modelling of the *electric power producer's generator(s)* and hydrological system to evaluate the medium term PASA.

6.4 DISPATCH

6.4.1 Dispatch timetable

The *System Operator* shall facilitate and operate the *dispatch process* according to the timetable which shall be determined and published by the *System Operator*.

6.4.2 Generation capacity

All *electric power producers* shall inform the *System Operator* of the following in accordance with the timetable:

- (a) the available capacity of each *generator* for each scheduling interval of each *day*;
- (b) two *days* ahead of each *day dispatch information* which includes the following information:
 - (1) a MW capacity profile that specifies the MW available for each of the 48 scheduling intervals in the *day*;
 - (2) estimated *commitment* or *decommitment* times;
 - (3) daily *energy* availability for *energy constrained generators*; and
 - (4) ramp rate *constraints*.

6.4.3 Submission timing

- (a) *Dispatch information* shall be submitted according to the timetable.
- (b) *Changes* to the MW quantities in the *dispatch information* may be made after the deadline in the timetable.
- (c) The submission of *dispatch information* to the *System Operator* shall be made using a communication system approved by the *System Operator*.

6.4.4 Generator dispatch information

- (a) The following requirements apply to all *dispatch information* which relates to *generators*:
 - (1) *dispatch information* shall contain the *electric power producer's* intended *self-dispatch level*, if any, for each scheduling interval;
 - (2) the *dispatch information* shall specify for each of the 48 scheduling intervals in the *day* a MW capacity for the intended *self-dispatch level*, if any, specified in whole MW and a MW/min ramp rate capability; and
 - (3) the MW quantities specified are to apply at the terminals of the *generator* or, with the *System Operator's* agreement, at any other point in the *electric power producer's* electrical installation or on the *network*.
- (b) The *dispatch information* may specify the daily *energy* available for *energy constrained generators*.
- (c) An *electric power producer* shall ensure that each of his *generators* is at all times able to comply with the latest *dispatch information* under this Chapter 6 in respect of that *generator*.

6.4.5 Network constraints

- (a) In accordance with the *System Operator's power system security responsibilities* and any other standards set out in Chapter 7, the *System Operator* shall determine any *constraints* on the *dispatch* of *generators* which may result from planned *network* outages.
- (b) The *System Operator* shall represent *network constraints* as inputs to the *dispatch process* in a form that can be reviewed after the scheduling interval in which they occurred.
- (c) The process used by the *System Operator* to derive the *network constraints* shall be clearly documented and made available to *Code Participants*.

6.4.6 Ancillary services constraints

- (a) The *System Operator* shall determine the quantity and nature of *ancillary services* which:
 - (1) have been provided or procured in accordance with the *System Operator's power system security responsibilities* set out in clause 7.3.1 or are otherwise available;
 - (2) are required to be managed in conjunction with *dispatch*; and
 - (3) may impose *constraints* on *dispatch*.
- (b) The provision of *ancillary services* identified by the *System Operator* under clause 6.4.6(a) is to be managed by the *System Operator* as part of the *dispatch process*.
- (c) The *System Operator* shall use his reasonable endeavours to ensure that *dispatch* of *ancillary services* is undertaken in a manner that maximises the total benefits for the *supply* of electricity.

6.4.7 System reserve constraints

The *System Operator* shall use his reasonable endeavours to ensure that the *dispatch process* meets all requirements for reserves as described in Chapter 7.

6.4.8 Notification of constraints

The *System Operator* shall publish the parameters used in the *dispatch process* for the modelling of *network constraints*, *regulating capability constraints*, *power system reserve constraints* and *ancillary services*.

6.4.9 Dispatch inflexibilities

- (a) If an *electric power producer* reasonably expects one or more of his *generators* to be unable to operate in accordance with *dispatch instructions* in any scheduling interval due to abnormal *plant* conditions or other abnormal operating requirements in respect of that *generator*, he shall advise the *System Operator* that the *generator* is inflexible in that scheduling interval and shall specify a fixed *loading level* at which the *generator* is to be operated in that scheduling interval.
- (b) Where an *electric power producer* advises the *System Operator* that a *generator* is inflexible in accordance with clause 6.4.9(a):
 - (1) he shall record and advise the *System Operator* of the reason why the *generator* is expected to be unable to comply with *dispatch instructions* and provide the *System Operator* with such substantiation of the reason that the *System Operator* may reasonably require;
 - (2) any *electric power producer* may request the *System Operator* to provide details of the stated reasons for the *generator* being declared to be inflexible as well as copies of any substantiating material provided to the *System Operator* and the *System Operator* shall provide the information requested.
- (c) Other than in scheduling intervals for which it has been specified by an *electric power producer* in the relevant *dispatch information* for a *generator* that the *generator* is inflexible, then the *System Operator* will *dispatch* the *generator* in accordance with the relevant *dispatch information* and the *dispatch process*.
- (d) *Electric power producers* may provide the *System Operator* with a *dispatch inflexibility profile* for one or more *generators*.
- (e) The *System Operator* shall use reasonable endeavours not to issue a *dispatch instruction* which is inconsistent with an *electric power producer's dispatch inflexibility profile*.

6.4.10 Pre-dispatch schedule

- (a) Each *day*, in accordance with the timetable, the *System Operator* shall prepare and publish a *pre-dispatch schedule* covering each scheduling interval for the next *day*.
- (b) The *System Operator* shall determine the *pre-dispatch schedule* for each scheduling interval using the *dispatch process* in which he takes into consideration the following inputs:
 - (1) *dispatch information* submitted for that scheduling interval;
 - (2) the *System Operator's forecast power system load* for that scheduling interval;
 - (3) *network constraints* determined under clause 6.4.5;
 - (4) *ancillary services constraints* determined under clause 6.4.6;
 - (5) system reserve *constraints* in accordance with clause 6.4.7;
 - (6) *dispatch inflexibilities* notified under clause 6.4.9; and
 - (7) any other matter that the *System Operator* reasonably considers to be relevant.

- (c) Any inputs made to the *dispatch process* by the *System Operator* for the purpose of achieving a physically realisable schedule or to satisfy *power system security* requirements shall be made prior to release of the *pre-dispatch schedule* and recorded by the *System Operator* in a manner suitable for audit.
- (d) Each *electric power producer* shall ensure that he is able to *dispatch* electricity as required under the *pre-dispatch schedule* and is responsible for changing inputs to the *dispatch process* if necessary.
- (e) The *pre-dispatch schedule* shall be re-calculated and the results re-published by the *System Operator* regularly in accordance with the timetable, or more often if a *change* in circumstances is deemed by the *System Operator* to be likely to have a significant effect on the *dispatch process*.
- (f) The *System Operator* shall fully document the operation of the *dispatch process*, including the principles adopted in making calculations required to be included and all such documentation shall be made available to *electric power producers* and any person who requests such documentation at a fee to be set by the *System Operator* to cover his costs of supplying such documentation.
- (g) The following *pre-dispatch* outputs relating specifically to a *generator* will be made available to that *electric power producer*:
 - (1) the scheduled times of *commitment* and *decommitment* of individual *generators*;
 - (2) scheduled half hourly loading for each *generator*;
 - (3) scheduled provision of *ancillary services*;
 - (4) scheduled *constraints* for the provision of *ancillary services*;
 - (5) scheduled *constraints* due to *network* limitations; and
 - (6) a specified *frequency response mode* to be selected for that *generator*.
- (h) Notwithstanding that the *System Operator* shall take the *pre-dispatch schedule* into account when preparing the *dispatch instruction* the *pre-dispatch schedule* produced by the *System Operator* in respect of a *day* shall be indicative only of the *dispatch instruction* relevant for that *day* and, accordingly, no *Code Participant* is entitled to claim any loss or damage from the *System Operator* as a result of any difference between the *pre-dispatch schedule* and the *dispatch instruction* for that *day*.

6.4.11 Dispatch instructions

- (a) After taking into consideration the *pre-dispatch schedule* prepared under clause 6.4.10 in respect of a *day* the *System Operator* may at any time give an instruction to an *electric power producer* in relation to any of his *generators* (a “*dispatch instruction*”), in accordance with clause 6.4.11(f), nominating:
 - (1) whether the *facilities* for *generation* remote control by the *System Operator*, if available, are required to be in service;
 - (2) the level or schedule of power to be supplied by the *generator* over the specified period;
 - (3) whether the transformer tap position associated with a *generator* is to be adjusted to a nominated tap consistent with the control range included in the registered data for that *generator* (provided under schedule 3.5);
 - (4) that:

- (i) the *generator's excitation control system voltage* set-point be set to give a nominated *voltage* consistent with the control range limits included in the registered data for that *generator* (provided in accordance with schedule 3.2 of the *Code*); or
 - (ii) the *generator* be operated to provide a nominated *reactive power* flow at the *generator* terminals for that *generator* consistent with the *generator* capability curve included in the registered data for that *generator* (provided in accordance with schedule 3.5 of the *Code*); and
- (5) a specified *frequency response mode* to be selected for that *generator*.
- (b) A *dispatch instruction* may also include any other instruction that the *System Operator* is entitled to give under an *ancillary services agreement* between the *System Operator* and the relevant *electric power producer* in relation to the provision of *ancillary services* or which the *System Operator* is otherwise entitled to give for the provision of *ancillary services*.
- (c) An *electric power producer* who has made a *generator* available under clause 6.4.2 shall ensure that appropriate personnel are available at all times to receive and immediately act upon *dispatch instructions* issued to the *electric power producer* by the *System Operator*.
- (d) A *dispatch instruction* applies from the time it is given (or any later time specified in the *dispatch instruction*) until the earlier of:
- (1) the cessation time specified in the *dispatch instruction* (if any); or
 - (2) the time when the next *dispatch instruction* applies.
- (e) An *electric power producer* shall comply with a *dispatch instruction* given to him by the *System Operator* unless to do so would, in the *electric power producer's* reasonable opinion, be a hazard to public safety or materially risk damaging equipment or the environment.
- (f) A *dispatch instruction* for a *generator* shall include the following:
- (1) specific reference to the *generator* or other *facility* to which the *dispatch instruction* applies;
 - (2) the desired outcome of the *dispatch instruction* such as *active power*, *reactive power*, transformer tap or other outcome;
 - (3) the ramp rate (if applicable) which is to be followed by the *generator* or a specific target time to reach the outcome specified in the *dispatch instruction*;
 - (4) the time the *dispatch instruction* is issued; and
 - (5) if the time at which the *dispatch instruction* is to take effect is different from the time the *dispatch instruction* is issued, the start time.

6.4.12 Failure to conform to dispatch instructions

- (a) If a *generator* fails to respond to a *dispatch instruction* within a tolerable time and accuracy (as determined in the *System Operator's* reasonable opinion), then:
- (1) the *generator* is to be declared and identified as non-conforming; and
 - (2) the relevant *electric power producer* may face financial penalties or other sanctions imposed under the PPA or his licence for breach of the *Code*.
- (b) If a *generator* is identified as non-conforming under clause 6.4.12(a):

- (1) the *System Operator* shall advise the *electric power producer* that the *generator* is identified as non-conforming, and request a reason for the non-compliance with the *dispatch instruction*, which reason is to be logged;
 - (2) if in the *System Operator's* opinion modification of *plant* parameters is necessary or desirable, the *System Operator* shall request the *electric power producer* to submit modified *plant* parameters to satisfy the *System Operator* that a realistic real time *dispatch* schedule can be carried out; and
 - (3) should an *electric power producer* fail to meet the requests set out in clauses 6.4.12(b)(1) and (2) or if the *System Operator* is not satisfied that the *generator* will respond to future *dispatch instructions* as required, the *System Operator* shall direct the *generator's* output to follow as far as is practicable, a specified output profile to be determined at his discretion by the *System Operator*.
- (c) Until an *electric power producer* satisfactorily responds to the requests under clauses 6.4.12(b)(1) and (2) and the *System Operator* is satisfied that the *generator* will respond to future *dispatch instructions* as required, the *generator* continues to be non-conforming.
- (d) If a *generator* continues to be non-conforming after a reasonable period of time, details of the non-conformance shall be recorded and the *electric power producer* and the *Commission* shall be notified.
- (e) The direction referred to in clause 6.4.12(b)(3) is to remain in place until the *electric power producer* satisfies the *System Operator* of rectification of the cause of the non-conformance.

6.4.13 Dispatch related limitations

An *electric power producer* shall not, unless in the *electric power producer's* reasonable opinion, public safety would otherwise be threatened or there would be a material risk of damaging equipment or the environment:

- (a) send out any *energy* from a *generator*, except:
- (1) in accordance with the *self-dispatch* procedures specified in clause 6.4.14 up to the *self-dispatch* level;
 - (2) in accordance with a *dispatch instruction*;
 - (3) as a consequence of operation of the *generator's* automatic *frequency response mode* to *power system* conditions;
 - (4) in response to remote control signals given by the *System Operator* or by his *agent* on his behalf; or
 - (5) in connection with a test conducted in accordance with the requirements under Chapters 4 and 5;
- (b) adjust the transformer tap position or *excitation control system voltage* set-point of a *generator* except:
- (1) in accordance with a *dispatch instruction*;
 - (2) in response to remote control signals given by the *System Operator* or by his *agent*;
 - (3) if, in the *electric power producer's* reasonable opinion, the adjustment is urgently required to prevent material damage to the *electric power producer's plant* or associated equipment, or in the interests of safety; or

- (4) in connection with a test conducted in accordance with the requirements under clause 3.7;
- (c) energise a *connection point* in relation to a *generator* without prior approval from the *System Operator*. This approval shall be obtained immediately prior to energisation;
- (d) synchronise a *generator* to, or de-synchronise a *generator* from, the *power system* without prior approval from the *System Operator* except de-synchronisation as a consequence of the operation of automatic protection equipment or where such action is urgently required to prevent material damage to *plant* or equipment or in the interests of safety;
- (e) change the *frequency response mode* of a *generator* without the prior approval of the *System Operator*; or
- (f) remove from service or interfere with the operation of any *power system* stabilising equipment installed on that *generator*.

6.4.14 Commitment

(a) Self commitment

- (1) In relation to any *generator*, the relevant *electric power producer* shall confirm with the *System Operator*, the expected synchronising time at least one hour before the expected actual synchronising time, and update this advice 5 minutes before synchronising unless otherwise agreed with the *System Operator*. The *System Operator* may require further notification immediately before synchronisation.
- (2) Where an *electric power producer* has nominated a *self-dispatch* level in accordance with clause 6.4.4(a) the relevant *electric power producer* shall advise the *System Operator* when the relevant *generator* reaches the *self-dispatch* level and shall not increase output above that level unless instructed otherwise by the *System Operator* to increase output.

(b) Direction by the *System Operator* to commit a *generator* for service

- (1) A *dispatch instruction* for a *generator* to be committed given by the *System Operator* shall be consistent with the start-up time specified in the latest *dispatch information* in relation to the *generator*.
- (2) When the *System Operator* issues a *dispatch instruction* to an *electric power producer* for *commitment*, the *System Operator* shall nominate the time at which the applicable *generator* is to be synchronised.
- (3) After a *dispatch instruction* for *commitment* of a *generator* has been issued, the relevant *electric power producer* shall promptly advise the *System Operator* of any inability to meet the nominated time to synchronise.

6.4.15 De-commitment

- (a) An *electric power producer* shall confirm with the *System Operator* the expected de-synchronising time at least one hour before the expected actual de-synchronising time, and update this advice 5 minutes before de-synchronising unless otherwise agreed with the *System Operator*. The *System Operator* may require further notification immediately before de-synchronisation.
- (b) Information to be confirmed with the *System Operator* to *de-commit* a *generator* shall include:

- (1) the time to commence decreasing the output of the *generator*;
- (2) the ramp rate to decrease the output of the *generator*;
- (3) the time to de-synchronise the *generator*; and
- (4) the output from which the *generator* is to be de-synchronised.

6.4.16 Generating plant changes

An *electric power producer* shall, without delay, notify the *System Operator* of any event which has changed or is likely to change the operational availability of any of his *generators*, whether the relevant *generator* is synchronised or not, as soon as the *electric power producer* becomes aware of the event.

6.5 ANCILLARY SERVICES

6.5.1 Introduction

- (a) Ancillary services are services that are essential to the management of *power system security* and ensure that electricity supplies are of acceptable quality and, without limitation, may include:
 - (1) the provision of sufficient regulating capability to meet fluctuations in *load* occurring within a scheduling interval;
 - (2) the provision of sufficient *contingency capacity reserve* to maintain *power system frequency* in accordance with Chapter 7 in the event of *network* or *generation* outages;
 - (3) the provision of *reactive support* to guard against *power system* failure through *voltage* collapse; and
 - (4) the provision of *black start capability* to allow restoration of *power system* operation after a complete failure of the *power system* or part of the *power system*.
- (b) The requirements for *ancillary services* as specified in Chapter 7 are to be met in the following ways:
 - (1) through minimum standards in the *Code* for technical performance that require some level of *ancillary service* to be provided. These are to be dealt with in *Code Participants' connection agreements*; or
 - (2) by the *System Operator* purchasing *ancillary services* as required under 6.5.3.

6.5.2 Ancillary services not purchased by the System Operator

- (a) The *System Operator* is not responsible for payment to a *Code Participant* for *ancillary services* which shall be provided by that *Code Participant* under a *connection agreement* as identified in schedules 3.1, 3.2 and 3.3.
- (b) A *network service provider* shall promptly advise the *System Operator* of all *ancillary services* to be provided by a *Code Participant* under such a *connection agreement*.
- (c) The *System Operator* may direct a *Code Participant* to provide *ancillary services* agreed to be provided under a *connection agreement* of a kind described in clause 6.4.2(a) and any *Code Participant* so directed shall use reasonable endeavours to comply with any such direction.

6.5.3 Ancillary services contracting by the System Operator

The *System Operator* shall use reasonable endeavours to enter into *ancillary services agreements* to provide sufficient *ancillary services* to meet the requirements of Chapter 7 taking into account those which are available for provision or provided under *connection agreements*.

6.5.4 Ancillary services agreements

- (a) The *System Operator* shall seek to establish contracts for the provision of *ancillary services*.
- (b) Unless otherwise agreed between the parties, payment by the *System Operator* under an *ancillary services agreement* may contain but is not limited to:
 - (1) components based on either or both of the contracted capabilities and a measure of the *ancillary service* actually provided;
 - (2) a component reflective of demonstrable opportunity cost (i.e. lost revenue or opportunity) incurred by the *Code Participant* in providing the *ancillary service*;
 - (3) a component to provide the *Code Participant* with a fair return in respect of any additional direct costs associated with providing the *ancillary service*.
- (c) The *System Operator* and a *public electricity supplier* may establish contracts from time to time for the provision of *ancillary services* by the *System Operator* to or on behalf of that *public electricity supplier* and the payments to be made by that *public electricity supplier* to the *System Operator* under any such contracts so established.

6.5.5 Provision of ancillary services

- (a) A *Code Participant* shall not unreasonably refuse to provide *ancillary services*.
- (b) When justifiable in terms of *power system security*, the *System Operator* may direct any *Code Participant* to provide an *ancillary service* where the *Code Participant's plant* is capable of doing so.
- (c) If:
 - (1) the *System Operator* directs a *Code Participant* to provide *ancillary services* and the *Code Participant* provides the *ancillary services*;
 - (2) there is no *ancillary services agreement* in place with that *Code Participant* in respect of the required *ancillary service*; and
 - (3) the availability of the relevant *plant* has not otherwise been acquired through a process conducted by the *System Operator* to provide *ancillary services*
 the *System Operator* shall offer compensation to that *Code Participant* in respect of the *ancillary services* provided, in accordance with clause 6.5.5(d).
- (d) The level of compensation paid to a *Code Participant* who has provided *ancillary services* under clause 6.5.5(c) shall be either:
 - (1) the demonstrable opportunity cost (e.g. lost net revenue or opportunity) plus variable *operating costs* incurred by the provider in providing the *ancillary service*, or
 - (2) the value of the *ancillary service* where that value can be ascertained, or
 - (3) a value recommended by the *System Operator*.

- (e) If compensation offered under clause 6.5.5(c) is not accepted by the *Code Participant* and the level of compensation cannot be agreed, the *Code Participant* may seek a determination of a reasonable level of compensation based on the matters described in clause 6.5.5(d)(1) and (2) in accordance with the dispute resolution procedures set out in clause 11.2.

6.5.6 Performance testing

Ancillary services agreements shall contain a provision pursuant to which the capability to provide *ancillary services* shall be demonstrated from time to time to the satisfaction of the *System Operator* according to standard test procedures.

CHAPTER 7 POWER SYSTEM SECURITY**TABLE OF CONTENTS**

| | Page |
|--|------|
| 7.1 INTRODUCTION | 202 |
| 7.2 DEFINITIONS AND PRINCIPLES | 202 |
| 7.2.1 Power system security and reliability standards | 202 |
| 7.2.2 Satisfactory operating state | 202 |
| 7.2.3 Credible and non-credible contingency events | 203 |
| 7.2.4 Secure operating state and power system security | 204 |
| 7.2.5 Technical envelope | 204 |
| 7.2.6 General principles for maintaining power system security | 204 |
| 7.2.7 Reliable operating state | 205 |
| 7.2.8 Time for undertaking action | 205 |
| 7.3 POWER SYSTEM SECURITY RESPONSIBILITIES AND OBLIGATIONS | 205 |
| 7.3.1 Responsibility of the System Operator for power system security | 205 |
| 7.3.2 The System Operator's obligations | 207 |
| 7.3.3 Sensitive loads and load shedding | 208 |
| 7.3.4 Network service providers | 209 |
| 7.3.5 Public electricity supplier obligations | 209 |
| 7.4 POWER SYSTEM FREQUENCY CONTROL | 209 |
| 7.4.1 Power system frequency control responsibilities | 209 |
| 7.4.2 Operational frequency control requirements | 209 |
| 7.4.3 Generator protection requirements | 210 |
| 7.5 CONTROL OF POWER SYSTEM VOLTAGE | 210 |
| 7.5.1 Power system voltage control | 210 |
| 7.5.2 Reactive power reserve requirements | 211 |
| 7.5.3 Audit and testing | 211 |
| 7.6 PROTECTION OF POWER SYSTEM EQUIPMENT | 211 |
| 7.6.1 Power system fault levels | 211 |
| 7.6.2 Power system protection co-ordination | 211 |
| 7.6.3 Audit and testing | 211 |
| 7.6.4 Short-term thermal ratings of power system | 212 |
| 7.6.5 Partial outage of power protection systems | 212 |
| 7.7 POWER SYSTEM STABILITY CO-ORDINATION | 212 |
| 7.7.1 Stability analysis co-ordination | 212 |

| | |
|---|-----|
| 7.7.2 Audit and testing | 213 |
| 7.8 POWER SYSTEM SECURITY OPERATIONS | 213 |
| 7.8.1 Code Participants' advice | 213 |
| 7.8.2 Network service provider's advice to the System Operator | 213 |
| 7.8.3 Protection or control system abnormality | 213 |
| 7.8.4 The System Operator's advice on power system emergency conditions | 213 |
| 7.8.5 Declaration of low reserve or lack of reserve conditions | 214 |
| 7.8.6 Managing low reserve or lack of reserve | 214 |
| 7.8.7 Cancellation of lack of reserve and low reserve declaration | 214 |
| 7.8.8 Managing a power system contingency event | 214 |
| 7.8.9 Managing electricity supply shortfall events | 215 |
| 7.8.10 Directions by the System Operator affecting power system security | 215 |
| 7.8.11 Disconnection of generators | 216 |
| 7.8.12 Emergency black start facilities | 216 |
| 7.8.13 Local black system procedures | 216 |
| 7.8.14 Testing of black start facilities and local black system procedures | 216 |
| 7.8.15 Black system start-up | 217 |
| 7.8.16 Review of operating incidents | 217 |
| 7.9 POWER SYSTEM OPERATING PROCEDURES | 218 |
| 7.9.1 Power system operating procedures | 218 |
| 7.9.2 Transmission network operations | 218 |
| 7.9.3 Operating interaction with distribution networks | 219 |
| 7.9.4 Switching of a distribution network service provider's HV networks | 219 |
| 7.9.5 Switching of reactive power facilities | 219 |
| 7.9.6 Automatic reclose | 219 |
| 7.9.7 Inspection of facilities by the System Operator | 219 |

| | |
|---|-----|
| 7.10 POWER SYSTEM SECURITY SUPPORT | 219 |
| 7.10.1 Remote control and monitoring devices | 219 |
| 7.10.2 Operational control and indication communication facilities | 220 |
| 7.10.3 Power system voice/data operational communication facilities | 220 |
| 7.10.4 Records of power system operational communication | 221 |
| 7.10.5 Agent communications | 221 |
| 7.11 NOMENCLATURE STANDARDS | 222 |
| 7.12 LIABILITY OF SYSTEM OPERATOR | 222 |

CHAPTER 7 POWER SYSTEM SECURITY

7.1 INTRODUCTION

- (a) This Chapter of the *Code*, which applies to, and defines obligations for, all *Code Participants*:
- (1) provides the framework for achieving and maintaining a secure *power system*;
 - (2) provides the conditions under which the *System Operator* can issue directions to *Code Participants* so as to maintain or re-establish a secure *power system*;
 - (3) has the following aims:
 - (i) to detail the principles and guidelines for achieving and maintaining *power system security*;
 - (ii) to establish the processes for the assessment of the adequacy of *power system reserves*; and
 - (iii) to establish processes and arrangements to enable the *System Operator* to plan and conduct operations within the *power system* to achieve and maintain *power system security*.
- (b) The *System Operator* has responsibility for *power system security*. This Chapter requires the *Minister* in consultation with the *Commission* to advise the *System Operator* of the requirements regarding *sensitive loads* and the policies to enable the *System Operator* to determine the priority of *load shedding*. The *System Operator* will make arrangements concerning the use of operational emergency powers over the *power system*.

7.2 DEFINITIONS AND PRINCIPLES

7.2.1 Power system security and reliability standards

The *power system security and reliability standards* are defined in the glossary to the *Code* and will be determined by the *System Planning and Reliability Council* described in clause 11.8 on the advice of the *System Operator*.

7.2.2 Satisfactory operating state

The *power system* is defined as being in a satisfactory operating state when:

- (a) the *frequency* at all energised *busbars* of the *power system* is within the normal operating *frequency* band except for brief excursions within the normal operating *frequency* excursion band as specified by the *power system security and reliability standards*;
- (b) the *voltage* magnitudes at all energised *busbars* at any switchyard or substation of the *power system* are within the relevant limits set by the *network service providers* in accordance with clause 7.5.1 and clause S3.1.4 of schedule 3.1;
- (c) the current flows on all *transmission lines* of the *power system* are within the ratings (accounting for time dependency in the case of emergency ratings) as defined by the relevant *network service providers* in accordance with schedule 3.1 in consultation with the *System Operator*;
- (d) all other *plant* forming part of or impacting on the *power system* is being operated within the relevant operating ratings (accounting for time dependency in the case of emergency ratings) as defined by *network service providers* in accordance with schedule 3.1;

- (e) the configuration of the *power system* is such that the severity of any potential fault is within the capability of circuit breakers to *disconnect* the faulted circuit or equipment; and
- (f) the conditions of the *power system* are stable in accordance with requirements designated in or under clause S3.1.8 of schedule 3.1.

7.2.3 Credible and non-credible contingency events

- (a) A “contingency event” means an event affecting the *power system* which the *System Operator* expects would be likely to involve the failure or removal from operational service of a *generator* or *transmission element*.
- (b) A “*credible contingency event*” means a contingency event the occurrence of which the *System Operator* considers to be reasonably possible in the surrounding circumstances including the *technical envelope*. Examples of *credible contingency events* typically include:
 - (1) the unexpected automatic or manual *disconnection* of, or the unplanned reduction in capacity of, one operating *generator*;
 - (2) the unexpected *disconnection* of one major item of *transmission plant* (e.g. *transmission line*, transformer or *reactive plant*) other than as a result of a three phase electrical fault anywhere on the *power system*.
- (c) A “*single credible contingency event*” means an individual *credible contingency event* for which a *Code Participant* adversely affected by the event would reasonably expect, under normal conditions, the design or operation of the relevant part of the meshed *power system* would adequately cater, so as to avoid significant disruption to *power system security*.
- (d) The “*critical single credible contingency event*” at any particular time is defined as a *single credible contingency event* considered by the *System Operator*, in the particular circumstances, to have the potential for the most significant impact on the *power system* at that time. This would generally be the instantaneous loss of the largest *generator* on the *power system*.
- (e) A “*non-credible contingency event*” is a contingency event other than a credible contingency event. It means a contingency event in relation to which, in the circumstances, the probability of occurrence is considered by the *System Operator* to be very low. Without limitation, examples of *non-credible contingency events* are likely to include:
 - (1) Three phase electrical faults on the *power system*; or
 - (2) Simultaneous disruptive events such as:
 - (i) multiple *generator* failures;
 - (ii) double circuit *transmission line* failure (such as may be caused by tower collapse); or
 - (iii) any abnormal conditions as described in clause 7.2.3(f).
- (f) Abnormal conditions are conditions posing added risks to the *power system* including, without limitation, severe weather conditions, lightning storms, and bush fires. During such abnormal conditions, the *System Operator* may, in his reasonable opinion, determine a *non-credible contingency event* (in particular, but without limitation, the tripping of some *substation* or switchyard *busbars* or both circuits of a double circuit *transmission line*) to be a credible contingency event.

The *System Operator* shall notify all *Code Participants* of such a re-classification as soon as practicable.

7.2.4 Secure operating state and power system security

- (a) The *power system* is defined to be in a secure operating state if, in the *System Operator's* reasonable opinion, taking into consideration the appropriate *power system security* principles described in clause 7.2.6:
- (1) the *power system* is in a satisfactory operating state; and
 - (2) the *power system* will return to a satisfactory operating state following the occurrence of a *single credible contingency event* in accordance with the standards approved by the *System Planning and Reliability Council* on the advice of the *System Operator* (“the *power system security and reliability standards*”).
- (b) Without limitation, in forming the opinions described in clause 7.2.4(a), the *System Operator* shall use the *technical envelope* as the basis of determining events considered to be *credible contingency events* at that time.

7.2.5 Technical envelope

- (a) The *technical envelope* means the technical boundary limits of the *power system* for achieving and maintaining the secure operating state of the *power system* for a given *demand* and *power system* scenario.
- (b) The *System Operator* shall determine and revise the *technical envelope* (as may be necessary from time to time) by taking into account the prevailing *power system* and *plant* conditions as described in clause 7.2.5(c).
- (c) The *technical envelope* determination shall take into account matters such as:
- (1) the *System Operator* forecast total *power system load*;
 - (2) the provision of the applicable *contingency capacity reserves*;
 - (3) operation within all *plant* capabilities and *constraints* on the *power system*;
 - (4) *contingency capacity reserves* available to handle a *single credible contingency event*;
 - (5) advised *generation* minimum *load constraints*;
 - (6) *constraints* on *transmission networks*, including short term limitations;
 - (7) *frequency* control requirements;
 - (8) *reactive power support* and *ancillary services* requirements; and
 - (9) the existence of proposals for any major equipment or *plant* testing, including the checking or possible *changes* in *transmission plant* availability.

7.2.6 General principles for maintaining power system security

The *power system security* principles are as follows:

- (a) To the extent practicable, the *power system* should be operated such that it is and will remain in a secure operating state.
- (b) Following a credible contingency event or a significant *change* in *power system* conditions, it is possible that the *power system* may no longer be in a condition which could be considered secure on the occurrence of a further contingency event. Following a contingency event (whether or not a credible contingency event) or a significant *change* in *power system* conditions, the *System Operator* should take all

reasonable actions to adjust, wherever possible, the operating conditions with a view to returning the *power system* to a secure operating state as soon as it is practical to do so and in any event within 30 minutes.

- (c) Adequate *load shedding facilities* initiated automatically by *frequency* conditions outside the normal operating *frequency* excursion band should be available and in service to restore the *power system* to a satisfactory operating state following significant multiple *contingency events*.
- (d) *Code Participants* should be required, either under their *connection agreements* or *ancillary services agreements* or as directed by the *System Operator*, to provide and maintain all required *facilities* consistent with *good electricity industry practice* and operate their equipment in a manner:
 - (1) to assist in preventing or controlling instability within the *power system*;
 - (2) to assist in the maintenance of, or restoration to a satisfactory operating state of the *power system*; and
 - (3) to prevent uncontrolled separation of the *power system*, *transmission* break-up, or *cascading outages*, following any *power system* incident.
- (e) Sufficient *black start facilities* should be available so as to allow the restoration of *power system security* and any necessary restarting of *generators* following a *black system* condition.

7.2.7 Reliable operating state

The *power system* is assessed to be in a reliable operating state when:

- (a) the *System Operator* has not *disconnected*, and does not expect to *disconnect*, any points of *load connection* under clause 7.8.9(a)(2);
- (b) no *load shedding* is occurring or expected to occur anywhere on the *power system* under clause 7.8.9(b); and
- (c) in the *System Operator*'s reasonable opinion the levels of short term and *medium term capacity reserves* available to the *power system* are at least equal to the required levels determined in accordance with *power system security and reliability standards*.

7.2.8 Time for undertaking action

The provisions of clause 1.7.1(l) do not apply to Chapter 7 and an event which is required under Chapter 7 to occur on or by a stipulated *day* shall occur on or by that *day* whether or not a *business day*.

7.3. POWER SYSTEM SECURITY RESPONSIBILITIES AND OBLIGATIONS

7.3.1 Responsibility of the System Operator for power system security

The *System Operator power system security responsibilities* are:

- (a) to maintain *power system security*;
- (b) to monitor the operating status of the *power system*;
- (c) to co-ordinate the *Code Participants* in undertaking certain of their activities and operations and monitoring activities of the *power system*;
- (d) to take reasonable steps to ensure that HV switching procedures and arrangements are utilised by *network service providers* to provide adequate protection of the *power system*;

- (e) to assess potential infringement of the *technical envelope* or *power system operating procedures* which could affect the security of the *power system*;
- (f) to operate the *power system* within the limits of the *technical envelope*;
- (g) to operate all *plant* and equipment under his control or co-ordination within the appropriate operational or emergency limits which are advised to the *System Operator* by the respective *network service providers* or *Code Participants*;
- (h) to assess the impacts of technical and any operational *constraints* on the operation of the *power system*;
- (i) to arrange the *dispatch* of *generators* (including *dispatch* by remote control actions or specific directions) in accordance with the *Code*, allowing for the dynamic nature of the *technical envelope*;
- (j) to determine any potential constraint on the *dispatch* of *generators* and the assessment of the effect of this constraint on the maintenance of *power system security*;
- (k) to assess the availability and adequacy, including the dynamic response, of *contingency capacity reserves* and *reactive power reserves* in accordance with the *power system security and reliability standards* and to take reasonable steps to ensure that appropriate levels of *contingency capacity reserves* and *reactive power reserves* are available:
 - (1) to ensure the *power system* is, and is maintained, in a satisfactory operating state; and
 - (2) to arrest the impacts of a range of significant multiple *contingency events* (affecting up to 60% of the total *power system load*) to allow a prompt restoration or recovery of *power system security*, taking into account *load shedding* capability provided under *connection agreements* or as otherwise;
- (l) to determine the required levels of *short term capacity reserves* and *medium term capacity reserves* in accordance with the *power system security and reliability standards*, and to assess the availability of the actual short term capacity reserve and actual *medium term capacity reserve* in accordance with the projected assessment of system adequacy (PASA), described in Chapter 6, which would be available to supplement utilised *contingency capacity reserves* and, if necessary, initiate action in relation to the availability of reserves in accordance with clause 7.8.5 and 7.8.6;
- (m) to make available to *Code Participants* as appropriate, information about the potential for, or the occurrence of, a situation which could significantly impact, or is significantly impacting on *power system security*, and advise of any *low reserve* condition for the relevant periods where the short term capacity reserve and/or *medium term capacity reserve* is assessed as being less than the *short term capacity reserve standard* or *medium term capacity reserve standard* respectively;
- (n) to refer to other *Code Participants*, as the *System Operator* deems appropriate, information of which the *System Operator* becomes aware in relation to significant risks to the *power system* where actions to achieve a resolution of those risks are outside the responsibility or control of the *System Operator*;
- (o) to utilise resources and services provided or procured as *ancillary services* or otherwise to maintain or restore the satisfactory operating state of the *power system*;

- (p) to procure as *ancillary services* the availability of *black start facilities* adequate to enable the *System Operator* to co-ordinate the response to a partial or total *black system* condition;
- (q) to interrupt, subject to clause 7.3.2(f), *Code Participant connections* as necessary during emergency situations to facilitate the re-establishment of the satisfactory operating state of the *power system*;
- (r) to direct (as necessary) any *Code Participant* to take action necessary to ensure, maintain or restore the *power system* to a satisfactory operating state;
- (s) to co-ordinate and direct any rotation of widespread interruption of *demand* in the event of a major *supply* shortfall or disruption;
- (t) to liaise with:
 - (1) *Code Participants* and the *Commission* should there be a need to manage an extensive disruption; and
 - (2) the *Minister* in relation to the use of emergency services powers;
- (u) to determine the extent to which the levels of *contingency capacity reserves* and *reactive power* reserves are or were appropriate through appropriate testing, auditing and simulation studies;
- (v) to investigate and review all major *power system* operational incidents and to initiate action plans to manage any abnormal situations or significant deficiencies which could reasonably threaten *power system security*. Such situations or deficiencies include without limitation:
 - (1) *power system frequencies* outside those specified in the definition of satisfactory operating state;
 - (2) *power system voltages* outside those specified in the definition of satisfactory operating state;
 - (3) actual or potential *power system* instability; and
 - (4) unplanned/unexpected operation of major *power system* equipment; and
- (w) to ensure that each *network service provider* satisfactorily interacts with the *System Operator* so that *power system security* is not jeopardised by operations on the *connected transmission networks* and *distribution networks*.

7.3.2 The System Operator's obligations

- (a) The *System Operator* shall use his reasonable endeavours, as permitted under the *Code*, including through the provision of appropriate information to *Code Participants* to the extent permitted by law and under the *Code*, to achieve the *System Operator power system security responsibilities* in accordance with *power system security* principles.
- (b) Where an obligation is imposed on the *System Operator* under this Chapter 7 to arrange or control any act, matter or thing or to ensure that any other person undertakes or refrains from any act, that obligation is limited to a requirement for the *System Operator* to use reasonable endeavours as permitted under the *Code*, including to give such directions as are within his powers, to comply with that obligation.
- (c) If the *System Operator* fails to arrange or control any act matter or thing or the acts of any other person notwithstanding the use of the *System Operator's* reasonable

endeavours, the *System Operator* will not be taken to have breached such obligation.

- (d) The *System Operator* shall make accessible to *Code Participants* such information as:
- (1) the *System Operator* considers appropriate;
 - (2) the *System Operator* is permitted to disclose in order to assist *Code Participants* to make appropriate decisions; and
 - (3) the *System Operator* is able to disclose to enable *Code Participants* to consider initiating procedures to manage the potential risk of any necessary action by the *System Operator* to restore or maintain *power system security*, provided that, in doing so, the *System Operator* shall use reasonable endeavours to ensure that such information is available to those *Code Participants* who request the information on equivalent bases.
- (e) Notwithstanding any other provision of the *Code*, the *System Operator* shall use his reasonable endeavours to ensure that the *power system* is operated in a manner that will maintain security of *supply* to any *sensitive loads* prescribed by the *Minister* under clause 7.3.3.
- (f) Notwithstanding any other provision of the *Code*, in the event that the *System Operator*, in his reasonable opinion for reasons of public safety or for *power system security*, needs to interrupt *supply* to any *sensitive loads*, the *System Operator* may effect that interruption and, if he has a reasonable opportunity to do so, the *System Operator* will notify the relevant *network service provider*.
- (g) The *System Operator* will liaise with the relevant *Code Participants* to assist in the management of any declared emergency *supply* situation necessary under clause 7.8.9 where there has been a major disruption to electricity *supply*.
- (h) After *disconnection*, notwithstanding any other provision of the *Code*, the relevant *network service provider* shall not take any steps to effect the reconnection of a *sensitive load* without the approval of the *System Operator* (which approval shall not be unreasonably withheld).

7.3.3 Sensitive loads and load shedding

- (a) The *Minister* shall, in consultation with the *Commission*, provide the *System Operator* with:
- (1) a schedule, updated as required by the *Minister*, of *sensitive loads* in priority order that pertain to the *System Operator*'s obligations under clause 7.3.2(e); and
 - (2) policies, updated as required by the *Minister*, to enable the *System Operator* to determine the priority of *load shedding* for all *load* which is not *sensitive load*.
- (b) For the purposes of undertaking any *load shedding* under clause 7.8, the *System Operator* shall develop (after liaising with relevant *network service providers* and the *System Planning and Reliability Council*) a priority *load shedding* schedule for all *load*, which is not *sensitive load*, in accordance with the policies of the *Minister* provided to the *System Operator* under clause 7.3.3(a)(2).

7.3.4 Network Service Providers

- (a) Each *network service provider* shall use reasonable endeavours to exercise his rights and obligations in relation to his *networks* so as to co-operate with and assist the *System Operator* in the proper discharge of the *System Operator power system security responsibilities*.
- (b) Each *network service provider* shall use reasonable endeavours, including without limitation, through the inclusion of appropriate provisions in *connection agreements*, to ensure that *interruptible loads* are provided as specified in clause 7.3.5 and clause S3.1.10 of schedule 3.1.
- (c) Each *network service provider* shall arrange controls, monitoring and secure communication systems which are appropriate in the circumstances to facilitate a manually initiated, rotational *load shedding* and restoration process which may be necessary if there is, in the *System Operator's* opinion, a prolonged major *supply* shortage or extreme *power system* disruption.
- (d) Each *network service provider* shall advise the *System Operator* of any *ancillary services* provided under any *connection agreement* to which he is a party.

7.3.5 Public electricity supplier obligations

- (a) All *public electricity suppliers* having expected peak demands at *connection points* in excess of 10 MW, shall provide automatic *interruptible load* of the type described in clause S3.1.10 of schedule 3.1. The level of this automatic *interruptible load* will be a minimum of 60% of their expected demand, or such other minimum *interruptible load* level as may be periodically determined by the *System Planning and Reliability Council*, to be progressively automatically disconnected following the occurrence of a *power system* under-frequency condition described in the *power system security and reliability standards*.
- (b) *Public electricity suppliers* shall provide their *interruptible load* in manageable blocks spread over a number of steps within under-frequency bands from 49.0 Hz down to 45.0 Hz as nominated by the *System Operator*. A *public electricity supplier* may also contract with the *System Operator* to provide *load* specified in this manner as an *ancillary service*.

7.4 POWER SYSTEM FREQUENCY CONTROL

7.4.1 Power system frequency control responsibilities

The *System Operator* shall use his reasonable endeavours to:

- (a) control the *power system frequency*; and
- (b) ensure that the *power system frequency operating standards* set out in the *power system security and reliability standards* are achieved.

7.4.2 Operational frequency control requirements

To assist in the effective control of *power system frequency* by the *System Operator* the following provisions apply:

- (a) The power to control and direct the output of *generators* is given to the *System Operator* pursuant to Chapter 6.
- (b) Each *electric power producer* shall ensure that all of his *generators* have responsive speed governor systems in accordance with the requirements of schedule 3.2, so as to automatically share in *changes* in *power system demand* or loss of *generation* as it occurs through response to the resulting excursion in *power system frequency*.

- (c) The *System Operator* shall use his reasonable endeavours to arrange to be available and specifically allocated to regulating duty such *generating plant* as the *System Operator* considers appropriate which can be automatically controlled or directed by the *System Operator* to ensure that all normal *load* variations do not result in *frequency* deviations outside the limitations specified in clause 7.2.2(a).
- (d) The *System Operator* shall use his reasonable endeavours to procure *ancillary services* and contractual arrangements associated with the availability, responsiveness and control of necessary *contingency capacity reserve* and the rapid unloading of *generation* as may be reasonably necessary to cater for the impact on the *power system frequency* of potential *power system* disruptions ranging from the *critical single credible contingency event* to the most serious multiple *contingency events*.
- (e) The *System Operator* shall use his reasonable endeavours to ensure that adequate *facilities* are available and are under the direction of the *System Operator* to allow the managed recovery of the satisfactory operating state of the *power system*.

7.4.3 Generator protection requirements

Electric power producers, as provided in schedule 3.2 and Chapter 3, are required to provide any necessary automatically initiated protective device or systems to protect their *plant* and associated *facilities* against abnormal *voltage* and extreme *frequency* excursions of the *power system*.

7.5 CONTROL OF POWER SYSTEM VOLTAGE

7.5.1 Power system voltage control

- (a) The *System Operator* shall determine the adequacy of the capacity to produce or absorb *reactive power* in the control of the *power system voltages*.
- (b) The *System Operator*, in consultation with *network service providers*, shall assess and determine the limits of the operation of the *power system* associated with the avoidance of *voltage* failure or collapse under *single credible contingency event* scenarios.
- (c) The limits of operation of the *power system* shall be translated by the *System Operator*, in consultation with *network service providers*, into key location operational *voltage* settings or limits, *transmission line* capacity limits, *reactive power* production (or absorption) capacity or other appropriate limits to enable their use by the *System Operator* in the maintenance of *power system security*.
- (d) The determination referred to in clause 7.5.1(b) shall include a review of the dynamic stability of the *voltage* of the *power system*.
- (e) The *System Operator* shall use his reasonable endeavours to maintain *voltage* conditions throughout the *power system* in accordance with the technical requirements specified in schedule 3.1.
- (f) The *System Operator* shall use his reasonable endeavours to arrange the provision of *reactive power facilities* and *power system voltage stabilising facilities* through:
 - (1) contractual arrangements for *ancillary services* with appropriate *Code Participants*;
 - (2) directions relating to *ancillary services* given to appropriate *Code Participants*;
 - (3) negotiation and agreement with appropriate *network service providers*; or
 - (4) obligations on the part of *Code Participants* under their *connection agreements*.

- (g) Without limitation, such *reactive power facilities* may include:
- (1) *synchronous generator voltage* controls (rotor current adjustment) usually associated with tap-changing *transformers*;
 - (2) synchronous condensers (compensators);
 - (3) static VAR compensators (SVC);
 - (4) series or shunt capacitors;
 - (5) *shunt reactors*.

7.5.2 Reactive power reserve requirements

- (a) The *System Operator* shall use his reasonable endeavours to ensure that sufficient *reactive power* reserve is available at all times to maintain or restore the *power system* to a satisfactory operating state after the most critical contingency event as determined by previous analysis or by periodic contingency analysis by the *System Operator*.
- (b) If *voltages* are outside acceptable limits, and the means of *voltage* control set out in this clause 7.5 are exhausted, the *System Operator* shall take all reasonable actions, including to direct *changes to demand* (through selective *load shedding* from the *power system*), additional *generation* operation or reduction in the *transmission line* flows but only to the extent necessary to restore the *voltages* to within the relevant limits. A *Code Participant* shall comply with any such direction.

7.5.3 Audit and testing

The *System Operator* shall arrange, co-ordinate and supervise the conduct of appropriate tests to assess the availability and adequacy of the provision of *reactive power* to control and maintain *power system voltages* under both satisfactory operating state and contingency event conditions.

7.6 PROTECTION OF POWER SYSTEM EQUIPMENT

7.6.1 Power system fault levels

- (a) The *System Operator*, in consultation with *network service providers*, shall determine the fault levels at all *busbars* of the *power system* as described in clause 7.6.1(b).
- (b) The *System Operator* shall ensure that there are processes which will allow the determination of fault levels for normal operation of the *power system* and in anticipation of all *credible contingency events* which the *System Operator* considers may affect the configuration of the *power system* so that the *System Operator* can identify any *busbar* which could potentially be exposed to a fault level which exceeds the fault current ratings of the circuit breakers associated with that *busbar*.

7.6.2 Power system protection co-ordination

The *System Operator* shall use his reasonable endeavours to co-ordinate, in consultation with the *network service providers*, the protection of *transmission system plant* and equipment that the *System Operator* reasonably considers could affect *power system security*.

7.6.3 Audit and testing

The *System Operator* shall use his reasonable endeavours to co-ordinate such inspections and tests as the *System Operator* thinks appropriate to ensure that the

protection of the *power system* is adequate to protect against damage to *power system plant* and equipment.

7.6.4 Short-term thermal ratings of power system

- (a) The *System Operator* may act so as to use, or require or recommend actions which use the full extent of the thermal ratings of *transmission elements* to maintain *power system security*, including the short-term ratings (being time dependent ratings), as defined by the *network service providers* from time to time.
- (b) The *System Operator* shall use his reasonable endeavours not to exceed the ratings defined by the *network service providers* and not to require or recommend action which causes those ratings to be exceeded, to the extent that the *System Operator* is or ought reasonably to be aware of such ratings.

7.6.5 Partial outage of power protection systems

- (a) Where there is an outage of one protection system of a *transmission line*, the *System Operator* shall determine, in consultation with the relevant *network service provider*, the most appropriate action. Depending on the circumstances the determination may be:
 - (1) to leave the *transmission element* in service for a limited duration;
 - (2) to take the *transmission element* out of service immediately;
 - (3) to install a temporary protection system;
 - (4) to accept a degraded performance from the protection system, with or without additional operational measures or temporary protection measures to minimise *power system* impact; or
 - (5) to operate the *transmission element* at a lower capacity.
- (b) If there is an outage of both protection systems on a *transmission line* and the *System Operator* determines this to be an unacceptable risk to *power system security*, the *System Operator* shall take the *transmission element* out of service as soon as possible and advise the appropriate *network service provider* immediately this action is undertaken.
- (c) The *network service provider* shall comply with a determination made by the *System Operator* under this clause 7.6 unless in the reasonable opinion of the *network service provider*, it would threaten the safety of any person or cause material damage.

7.7 POWER SYSTEM STABILITY CO-ORDINATION

7.7.1 Stability analysis co-ordination

- (a) The *System Operator* shall use his reasonable endeavours to ensure that all necessary calculations associated with the stable operation of the *power system* as described in clause S3.1.8 of schedule 3.1 and for the determination of settings of equipment used to maintain that stability are carried out and to co-ordinate these calculations and determinations. The *network service provider* shall submit to the *System Operator* for approval the settings of any *transmission plant* used to maintain the stable operation of the *power system*.
- (b) The *System Operator* shall determine whether *power system* devices which the *System Operator* reasonably considers to be necessary to assist the stable operation of the *power system* should be installed by relevant *Code Participants* and in

making his determination the *System Operator* shall take into account the cost to the relevant *Code Participant* of installing those *power system* devices.

- (c) If the *System Operator* determines under clause 7.7.1(b) that a *Code Participant* should install a *power system* device, the *System Operator* shall advise the *Code Participant* accordingly and the *Code Participant* shall comply with that determination within a time frame agreed by the *System Operator* and the relevant *Code Participant*.

7.7.2 Audit and testing

The *System Operator* shall arrange, co-ordinate and supervise the conduct of such inspections and tests as he deems appropriate to assess the availability and adequacy of the devices installed to maintain *power system* stability.

7.8 POWER SYSTEM SECURITY OPERATIONS

7.8.1 Code Participants' advice

A *Code Participant* shall promptly advise the *System Operator* at the time that the *Code Participant* becomes aware of any circumstance which could be expected to adversely affect the secure operation of the *power system* or any equipment owned or under the control of the *Code Participant* or a *network service provider*.

7.8.2 Network Service Provider's advice to the System Operator

Each *network service provider* shall use his reasonable endeavours to promptly advise the *System Operator* after he becomes aware of any circumstance with respect to the *power system* which could reasonably be expected to affect the security of *supply* to or from any *Code Participant*.

7.8.3 Protection or control system abnormality

- (a) If a *Code Participant* becomes aware that any relevant protection system or control system is *defective* or unavailable for service, that *Code Participant* shall advise the *System Operator*. If the *System Operator* considers it to be a threat to *power system security*, the *System Operator* may direct that the equipment protected or operated by the relevant protection system or control system be taken out of operation or operated as the *System Operator* directs.
- (b) A *Code Participant* shall comply with a direction given by the *System Operator* under clause 7.8.3(a).

7.8.4 The System Operator's advice on power system emergency conditions

- (a) The *System Operator* shall publish all relevant details promptly after the *System Operator* becomes aware of any circumstance with respect to the *power system* which, in the reasonable opinion of the *System Operator*, could be expected to materially adversely affect *supply* to or from *Code Participants*.
- (b) Without limitation, such circumstances may include:
- (1) electricity *supply* capacity shortfall, being a condition where there is insufficient *generation* or *supply* options available to securely *supply* the total *load* including the *load* in a particular *supply area*;
 - (2) unexpected disruption of *power system security*, which may occur when:
 - (i) an unanticipated major *power system* or *generation plant* contingency event occurs; or

- (ii) significant environmental or similar conditions, including weather, storms or fires, are likely to, or are affecting the *power system*; or
- (3) a *black system* condition.

7.8.5 Declaration of low reserve or lack of reserve conditions

The *System Operator* may declare the following conditions in relation to a period of time, either present or future:

- (a) *Low reserve* condition - when the *System Operator* considers that the *short term capacity reserves* or *medium term capacity reserves* for the period being assessed have fallen below those determined by the *System Operator* as being in accordance with the relevant *short term capacity reserve standards* or *medium term capacity reserve standards*;
- (b) *Lack of reserve* level 1 (LOR1) - when the *System Operator* considers that there is insufficient capacity reserves available to provide complete replacement of the *contingency capacity reserve* on the occurrence of a *critical single credible contingency event* for the period nominated;
- (c) *Lack of reserve* level 2 (LOR2) - when the *System Operator* considers that the occurrence of a *critical single credible contingency event* is likely to require involuntary *load shedding*;
- (d) *Lack of reserve* level 3 (LOR3) - when the *System Operator* considers that *public electricity supplier load* (other than *ancillary services* or contracted *interruptible loads*) would be, or is actually being interrupted automatically or manually in order to maintain or restore the security of the *power system*.

7.8.6 Managing low reserve or lack of reserve

- (a) The *System Operator* shall publish any declaration under clause 7.8.5.
- (b) The *System Operator* may, in accordance with any guidelines issued by the *System Planning and Reliability Council*, give reasonable directions to any *electric power producer* in relation to his *generators* to require the *electric power producer* to do any act or thing which the *System Operator* deems necessary to maintain or re-establish the *power system* in a reliable operating state.
- (c) An *electric power producer* shall use his reasonable endeavours to comply with any such directions given to him by the *System Operator*.

7.8.7 Cancellation of lack of reserve and low reserve declaration

The *System Operator* shall publish notice of:

- (a) a cancellation of a declaration of *low reserve* or *lack of reserve* conditions; or
- (b) a *change* of the condition declared.

7.8.8 Managing a power system contingency event

- (a) During the period when the *power system* is affected by a *contingency event* the *System Operator* shall carry out actions, in accordance with the guidelines set out in the *power system security and reliability standards* and his obligations concerning *sensitive loads* to:
 - (1) identify the impact of the *contingency event* on *power system security* in terms of the capability of *generators* or *transmission* or *distribution networks*;
 - (2) identify and implement the actions required to restore the *power system* to its satisfactory operating state.

- (b) When *contingency events* lead to potential or actual electricity *supply* shortfall events, the *System Operator* shall follow the procedures outlined in clauses 7.8.9 and 7.8.10.

7.8.9 Managing electricity supply shortfall events

- (a) If, at any time and for any reason, there are insufficient *supply* options or *generation* available to securely *supply* total *load* (“major *supply* shortfall”), then the *System Operator* may undertake all or any of the following:
- (1) attempt to increase the *supply* capability or *generation* such as requesting available but not committed *generators* to start-up, or recall of *transmission plant* outages;
 - (2) *disconnect* one or more points of *load connection* as the *System Operator* considers necessary;
 - (3) direct in accordance with clause 7.8.10 a *public electricity supplier* to take such steps as are reasonable to immediately reduce his *load*.
- (b) If there is a major *supply* shortfall, the *System Operator* shall implement any *load shedding* required in an equitable manner as specified in the *power system security and reliability standards* up to the *power transfer capability* of the *network*.
- (c) If there is a major *supply* shortfall, the *System Operator* shall, to the extent possible in accordance with his obligations regarding *sensitive loads*, rotate any *load shedding* requirements in accordance with policies and schedules developed in accordance with clause 7.3.3(a) and (b).
- (d) The *System Operator* shall liaise with the *Commission* and the *Minister* if the management of an extensive *supply* disruption requires the use of emergency services powers.

7.8.10 Directions by the System Operator affecting power system security

- (a) Subject to clause 7.3.2 (g) and (h), if the *System Operator* is satisfied that it is necessary to do so for reasons of public safety or the security of the electricity system, the *System Operator* may issue directions authorising a person to require a *Code Participant* to do or, subject to clause 7.8.10(c), authorising a person to do, any one or more of the following acts or things:
- (1) to switch off, or re-route, a *generator*;
 - (2) to call equipment into service;
 - (3) to take equipment out of service;
 - (4) to commence operation or maintain, increase or reduce active or *reactive power* output;
 - (5) to shut down or vary operation;
 - (6) to shed or restore *load*;
 - (7) to do any other act or thing necessary to be done for reasons of public safety or the security of the *power system*.
- (b) A person authorised by a direction from the *System Operator* under clause 7.8.10(a) shall not take any action referred to in that clause unless the person has requested the *Code Participant* to take that action and the *Code Participant* has failed to take the action within a reasonable period.

- (c) The *System Operator* shall use his reasonable endeavours to exercise his powers under clause 7.8.10(a) in a manner which is consistent with the *sensitive loads*.
- (d) The *Commission* shall undertake a review of and report on the *System Operator*'s use of the powers granted to the *System Operator* under clause 7.8.10(a) in each *financial year* as part of the *Commission*'s annual report prepared in accordance with clause 11.7.4. The review shall consider for each occasion when the powers granted to the *System Operator* under clause 7.8.10(a) were exercised:
 - (1) whether the exercise, and the manner of exercise, of the powers granted to the *System Operator* under clause 7.8.10(a) was appropriate in the circumstances and was consistent with the *Code* objectives; and
 - (2) such other matters as the *Commission* considers appropriate, and may make any recommendations in relation to the *System Operator*'s future exercise of the power as the *Commission* considers appropriate.

7.8.11 Disconnection of generators

- (a) Where, under the *Code*, the *System Operator* has the authority or responsibility to *disconnect* a *generator*, then he may do so (either directly or through any *agent*) as described in clause 3.9.
- (b) The relevant *electric power producer* shall provide all reasonable assistance to the *System Operator* for the purpose of such *disconnection*.

7.8.12 Emergency black start facilities

The *System Operator* shall use reasonable endeavours to ensure that sufficient *facilities* are available and operable to provide for:

- (a) the maintenance or restoration of *power system security* under emergency conditions;
- (b) the restoration of all or any part of the *power system* to its satisfactory operating state following a significant disruption of the *power system*, involving significant loss of *load* and *generation*, and possibly resulting in major areas having no *supply* or a restricted *supply*; and
- (c) the availability, at all times, of not less than two independent power sources able to provide the black start capabilities, ("*black start facilities*") determined in accordance with the procedures developed by the *System Operator* to ascertain the qualities of *ancillary services* which the *System Operator* shall purchase.

7.8.13 Local black system procedures

- (a) Each *electric power producer* shall develop draft local *black system* procedures for each of his power stations and shall submit those procedures for approval by the *System Operator*.
- (b) The *System Operator* may request amendments to draft local *black system* procedures or any proposed *changes* as the *System Operator* reasonably considers necessary by notice in writing to an *electric power producer*.
- (c) If the *System Operator* and an *electric power producer* are unable to agree on the amendments, the matter may be dealt with under the dispute resolution procedures in clause 11.2.

7.8.14 Testing of black start facilities and local black system procedures

- (a) Each *electric power producer* providing *black start facilities* shall arrange for the testing of:

- (1) his *black start facilities* which are the subject of an *ancillary services agreement*; and
 - (2) the approved local *black system* procedures,
to be carried out in accordance with the System Operator's reasonable requirements at intervals nominated by the System Operator, not exceeding 12 months to demonstrate that:
 - (3) each of the *black start facilities* is capable of start-up from a condition where it is *disconnected* from external power supplies; and
 - (4) the arranged *black start facilities* can actually start up the nominated *generators* without assistance from the *power system*.
- (b) Each *electric power producer* providing *black start facilities* shall ensure that the auxiliary *plant* associated with those *black start facilities* is fully tested at intervals not exceeding three months.

7.8.15 Black system start-up

- (a) The *System Operator* shall advise a *Code Participant* if, in the *System Operator's* reasonable opinion, there is a *black system* condition which is affecting, or which may affect, that *Code Participant*.
- (b) If an *electric power producer* is providing *black start facilities* under an *ancillary services agreement*, then the local *black system* procedures for that *electric power producer* shall be consistent with that *ancillary services agreement*.
- (c) The *System Operator* may by notice in writing to the relevant *electric power producer* require such amendments to the local *black system* procedures for an *electric power producer* which, in his reasonable opinion, are needed for consistency with:
 - (1) actual *power system* requirements; or
 - (2) if the *electric power producer* is providing *black start facilities* under an *ancillary services agreement*, the relevant *ancillary services agreement*.
- (d) If the *System Operator* advises an *electric power producer* of a *black system* condition, and/or if the terms of the relevant local *black system* procedures require the *electric power producer* to take action, then the *electric power producer* shall comply with the requirements of the local *black system* procedures.
- (e) If there is a *black system* condition, then a *public electricity supplier* shall comply with the *System Operator's* instructions with respect to the timing and magnitude of *load* restoration.

7.8.16 Review of operating incidents

- (a) The *System Operator* shall conduct reviews of significant operating incidents or deviations from normal operating conditions in order to assess the adequacy of the provision and response of *facilities* or services, and the appropriateness of actions taken to restore or maintain *power system security*.
- (b) For all cases where the *System Operator* has been responsible for the *disconnection* of a *Code Participant* under the circumstances described in clause 7.8.16(a), a report of the review carried out in accordance with this clause 7.8.16 shall be provided by the *System Operator* to the *Code Participant* and the *Commission* advising of the circumstances requiring that action. Where the report relates to operating incidents which were of significance to the operation of the *power system*,

the report of the review carried out in accordance with this clause 7.8.16 shall be made available to *Code Participants* and the public.

- (c) A *Code Participant* shall co-operate in any such review conducted by the *System Operator* (including making available relevant records and information).
- (d) A *Code Participant* shall provide to the *System Operator* such information relating to the performance of his equipment during and after particular incidents or operating condition deviations as the *System Operator* reasonably requires for the purposes of analysing or reporting on those incidents or operating condition deviations.
- (e) The *System Operator* shall provide to a *Code Participant* such information or reports relating to the performance of that *Code Participant's* equipment during *power system* incidents or operating condition deviations as that *Code Participant* reasonably requests and in relation to which the *System Operator* is required to conduct a review under this clause 7.8.16.

7.9. POWER SYSTEM OPERATING PROCEDURES

7.9.1 Power system operating procedures

- (a) The *power system operating procedures* are:
 - (1) any instructions which may be issued by the *System Operator* from time to time relating to the operation of the *power system*;
 - (2) any guidelines issued from time to time by the *System Operator* in relation to *power system security*;
 - (3) *power system operating procedures* covering the operational activities and associated responsibilities of the relevant *network service provider* and any *Code Participants connected* to the relevant *transmission network* and operational activities for operational elements of the *transmission network* which interface with *electric power producers* and other *Code Participants* including, but not limited to, those relating to *sensitive loads*; and
 - (4) the *power system operating procedures* developed by the *System Operator* under clause 7.9.1(b) and any other procedures, instructions or guidelines which the *System Operator* nominates to be and advises to *Code Participants* as being *power system operating procedures* from time to time.
- (b) The *System Operator* shall compile the *power system operating procedures* in conjunction with the relevant *network service providers*.

7.9.2 Transmission network operations

- (a) The *System Operator* shall conduct or direct operations on the *transmission network* in accordance with the appropriate *power system operating procedures*.
- (b) A *Code Participant* shall observe the requirements of the relevant *power system operating procedures*.
- (c) *Code Participants* shall operate their equipment interfacing with the *transmission network* in accordance with the requirements of Chapter 3 any applicable *connection agreement*, *ancillary services agreement* and the associated *power system operating procedures*.
- (d) *Code Participants* shall ensure that *transmission network* operations performed on their behalf are undertaken by *authorised persons* advised in writing to the *System Operator*.

- (e) The *System Operator* shall ensure the regular review and update of the *power system operating procedures*.

7.9.3 Operating interaction with distribution networks

- (a) The *System Operator*, the *transmission network service provider* and each *distribution network service provider* shall maintain effective communications concerning the conditions of his *distribution network* and the *transmission network* or other *distribution network* to which that *distribution network* is *connected* and to co-ordinate activities where operations are anticipated to affect other *transmission* or *distribution networks*.
- (b) The *System Operator* shall use his reasonable endeavours to give at least 3 *days*' notice to all affected *distribution network service providers* prior to switching of a *transmission network* which could reasonably be expected to affect security of supply to any *distribution network*.

7.9.4 Switching of a distribution network service provider's HV networks

- (a) A *distribution network service provider* shall use reasonable endeavours to give the *System Operator* at least three *days*' prior notice of plans to carry out switching related to the HV *network* which could reasonably be expected to materially affect power flows at points of *connection* to a *transmission network*. The *distribution network service provider* shall also notify the *System Operator* immediately prior to carrying out any such switching.
- (b) A *distribution network service provider* shall provide confirmation to the *System Operator* of any such switching immediately after it has occurred.

7.9.5 Switching of reactive power facilities

- (a) The *System Operator* may instruct a *distribution network service provider* to place *reactive facilities* belonging to or controlled by that *distribution network service provider* into or out of service for the purposes of maintaining *power system security* where prior arrangements concerning these matters have been made between the *System Operator* and a *distribution network service provider*.
- (b) Without limitation to his obligations under such prior arrangements, a *distribution network service provider* shall use reasonable endeavours to comply with such an instruction given by the *System Operator* or his authorised *agent*.

7.9.6 Automatic reclose

- (a) The *System Operator* may request a *network service provider* to disable or enable *automatic reclose equipment* in relation to a particular *transmission* or *distribution network* circuit or a feeder connecting his *distribution network* to a *transmission network* which has *automatic reclose equipment* installed on it.
- (b) Prior to disabling or enabling *automatic reclose equipment* in relation to a *transmission network* circuit the relevant *transmission network service provider* shall notify the *System Operator*.

7.9.7 Inspection of facilities by the System Operator

The *System Operator* may inspect a *facility* of a *Code Participant* as specified in clause 3.7.1.

7.10 POWER SYSTEM SECURITY SUPPORT

7.10.1 Remote control and monitoring devices

- (a) All remote control, operational *metering* and monitoring devices and local circuits as described in schedules 3.2 and 3.3, shall be installed and maintained by a *network service provider* in accordance with the standards and protocols determined and advised by the *System Operator* (for use in the *control centres*) for each:
- (1) *generator connected to the transmission or distribution network of that network service provider*;
 - (2) substation provided by or directly *connected to the network of that network service provider*; and
 - (3) *ancillary service provided by that network service provider*.
- (b) The provider of any *ancillary services* shall arrange the installation and maintenance of all remote control equipment and remote monitoring equipment in accordance with the standards and protocols determined by the *System Operator* for use in the *control centre*.
- (c) The controls and monitoring devices shall include the provision for indication of *active power* and *reactive power* output, and to signal the status and any associated alarm condition relevant to achieving adequate control of the *transmission network*, and the *generating plant* active and reactive output.

7.10.2 Operational control and indication communication facilities

Each *network service provider* shall provide and maintain the necessary primary and, where nominated by the *System Operator*, back-up communications *facilities* for control, operational *metering* and indication from the relevant local sites to the appropriate interfacing termination as nominated by the *System Operator*.

7.10.3 Power system voice/data operational communication facilities

- (a) *network service providers, electric power producers and public electricity suppliers* shall advise the *System Operator* of each nominated person for the purposes of giving or receiving *operational communications* in relation to each of their *facilities*. The persons so nominated shall be those responsible for undertaking the operation of the relevant equipment.
- (b) Contact personnel details of each nominated person as referred to in clause 7.10.3(a) which shall be forwarded to the *System Operator* include:
- (1) title of contact personnel;
 - (2) the telephone numbers of those personnel;
 - (3) the telephone numbers of other available communication systems in relation to the relevant *facility*;
 - (4) a facsimile number for the relevant *facility*;
 - (5) an electronic mail address for the relevant *facility*; and
 - (6) a system of two-way radio communication with those personnel.
- (c) Each *Code Participant* shall provide, for each nominated person, two independent telephone communication systems fully compatible with the equipment installed at the *control centre*.
- (d) Each *Code Participant* shall maintain both telephone communication systems in good repair and shall investigate faults within 4 hours, or as otherwise agreed with the *System Operator*, of a fault being identified and shall repair or procure the repair of faults promptly.

- (e) Each *Code Participant* shall establish and maintain a form of electronic mail *facility* as approved by the *System Operator* for communication purposes (such approval may not be unreasonably withheld).
- (f) The *System Operator* shall advise all *Code Participants* of nominated persons for the purposes of giving or receiving *operational communications*.
- (g) Contact personnel details to be provided by the *System Operator* include title, telephone numbers, a facsimile number and an electronic mail address for the contact person.

7.10.4 Records of power system operational communication

- (a) The *System Operator* and the *network service providers* shall record each telephone *operational communication* in the form of log book entries or by another auditable method which provides a permanent record as soon as practicable after making or receiving the *operational communication*.
- (b) Records of *operational communications* shall include the time and content of each communication and shall identify the parties to each communication.
- (c) Voice recordings of telephone *operational communications* may be undertaken by the *System Operator* and the *network service providers*. The *System Operator* and the *network service providers* shall ensure that when a telephone conversation is being recorded under this clause, the persons having the conversation receive an audible indication that the conversation is being recorded. Voice recordings may be used as an alternative to written logs.
- (d) The *System Operator* and the *network service providers* shall retain all *operational communications* records including voice recordings for a minimum of 7 years.
- (e) In the event of a dispute involving an *operational communication*, the records of that *operational communication* maintained by, or on behalf of the *System Operator* will constitute prima facie evidence of the contents of the *operational communication*.

7.10.5 Agent communications

- (a) A *Code Participant* may appoint an *agent* (called a “*Code Participant Agent*”) to coordinate operations of one or more of his *facilities* on his behalf, but only with the prior written consent of the *System Operator*.
- (b) A *Code Participant* who has appointed a *Code Participant Agent* may replace that *Code Participant Agent* but only with the prior written advice to the *System Operator*.
- (c) The *System Operator* may only withhold his consent to the appointment of a *Code Participant Agent* under clause 7.10.5(a), if he reasonably believes that the relevant person is not suitably qualified or experienced to operate the relevant *facility* at the interface with a *transmission network*.
- (d) For the purposes of the *Code*, acts or omissions of a *Code Participant Agent* are deemed to be acts or omissions of the relevant *Code Participant*.
- (e) The *System Operator* and his representatives (including authorised *agents*) may:
 - (1) rely upon any communications given by a *Code Participant Agent* as being given by the relevant *Code Participant*; and
 - (2) rely upon any communications given to a *Code Participant Agent* as having been given to the relevant *Code Participant*.

- (f) The *System Operator* is not required to consider whether any instruction has been given to a *Code Participant Agent* by the relevant *Code Participant* or the terms of those instructions.

7.11 NOMENCLATURE STANDARDS

- (a) A *network service provider* shall use the nomenclature standards for *transmission plant* and apparatus as agreed with the *System Operator* or failing agreement, as determined by the *System Operator*.
- (b) A *Code Participant* shall use reasonable endeavours to ensure that his representatives comply with the nomenclature standards in any *operational communications* with the *System Operator*.
- (c) A *Code Participant* shall ensure that name plates on his equipment relevant to operations at any point within the *power system* conform to the requirements set out in the nomenclature standards.
- (d) A *Code Participant* shall use reasonable endeavours to ensure that nameplates on his equipment relevant to operations within the *power system* are maintained to ensure easy and accurate identification of equipment.
- (e) A *Code Participant* shall ensure that technical drawings and documentation provided to the *System Operator* comply with the nomenclature standards.
- (f) The *System Operator* may, by notice in writing, request a *Code Participant* to change the existing numbering or nomenclature of *transmission plant* and apparatus of the *Code Participant* for purposes of uniformity, and the *Code Participant* shall comply with such a request provided that if the existing numbering or nomenclature conforms with the nomenclature standards, the *System Operator* shall pay all reasonable costs incurred in complying with the request.

7.12 LIABILITY OF SYSTEM OPERATOR

To the extent permitted by law and except as expressly provided for in the *Code*, the *System Operator* shall not be liable for any loss or damage suffered or incurred by a *Code Participant* as a consequence of any act or omission performed in good faith by the *System Operator*.

CHAPTER 8 DISTRIBUTION SYSTEM OPERATION

TABLE OF CONTENTS

| | Page |
|--|------|
| 8.1 PRELIMINARY | 225 |
| 8.1.1 Purposes of this Chapter 8 | 225 |
| 8.1.2 To whom and how this Chapter 8 applies | 225 |
| 8.1.3 Other sources of rights and obligations | 225 |
| 8.2 DISTRIBUTION SYSTEM REQUIREMENTS | 225 |
| 8.2.1 Electric Power Industry Safety Code | 225 |
| 8.2.2 Maintenance standards | 226 |
| 8.2.3 Assets register | 226 |
| 8.2.4 Public lighting | 226 |
| 8.3 CONSUMERS' ELECTRICAL INSTALLATIONS | 226 |
| 8.3.1 Electrical installation By-laws and Regulations | 226 |
| 8.3.2 Consumers' general obligations | 226 |
| 8.3.3 Power factor | 228 |
| 8.3.4 Supply frequency | 228 |
| 8.3.5 Voltage | 228 |
| 8.3.6 Compliance with Chapter 3 of the Code | 229 |
| 8.3.7 Interruptions of supply | 230 |
| 8.3.8 Electromagnetic interference | 231 |
| 8.4 CONNECTION OF EMBEDDED GENERATORS | 232 |
| 8.4.1 Capability | 232 |
| 8.4.2 Delivery performance requirements of embedded generators | 232 |
| 8.4.3 Fault levels | 232 |
| 8.4.4 Earthing | 232 |
| 8.4.5 Electromagnetic interference | 232 |
| 8.4.6 Co-ordination of embedded generators | 233 |
| 8.4.7 Compliance with legislation | 233 |
| 8.5 EMERGENCIES AND SAFETY | 233 |
| 8.5.1 Disaster Preparedness and Management Committee | 233 |
| 8.5.2 Safety and other manuals | 233 |
| 8.6.DISTRIBUTION POWERLINE VEGETATION MANAGEMENT | 234 |
| 8.6.1 INTRODUCTION | 234 |
| 8.6.1.1 Objectives | 234 |
| 8.6.1.2 Application of section | 234 |

| | |
|--|-----|
| 8.6.1.3 Purpose | 234 |
| 8.6.1.4 Review | 234 |
| 8.6.2 Principles of maintaining clearance between distribution powerlines and vegetation | 234 |
| 8.6.2.1 General | 234 |
| 8.6.2.2 Vegetation Management | 235 |
| 8.6.2.3 Suitable Vegetation Species | 236 |
| 8.6.2.4 Important Vegetation | 236 |
| 8.6.2.5 Important Locations | 237 |
| 8.6.2.6 Vegetation Management Plans and Practices | 237 |
| 8.6.2.7 Weed Management | 237 |
| 8.6.3 Distribution powerline clearance standards | 238 |
| 8.6.3.1 General | 238 |
| 8.6.3.2 Fire Hazard Categories | 238 |
| 8.6.3.3 Factors Affecting Dimensions of Distribution Powerline Clearance | 238 |
| 8.6.3.4 Clearance Space Dimensions | 239 |
| 8.6.4 RESPONSIBILITIES | 242 |
| 8.6.4.1 The distribution network service provider | 242 |
| 8.6.4.2 The Consumer | 242 |
| 8.6.5 ROLE OF THE DISTRIBUTION NETWORK SERVICE PROVIDER | 242 |
| 8.6.5.1 Maintenance of the Clearance Space | 242 |
| 8.6.5.2 Assistance to the Public with Vegetation Matters | 243 |
| 8.6.5.3 Notification, Consultation and Negotiation | 243 |
| 8.6.5.4 Emergency Clearing | 244 |
| 8.6.5.5 Disputes | 244 |
| 8.6.5.6 Training | 244 |
| 8.6.6 SAG AND SWAY IN DISTRIBUTION POWERLINES | 244 |
| 8.6.6.1 SAG | 244 |
| 8.6.6.2 SWAY | 245 |

8.1 PRELIMINARY

8.1.1 Purposes of this Chapter 8

The purposes of this Chapter 8 are to regulate in a safe, efficient and reliable manner:

- (a) the *supply* of electricity to or from *distribution network service providers' distribution systems*; and
- (b) the way in which *consumers'* electrical installations and *embedded generators* affect the *distribution system* to which they are *connected*.

8.1.2 To whom and how this Chapter 8 applies

- (a) Each *distribution network service provider* shall comply with this Chapter 8 under each of the *distribution licence* and the *supply licence* held by the *distribution network service provider*.
- (b) As a result of requirements imposed on:
 - (1) each *distribution network service provider*, under the *distribution licence* and the *supply licence* he holds; and
 - (2) each *public electricity supplier* who is not a *distribution network service provider*, under the *supply licence* he holds,
 each contract for the *supply* of electricity entered into on or after the commencement date between:
 - (1) a *distribution network service provider* and a *consumer*; or
 - (2) a *public electricity supplier* which is not a *distribution network service provider* and a *consumer*:
 shall require the relevant *consumer* to comply with those provisions of this Chapter 8 which are expressed to impose obligations on *consumers*.
- (c) Each *electric power producer* with an *embedded generator* shall comply with this Chapter 8 under the *generation licence* held by him.

8.1.3 Other sources of rights and obligations

This Chapter 8 does not set out comprehensively all rights and obligations of *distribution network service providers*, *consumers* and *electric power producer* with *embedded generators* in respect of matters relating to:

- (a) the *supply* of electricity to or from *distribution network service providers' distribution systems*; and
- (b) the way in which *consumers'* electrical installations and *embedded generators* affect the *distribution system* to which they are *connected*,

so reference should be made to other statutes, regulations, proclamations, ordinances and by-laws binding upon a *distribution network service provider*, a *consumer* or an *electric power producer* with *embedded generator*.

8.2 DISTRIBUTION SYSTEM REQUIREMENTS

8.2.1 Electric Power Industry Safety Code

- (a) A *distribution network service provider* shall, in respect of electrical infrastructure installed into his *distribution system* or any replacement or modification of existing electrical infrastructure on or after the commencement date, comply with the Electric Power Industry Safety Code.

- (b) If a provision of this Chapter 8 is inconsistent with a provision of the Electric Power Industry Safety Code the provision of the Electric Power Industry Safety Code is to prevail to the extent of the inconsistency.

8.2.2 Maintenance standards

A *distribution network service provider* shall in relation to the maintenance of his electrical infrastructure:

- (a) adopt quality management and assurance procedures which:
- (1) comply with the laws and other performance obligations which apply to the provision of *distribution services*, including those contained in this *Code*; and
 - (2) minimize the risks associated with the failure or reduced performance of *assets*; and
- (b) adopt *good electricity industry practice*.

8.2.3 Assets register

A *distribution network service provider* shall keep a register of all electrical infrastructure and other *assets* forming part of his *distribution system*, which shall include:

- (a) a physical description of each item of electrical infrastructure or other *asset*, including its location; and
- (b) the value of each item of electrical infrastructure and other *asset*, calculated in accordance with accounting standards under the Corporations Law and, if not inconsistent with those accounting standards, generally accepted principles and practices applied from time to time in Kenya in the electricity *supply* industry.

8.2.4 Public lighting

A *distribution network service provider* in liaison with the relevant local authority shall repair or replace an item of public lighting within 7 *business days* of being notified by any person that such repair or replacement is necessary.

8.3 CONSUMERS' ELECTRICAL INSTALLATIONS

8.3.1 Electrical installation By-laws and Regulations

A *distribution network service provider* shall, in respect of *connection* of the *consumers'* electrical installation to his *distribution system*, use reasonable endeavours to ensure that the *consumer* is notified of his obligation to comply with any relevant electrical installation by-laws and regulations.

8.3.2 Consumers' general obligations

- (a) A *distribution network service provider* shall ensure that the tariff applicable to a *consumer* or an *individual contract* between a *consumer* and a *distribution network service provider* provides that a *consumer* shall:
- (1) not allow a *supply* of electricity to his electrical installation to be used other than at his premises nor will the *consumer supply* electricity so supplied to any other person without the prior approval of the *distribution network service provider*;
 - (2) not take electricity supplied to another *consumer's* electrical installation by a *distribution network service provider* at his premises;
 - (3) not interfere or allow interference with any equipment of his *distribution network service provider* which is on his premises except as may be permitted by law;

- (4) at all times, make available to his *distribution network service provider's* officers or *agents*, together with their equipment, a safe, convenient and unhindered access to the equipment of the *distribution network service provider* on his premises for any purposes associated with the *supply, metering* or billing of electricity or the inspection and/or testing of his electrical installation, provided that official identification is produced by the officers or *agents* on request. The *consumer* shall provide protective equipment to officers or *agents* of the *distribution network service provider* if that is necessary to ensure safe access to his premises;
 - (5) provide and maintain on his premises any reasonable or agreed *facility* required by his *distribution network service provider* to protect any equipment of the *distribution network service provider*;
 - (6) at his own expense, maintain his electrical installation in a safe condition to the satisfaction of his *distribution network service provider*;
 - (7) ensure that his electrical installation and any equipment within it (including protective equipment) are adequate, and effectively co-ordinated at all times with the electrical characteristics of his *distribution network service provider's* *distribution system*;
 - (8) use the electricity supplied to his electrical installation in a manner which, in the opinion of his *distribution network service provider*, does not interfere with the *supply* of electricity to other *consumers'* electrical installations or cause damage or interference to any third party; and
 - (9) at his own expense, maintain safe clearances between vegetation on the his property and electrical infrastructure providing *supply* to the his electrical installation.
- (b) A *distribution network service provider* shall ensure that the tariff applicable to a *consumer* or an *individual contract* between a *consumer* and a *distribution network service provider* provides that a *consumer* who, in respect of an electrical installation, has a maximum *demand* over 100 kVA shall, if the *distribution network service provider* is unable to continue to satisfy that maximum *demand* without installing a new substation, provide to the *distribution network service provider* the land upon which a new substation can be installed by the *distribution network service provider* in order to allow the *distribution network service provider* to satisfy that maximum *demand*.

8.3.3 Power factor

- (a) A *distribution network service provider* shall ensure that the tariff applicable to a *consumer* or an *individual contract* between a *consumer* and a *distribution network service provider* provides that a *consumer* (unless otherwise agreed with the *distribution network service provider*) shall, at all times, keep the *power factor* of his electrical installation within the relevant range set out in the table appearing below.

Table 1

| Supply voltage (kV) | Power factor range for <i>consumer</i> maximum demand and <i>voltage</i> | | | | | |
|---------------------|--|-----------------|----------------------|-----------------|-----------------|-----------------|
| | Up to 100 kVA | | Over 100 kVA - 2 MVA | | Over 2 MVA | |
| | Minimum lagging | Minimum leading | Minimum lagging | Minimum leading | Minimum lagging | Minimum leading |
| < 6.6 | 0.75 | 0.8 | 0.8 | 0.8 | 0.85 | 0.85 |
| 6.6 11 | 0.8 | 0.8 | 0.85 | 0.85 | 0.9 | 0.9 |
| 33 | 0.85 | 0.85 | 0.9 | 0.9 | 0.95 | unity |

- (b) If the *power factor* of an electrical installation falls outside the relevant range set out in the table appearing in clause 8.3.3(a), the *distribution network service provider* shall, forward a notice to the *consumer* requiring him to restore the *power factor* of the electrical installation within the relevant range.

8.3.4 Supply frequency

- (a) The *System Operator* is responsible for the frequency of each *distribution network service providers' distribution system*, in accordance with Chapter 7 of the *Code*.
- (b) A *distribution network service provider* has no obligation in respect of the frequency of his *distribution system*.

8.3.5 Voltage

- (a) Subject to a *consumer* fulfilling his obligations under the *Code*, the tariff or an *individual contract* and to clause 8.3.5(b) the *distribution network service provider* shall maintain a *voltage* level at the *point of supply* to the *consumer's* electrical installation at one of the following standard nominal *voltages*:

- (1) 230 V;
- (2) 400 V;
- (3) 6.6 kV;
- (4) 11 kV;
- (8) 33 kV;
- (8) 66 kV; or
- (9) replacements of the above standard nominal *voltages* published by KEBS from time to time.

- (b) Variations of the magnitude set out in the table appearing below around the relevant standard nominal *voltage* listed in clause 8.3.5(a) are permissible, unless otherwise agreed with the *consumer*.

Table 2

| Voltage level (kV) | Voltage range for time periods | | | |
|--------------------|---|--------------------|---|---|
| | Steady state (average over 5 minute period) | Less than 1 minute | Less than 10 seconds (excluding transient fluctuations - see clause S3.3.7) | Impulse voltage |
| < 1.0 | ± 6 % | ± 10 % | Phase to earth + 150 % - 100 % Phase to phase + 120 % - 100 % | 10 kV peak |
| 1-6.6 11 | ± 6 % (± 10 % for long feeders) | ± 10 % | Phase to earth + 180 % - 100 % Phase to phase +120 % - 100 % | 60 kV peak 95 kV peak 150 kV peak |
| 33 40 | ± 10 % | ± 15 % | Phase to earth + 150 % - 100 % Phase to phase +120 % - 100 % | 200 kV peak 250 kV peak |

- (c) If the *distribution network service provider* fails to fulfil his obligations under clause 8.3.5(a) in respect of a *consumer's* electrical installation he shall, within 20 *business days* of that failure being established, notify the *consumer* of what steps are to be taken to remedy that failure.

8.3.6 Compliance with Chapter 3 of the Code

The *distribution network service provider* shall ensure that *consumers* comply with the requirements of Chapter 3 of the *Code* in relation to:

- (a) negative sequence *voltage*;
- (b) balancing of *load* currents;
- (c) *voltage* fluctuations;
- (d) harmonics and *voltage* notching; and
- (e) any other matters referred to in Chapter 3 of the *Code*. If the *distribution network service provider* establishes that a *consumer* is not complying with the above requirements and this adversely affects other *consumers* or causes damages to

property or malfunction in electrical appliances, the *distribution network service provider* shall notify the *consumer* that he shall meet the above requirements and the *consumer* shall comply with such a notice.

8.3.7 Interruptions of supply

(a) A *distribution network service provider* shall:

- (1) use reasonable endeavours to ensure that the total duration of planned and unplanned interruptions to the *supply* of electricity to a *consumer's* electrical installation due to interruptions on the *distribution system* does not exceed on average for each HV *distribution* feeder, the frequency and duration figures per annum as detailed in the following Table 3:

Table 3

| Supply area category | Average reliability | |
|---|---------------------------------------|--------------------------------|
| | Annual number of supply interruptions | Annual total interruption time |
| Central business district (Nairobi and Mombasa) | 1 | 30 mins |
| Urban/suburban (Greater Nairobi, Greater Mombasa, Nakuru, Kisumu, Kisii, Eldoret, Thika, Nyeri, Nanyuki, Embu, Meru, Machakos, Malindi, Voi, Naivasha, Kakamega, Kitale, Garissa) | 2 | 2 hours |
| Other areas | 6 | 8 hours |

- (2) on request, make available to a *consumer* the applicable reliability targets relating to that *consumer* and the actual performance of the HV *distribution* feeder supplying that *consumer*.
- (b) Despite clause 8.3.7(a) and subject to any regulations made under the *Act* and a requirement that the *distribution network service provider* shall use his reasonable endeavours to act in accordance with the needs of *consumers* who have notified their *public electricity supplier* that a person at their address is reliant upon life support equipment under any regulations made under the *Act* and/or are classified as *sensitive loads* under clause 7.3.3(a) of the *Code*, the *distribution network service provider* may interrupt the *supply* of electricity to a *consumer's* electrical installation at any time for reasons including:
- (1) planned maintenance or repair of the *distribution network service provider's* *distribution system*;
 - (2) unplanned maintenance or repair of the *distribution network service provider's* *distribution system* in circumstances where, in the opinion of the *distribution network service provider*, the *connection* of the *distribution network service provider's* *distribution system* to the *consumer's* electrical installation poses an immediate threat of injury or material damage to any person or to the *distribution network service provider's* *distribution system*;
 - (3) the need to shed *load* in respect of the *consumer's* electrical installation because the total *demand* for electricity in Kenya at the relevant time exceeds the total *supply* available; or
 - (4) the need to eliminate the risk of fire.

- (c) If, for any reason, there ceases to be a *supply* of electricity from the *distribution network service provider's distribution system* to a *consumer's* electrical installation which:
- (1) satisfies the *consumer's demand* in respect of that electrical installation; and
 - (2) is necessary to prevent injury or material damage to any person or property,
- then the *distribution network service provider* shall use reasonable endeavours to restore that *supply* of electricity.
- (d) The *distribution network service provider* shall give any *consumer* whose electrical installation will not receive a *supply* of electricity due to planned maintenance or repair of the *distribution network service provider's distribution system* notice of that interruption to *supply* in accordance with any regulations made under the *Act*.
- The notice shall set out the date, time and probable duration of the interruption and include a contact telephone number for the *distribution network service provider*.
- (e) The *distribution network service provider* shall maintain a telephone information service to keep *consumers* whose electrical installations are affected by an interruption to *supply* arising otherwise than due to planned maintenance or repairs of the *distribution network service provider's distribution system* informed of the likely duration of the interruption.

8.3.8 Electromagnetic interference

- (a) A *distribution network service provider* shall ensure that a *consumer* complies with the requirement that the electromagnetic interference caused by a *consumer's* electrical installation or any appliances *connected* to that electrical installation is less than the limits set out in KS 1505 (Parts 1 to 3) -“Limits of Electromagnetic Interference from Overhead A.C. Power Lines and High Voltage Equipment Installations”.
- (b) An *electric power producer* with an *embedded generator* shall ensure that electromagnetic interference caused by the *electric power producer's embedded generator* is less than the limits set out in KS 1505 (Parts 1 to 3) -“Limits of Electromagnetic Interference from Overhead A.C. Power Lines and High Voltage Equipment Installations”
- (c) A *distribution network service provider* shall ensure that electromagnetic interference caused by his *distribution system* is less than the limits set out in KS 1505 (Parts 1 to 3) -“Limits of Electromagnetic Interference from Overhead A.C. Power Lines and High Voltage Equipment Installations”
- (d) A *distribution network service provider* shall investigate the source of any electromagnetic interference in his *distribution area* above the limits set in KS 1505 (Parts 1 to 3) -“Limits of Electromagnetic Interference from Overhead A.C. Power Lines and High Voltage Equipment Installations”
- (e) If a *distribution network service provider* establishes that the source of electromagnetic interference above the relevant limits is in his *distribution system*, he shall reduce the level of electromagnetic interference below those limits.
- (f) If a *distribution network service provider* establishes that the source of electromagnetic interference above the relevant limits is in a *consumer's* electrical installation, and that electromagnetic interference adversely affects other *consumers* or causes damage to property or malfunction in electrical appliances, the *distribution network service provider* shall notify the *consumer* that he shall reduce

the level of electromagnetic interference below those limits and the *consumer* shall comply with the notice.

8.4 CONNECTION OF EMBEDDED GENERATORS

8.4.1 Capability

A *distribution network service provider* shall ensure that his *distribution system* is able to receive a *supply* of electricity from an *embedded generator connected* to his *distribution system* on the basis set out in the relevant contract with the *electric power producer* concerned.

8.4.2 Delivery performance requirements of embedded generators

Unless otherwise agreed with the *distribution network service provider*, an *electric power producer* shall comply with the relevant operational requirements set out in Chapter 7 of the *Code* and the relevant *connection* requirements set out in Chapter 3 of the *Code* with the exception of the fault level requirements set out in clause 8.4.3.

8.4.3 Fault levels

Unless otherwise agreed in writing between an *electric power producer* with an *embedded generator* and the *distribution network service provider*, an *electric power producer* with an *embedded generator* shall design and operate his *embedded generator* so that it does not cause fault levels in the *distribution network service provider's distribution system* to exceed the levels set out in the table appearing below.

Table 4

| Voltage level kV | System fault level MVA | Short circuit level kA |
|------------------|------------------------|------------------------|
| 40 | 1000 | 13.1 |
| 33 | 750 | 13.1 |
| 11 | 250 | 13.1 |
| 6.6 | 150 | 13.1 |
| 0.415 | 36 | 50.0 |

8.4.4 Earthing

- (a) Unless otherwise agreed with the *distribution network service provider*, an *electric power producer* shall ensure that any metalwork of electrical apparatus and equipment forming part of his *embedded generator* is solidly earthed in a manner which, in the opinion of the *distribution network service provider*, is satisfactory.
- (b) Unless otherwise agreed with the *distribution network service provider*, an *electric power producer* shall ensure that all neutral earthing *connections* of each machine are capable of being solidly earthed.

8.4.5 Electromagnetic interference

If, as a result of an investigation under clause 8.3.8(d), a *distribution network service provider* establishes that the source of electromagnetic interference above the limits set out in KS 1505 (Parts 1 to 3) -“Limits of Electromagnetic Interference from Overhead A.C. Power Lines and High Voltage Equipment Installations” is in an *electric power producer's embedded generator*, and that the electromagnetic interference adversely affects other *consumers* or causes damage to property or malfunction in electrical appliances, the *distribution network service provider* shall notify the *electric power*

producer that he shall reduce the level of electromagnetic interference below those limits and the *electric power producer* shall comply with the notice.

8.4.6 Co-ordination of embedded generators

Electric power producers shall ensure that any *embedded generator connected* to a *distribution network service provider's distribution system*, and any equipment within it (including protective equipment) is adequate and effectively co-ordinated at all times with the electrical characteristics of the *distribution network service provider's distribution system*.

8.4.7 Compliance with legislation

An *electric power producer* shall, in respect of his *embedded generator*, comply with the Electric Power Industry Safety Code.

8.5 EMERGENCIES AND SAFETY

8.5.1 Disaster Preparedness and Management Committee

The *Minister* may recommend the appointment of the chief executive officer or other *authorised person* of any *Code Participant* as a member of the Disaster Preparedness and Management Committee and the *Code Participant* shall ensure that the chief executive officer, or such other *authorised person*, participates to the fullest extent possible in the preparation and review of any disaster plans and in carrying out any other functions of the Disaster Preparedness and Management Committee.

8.5.2 Safety and other manuals

- (a) Each *distribution network service provider* shall observe *good electricity industry practice* for the planning, design, construction, maintenance and operation of each *distribution network service provider's distribution system* to ensure that the relevant standards for safety and reliability of the system are consistent with community, business and *consumer* needs.
- (b) Each *distribution network service provider* shall maintain manuals approved by the *Commission* documenting design, construction, operation and maintenance standards that comply with the *good electricity industry practice*.

A *distribution network service provider* shall ensure that the tariff applicable to a *consumer* or an *individual contract* between a *consumer* and a *distribution network service provider* provides that the *consumer* shall supply, if requested, to the *distribution network service provider* or the *public electricity supplier* as the case may be details of *loads connected* or planned to be *connected* to the *distribution network service provider's distribution system* which the *distribution network service provider* requires for the purpose of planning his *distribution system*, including:

- (a) the location of the *load* in the *distribution system*;
- (b) existing *loads*;
- (c) existing *load* profile;
- (d) *changes* in *load* scheduling;
- (e) planned outages;
- (f) forecasts of *load* growth;
- (g) anticipated new *loads*;
- (h) anticipated redundant *loads*; and
- (i) the nature of any disturbing *loads*.

8.6.DISTRIBUTION POWERLINE VEGETATION MANAGEMENT

8.6.1.Introduction

8.6.1.1 Objectives

This Section is advisory only and has the following objectives:

- to promote public safety in respect of fire hazards;
- to establish a standard of care which should be observed when managing vegetation near *distribution powerlines*;
- to reduce vegetation related interruptions to electricity *supply*;
- to encourage the *distribution network service provider* to consult with affected persons, seek advice on specifics from the relevant authorities and have regard to any guidelines provided by relevant authorities; to balance fire safety, reliability of the electricity system and community costs with *conservation*, amenity, utility and heritage values in the best interests of the people of Kenya; and to minimise the effect of the management of vegetation around *distribution powerlines* on the natural environment.

8.6.1.2 Application of section

This section applies to any *distribution powerline*.

8.6.1.3 Purpose

The purpose of this section is to assist electricity entities in the management and the pruning and clearing of vegetation in the vicinity of *distribution powerlines*. To that end, this section sets out:

- the minimum standards and practices for maintaining vegetation clear of *distribution powerlines*;
- who is responsible for maintaining the *clearance space*; and
- the role of the *distribution network service provider*.

8.6.1.4 Review

This Section is to be reviewed by the *Commission* eighteen months after its commencement.

The *Commission* will provide a report of that review and propose any *changes* that are considered necessary and appropriate.

8.6.2 Principles of maintaining clearance between distribution powerlines and vegetation

8.6.2.1 General

There are a number of methods of maintaining the *clearance space*. The most common method is pruning and clearing of vegetation. Other methods include:

- using construction methods such as underground *electric supply lines*;
- selecting *distribution powerline* routes which avoid vegetation;
- using engineering solutions, for example, taller poles for low growth vegetation areas;
- planting appropriate vegetation species which will not interfere with *distribution powerlines* even when fully grown;

- informing private landowners as to appropriate vegetation species to be planted under and around *distribution powerlines*; and
- using insulated cables such as *aerial bundled cable* to reduce the *clearance space* required (refer clause 8.6.3.3).

Factors determining the most appropriate method of maintaining the *clearance space* include:

- minimisation of the potential risk to the public;
- cost;
- community *conservation* and heritage values, utility, amenity and visual impact;
- negotiation and consultation with owners or occupiers; and
- the type of vegetation and its growth and regrowth characteristics.

The nature of the ground conditions, topography, the nature and density of vegetation and climate will cause the cost of each method and any recurrent savings from avoided clearing and pruning to vary significantly from place to place.

It is for the *distribution network service provider* to determine the most appropriate method of maintaining the *clearance space* (refer clause 8.6.5.1). This does not preclude affected persons approaching the *distribution network service provider* in order to discuss alternatives.

8.6.2.2 Vegetation Management

Where pruning or clearing of vegetation is necessary, the *distribution network service provider* should employ effective management procedures. Personnel should be trained and skilled in pruning practices to recognised industry standards.

Correct pruning practices can discourage regrowth towards the *distribution powerline* and reduce:

- the frequency of pruning;
- the likelihood of disease and decay; and
- the risk of vegetation becoming a hazard to the public and the *distribution powerline* while maintaining the integrity, amenity and utility of the vegetation.

The *distribution network service provider* should have regard to the principles of prevention of soil erosion, and the preservation of water quality, windbreaks and specific wildlife habitat.

To provide a consistent and measurable approach to pruning or clearing vegetation near *distribution powerlines* and to assist people to understand these concepts, the following practices and classifications apply:

(a) Clearance space

The *clearance space* varies with the type of *distribution powerline* installed and the risk of the ignition of fire at that location (refer clauses 8.6.3.2 and 8.6.3.3). The *clearance space* is designed to provide fire safety in low to moderate fire risk areas and high to very high fire risk areas and reliability and continuity of electricity *supply*. The dimensions of the *clearance space* have been determined following consideration of the effect of adverse environmental and weather conditions (refer clause 8.6.3.4).

(b) Regrowth Space

The regrowth space required varies with the species of vegetation, the quality of the pruning or clearing, the micro-environment and the pruning and clearing cycle. Determining the regrowth rate is a matter of considering the factors involved. It should be assessed with the support of expert knowledge in vegetation management and following consultation with affected persons.

(c) Hazard Space

The *distribution network service provider* should take appropriate action in relation to trees and limbs in the hazard space to ensure the safety and reliability of the *distribution powerline*. The hazard space will vary with the species of vegetation and the extent of exposure to adverse weather conditions. The hazard space should be determined with reference to these factors and assessed with the support of vegetation management and arboriculture expertise, following consultation with affected persons.

(d) Pruning and Clearing Cycle

The pruning and clearing cycle is based on practical factors which include cost, local growing conditions and the anticipated vigour of the regrowth of species involved, coupled with the use of the land, community values and the utility and amenity the vegetation provides to the area. The pruning and clearing cycle need not be the same for all areas, but will be determined according to conditions in a particular location.

8.6.2.3 Suitable Vegetation Species

In some situations, vegetation cannot be pruned to the requirements of the Chapter across successive pruning and clearing cycles without destroying the vegetation's character, amenity and utility value or encouraging vigorous regrowth. In the longer term this could cause the vegetation to become unstable, unhealthy and a hazard to the public and the *distribution powerline*. This vegetation should be removed where judged appropriate following assessment of the vegetation's *conservation* value and appropriate consultation (see clause 8.6.5.3).

As a general rule, species with a mature height greater than 3.5 metres should not be planted or nurtured under *distribution powerlines*.

Saplings whose mature height will infringe the *clearance space* are best removed at an early stage of their growth to minimise cost and disruption to the area in the future.

Planting of suitable species by owners and occupiers will remove the potential risk to *distribution powerlines* and the need for costly recurrent pruning or clearing as well as retaining the amenity and utility value of vegetation to the public and environment. On public land, planting of suitable endemic species is preferred.

8.6.2.4 Important Vegetation

Locations recognised by relevant authorities or bodies as containing 'important vegetation' require special attention. For the purposes of this Chapter 'important vegetation' includes:

- botanically, historically or culturally important vegetation;
- vegetation of outstanding aesthetic value;
- vegetation of ecological significance; and
- the habitat of threatened species.

Before commencement of pruning and clearing the *distribution network service provider* should identify where the maintenance of the *clearance space*, the regrowth space and the hazard space may be detrimental to important vegetation. The

distribution network service provider should seek advice from the relevant authorities, for example the Ministry of Natural Resources and Environment, as well as land care and community groups as advised by the relevant authorities, to identify ‘important vegetation’.

Alternative *distribution powerline* routes or construction methods may help to preserve ‘important vegetation’. The manner in which this may be done needs to be decided in consultation between the *distribution network service provider* and the person or body responsible for the vegetation. This should result in an agreement on the most practical management arrangements and conditions that may apply.

8.6.2.5 Important Locations

The *distribution network service provider* should consult with the relevant authorities on the management of ‘important locations’. For the purposes of this Chapter ‘important locations’ contain the following:

- sites of historically or culturally important remnants or artefacts;
- sites of historically or culturally important events;
- sites of outstanding aesthetic value or landscape or streetscape values; or
- sites of ecological significance.

Before commencement of pruning and clearing the *distribution network service provider* should identify where the maintenance of the *clearance space*, the regrowth space and the hazard space may be detrimental to an important location. The *distribution network service provider* should seek advice from the relevant authorities, for example the Ministry of Natural Resources and Environment, the National Environmental Management Authority, local authorities, as well as community groups to identify ‘important locations’.

Alternative *distribution powerline* routes, construction methods or pruning and clearing methods may help to preserve ‘important locations’. The manner in which this may be done needs to be decided in consultation between the *distribution network service provider* and the person or body responsible for the location. This should result in an agreement on the most practical management arrangements and conditions that may apply.

8.6.2.6 Vegetation Management Plans and Practices

In undertaking vegetation management around powerlines a *distribution network service provider* should take into account vegetation management plans of third parties and vegetation management practices and projects applying to the area(s) immediately surrounding the *distribution powerline*.

8.6.2.7 Weed Management

When proposed pruning or clearing will change from the established practice for a location, the *distribution network service provider* should make reasonable endeavours to negotiate with the owner of the land satisfactory arrangements for avoiding the transfer of noxious weeds and diseases.

8.6.3 Distribution powerline clearance standards

8.6.3.1 General

The principal determinants of the dimensions of the *clearance space* are protection of the public from fire start potential and ensuring continuity and reliability of *supply*. Accordingly, the *clearance space* will vary depending on the fire hazard category of the area in which the *distribution powerline* is situated and factors associated with the type of *distribution powerline* installed.

8.6.3.2 Fire Hazard Categories

The risk of fire starting and spreading varies throughout Kenya. To establish the *clearance space* required, Kenya has been divided into two categories in which different *clearance space* dimensions apply:

- low to moderate fire risk areas (predominantly urban); and
- high to very high fire risk areas (predominantly rural).

At the boundary of fire risk areas, the *clearance space* requirements of the high to very high fire risk area may be applied to the low to moderate fire risk area for a distance of 100 metres.

The *distribution network service provider* should seek advice from the fire control authority as to the fire hazard rating of the area within which the *distribution network service provider* proposes to undertake vegetation management activity.

8.6.3.3 Factors Affecting Dimensions of Distribution Powerline Clearance

The dimensions of the *clearance space* are also dependent on factors associated with the type of *distribution powerline* installed and include:

(a) *Distribution powerline voltage* -

the *voltage* level of the *distribution powerline* influences the potential for electric discharge. The higher the *voltage* the greater the potential and hence the need for a greater *clearance space*.

(b) *Distribution powerline type* –

Insulating *distribution powerline* conductors reduces the risk of electric discharge. Using *aerial bundled cable* or other insulated conductors reduces the necessary dimensions of the *clearance space*.

(c) Span length (distance between poles) -

As the span length increases, the added weight of the *distribution powerline* conductors causes an increase in *distribution powerline* sag. *Distribution powerline* conductors can sway with the wind, therefore all dimensions of the *clearance space* shall be greater as the span length increases.

(d) Conductor size -

The size of a *distribution powerline* conductor affects its weight and therefore the amount that the conductor will sag. *Distribution powerline* conductors can sway with the wind therefore dimensions of the *clearance space* needs to increase as the size of the conductor increases.

(e) Distance along the *distribution powerline* conductors from the pole -

Along the *distribution powerline* conductors the greatest sag occurs midway between the supporting poles (on level ground). Therefore the dimensions of the

clearance space should be greater in the centre region of the span than near the pole. For uneven ground the greater sag will not necessarily occur at the mid-point of the span. Maximum *clearance space* dimensions are to apply at the point of maximum sag.

(f) Temperature of the *distribution powerline* conductors -

Increases in the temperature of *distribution powerline* conductors, caused by weather and the amount of electricity being carried, increases the sag of the conductors. These factors are in a state of continual *change*, so an allowance is made in the dimensions of the *clearance space* for the temperature of *distribution powerline* conductors.

8.6.3.4 Clearance Space Dimensions

- (a) The dimensions of the *clearance space* in low to moderate fire risk areas and high to very high fire risk areas for HV and LV *distribution powerlines* constructed with *aerial bundled cable* and insulated service cable are those prescribed in Table 1. For low to moderate fire risk areas only, the *clearance space* for *aerial bundled cable* at the pole as specified in column 1 of Table 1 may be reduced where tree trunks and limbs near the *aerial bundled cable* present no risk of abrasion. For low to moderate fire risk areas only, the *clearance space* between *aerial bundled cable* and foliage may also be reduced to allow foliage, which has insufficient strength to abrade the cable for the duration of the pruning and clearing cycle to remain in contact with the *aerial bundled cable*.

Table 1

| Type of Powerline | <i>Clearance Spaces/Point of Maximum Sag</i> | | | |
|-----------------------------|--|-----------------------|-------------------------|--------------------------|
| | At Pole | Away from Pole | | |
| | Column 1 All Spans | Column 2 Span <40m | Column 3 Span 40-70m | Column 4 Span 70-100m |
| | In all directions | | | |
| <i>Aerial bundled cable</i> | 0.3m | 0.5m | 0.5m | 0.7m |
| Insulated service cable | 0.5m | 0.6m | 1.0m | - |

- (b) The dimensions of the *clearance space* for low to moderate fire risk areas, for *distribution powerlines* other than those constructed with *aerial bundled cable* and insulated service cable and for the operating *voltages* given are those prescribed in Table 2.

Table 2

| Type of Powerline and Conductor | Clearance Spaces/ Point of Maximum Sag | | | | | | | | |
|---------------------------------|--|-----------------------|-------------------------|--------------------------|--------|---------------------------|--------|------------------------|--|
| | At Pole | Away from Pole | | | | | | | |
| | Column 1 All spans | Column 2 Span <40m | Column 3 Span 40-70m | Column 4 Span 70-100m | | Column 5 Span 100-150m | | Column 6 Span >150m | |
| Point of Maximum Sag | Vert. Below & Horiz. ¹ | Vert. Below & Horiz. | Vert. Below & Horiz. | Vert. Below | Horiz. | Vert. Below | Horiz. | Vert. Below | Horiz. |
| Bare LV ² All | 1.0m | 1.0m | 1.5m | 1.5m | 2.5m | 1.5m | 3.5m | 2.0m | The greater of 1.25 x sag + 0.5m or 3.5m |
| Bare HV Small ³ | 1.5m | 1.5m | 2.0m | 2.0m | 1.5m | 1.5m | 2.0m | 2.5m | The greater of 1.25 x sag + 0.5m or 2.5m |
| Medium | 2.0m | 2.0m | 2.0m | 2.0m | 2.5m | 3.0m | 2.0m | 2.5m | |
| Large | 2.5m | 2.0m | 3.5m | 4.5m | 2.5m | 2.5m | 2.5m | 2.5m | |

1 Vert. means vertically and Horiz. means horizontally.

2 See definition of conductor size in Chapter 14 for explanation of ‘Small’, ‘Medium’ and ‘Large’.

- (c) The dimensions of the *clearance space* for high to very high fire risk areas, for *distribution powerlines* other than those constructed with *aerial bundled cable* and insulated service cable and for the operating *voltages* given are those prescribed in Table 3.

Table 3

| | | <i>Clearance spaces/Point of Maximum Sag</i> | | | | | | | | |
|---------------------------------|-----------------------------------|--|----------------------|--------|-----------------------|--------|------------------------|--------|---------------------|--|
| | | At Pole | Away from Pole | | | | | | | |
| Type of Powerline and Conductor | Column 1 All spans | Column 2 Span <40m | Column 3 Span 40-70m | | Column 4 Span 70-100m | | Column 5 Span 100-150m | | Column 6 Span >150m | |
| | Vert. Below & Horiz. ⁴ | Vert. Below & Horiz. | Vert. Below | Horiz. | Vert. Below | Horiz. | Vert. Below | Horiz. | Vert. Below | Horiz. |
| Bare LV 5 All Conductors | 1.0m | 1.5m | 1.5m | 2.0m | 1.5m | 2.5m | 1.5m | 3.5m | 2.0m | The greater of 1.25 x sag + 0.5m or 3.5m |
| Bare HV | 1.5m | 1.5m | 2.0m | 2.0m | 2.0m | 2.0m | 2.0m | 2.0m | 2.5m | The greater of 1.25 x sag + 0.5m or 2.5m |
| Small 6 | 1.5m | 1.5m | 2.0m | 2.0m | 2.0m | 2.0m | 2.0m | 2.0m | 2.5m | |
| Medium | 1.5m | 1.5m | 2.0m | 2.0m | 2.0m | 2.5m | 2.5m | 3.5m | 2.5m | |
| Large | 1.5m | 1.5m | 2.0m | 2.0m | 2.0m | 3.0m | 2.5m | 4.5m | 2.5m | |

4 Vert. means vertically and Horiz. means horizontally.

5 See definition of conductor size in Chapter 2 for explanation of ‘Small’, ‘Medium’ and ‘Large’.

Notes Relating to the Tables

1. All dimensions given in the Tables are from a *distribution powerline* conductor in still air and account for the sag and sway of the conductor. For slender vegetation species and other unique situations, additional allowances may be necessary.
2. In low to moderate fire risk areas allowing limbs and foliage to grow over the *distribution powerline* from adjacent vegetation is strongly discouraged. Healthy and stable limbs may remain as provided the tree does not readily provide access to the powerline and the *voltage* of the *distribution powerline* does not exceed 33,000 volts. In high to very high fire risk areas foliage overhang is not permitted.
3. For *aerial bundled cable* and insulated service cable the *clearance space* can generally be in the form of a circle in low to moderate fire risk areas and high to very high fire risk areas.

4. The classifications are subject, by agreement between both parties, to any clearance areas negotiated by the owner with the *distribution network service provider* prior to the introduction of this section.

8.6.4 Responsibilities

8.6.4.1 The Distribution Network Service Provider

The *distribution network service provider* is responsible for keeping vegetation clear of *distribution powerlines*:

- (a) in safety and operational areas;
- (b) on his wayleaves;
- (c) in places where vegetation growing on private land may grow into the service line crossing the land for the purpose of *supplying* electricity to the contiguous (adjoining) land; and
- (d) in accordance with the requirements of this section.

8.6.4.2 The Consumer

Clause 8.3.2 of this *Code* requires that a *distribution network service provider* shall ensure that the tariff applicable to a *consumer* or an *individual contract* between a *consumer* and a *distribution network service provider* provides that a *consumer* shall, at his own expense, maintain safe clearances between vegetation on the *consumer's* property and electrical infrastructure providing *supply* to the *consumer's* electrical installation.

8.6.5 Role of the distribution network service provider

8.6.5.1 Maintenance of the Clearance Space

A *distribution network service provider* should:

- (a) keep the relevant *clearance space* prescribed in clause 8.6.3.4 free of vegetation at all times;
- (b) decide which method to adopt to ensure that the *clearance space* remains free of vegetation taking account of the potential risk to the public, *conservation* and other values and avoided costs associated with the alternatives;
- (c) if the method adopted is pruning or clearing, determine the regrowth space, hazard space and the pruning and clearing cycle;

Notes

1. Options available and matters for consideration when evaluating alternative methods are discussed in clause 8.6.2.1.
 2. While the *distribution network service provider* should decide how to maintain the *clearance space* this does not preclude persons from negotiating conditions under which other solutions may be used.
 3. Factors influencing regrowth space, hazard space and the pruning and clearing cycle are discussed in clause 8.6.2.2.
- (d) ensure that the pruning or clearing is done responsibly; and
 - (e) give special attention to how the *clearance space* is maintained at important locations (see clause 8.6.2.5) and the sites of important vegetation (see clause 8.6.2.4).

8.6.5.2 Assistance to the Public with Vegetation Matters

A *distribution network service provider* should:

- (a) assist the public so that pruning or clearing activities near *distribution powerlines* can be undertaken safely, this may require a *distribution network service provider* to de-energise *distribution powerlines* or do preliminary pruning to enable the clearance of vegetation safely; and
- (b) assist the community, when requested, in:
 - (i) setting safe limits of approach to *distribution powerlines* for pruning or clearing activities;
 - (ii) de-energising *distribution powerlines* to provide safe access;
 - (iii) obtaining advice on vegetation species and their growth habits; and
 - (iv) finding information on suitable vegetation species for planting near *distribution powerlines*; and
- (c) inform affected persons on request of the *distribution network service provider's* processes for considering alternative arrangements to avoid or reduce the need for pruning or clearing and the conditions that will apply to such arrangements and provide a publicised contact point within the organisation on vegetation management issues.

8.6.5.3 Notification, Consultation and Negotiation

A *distribution network service provider* should:

- (a) notify the occupiers of land, giving reasonable notice, before starting programmed pruning or clearing which will not involve *changes* to established practice. Notices should be informative, explaining why compliance with this section is necessary and stating the proposed time of the pruning and clearing. Where no one is in actual occupation of the land, notices to owners may be published in locally distributed newspapers;
- (b) consult with the owner of land when the proposed pruning or clearing will change from the established practice for that location and notify the occupiers of the land where the owner and the occupiers are not the same person;
- (c) when the proposed pruning or clearing will change from the established practice for that location, provide to the owner or, if not practical, the occupiers, a simple written explanation of the proposed method and extent of pruning or clearing which may include details of:
 - (i) the use of chemicals;
 - (ii) disposal of debris resulting from pruning or clearing;
 - (iii) avoiding transfer of noxious weeds and diseases; or
 - (iv) implementing measures to prevent bushfires from starting.

Note

When using chemicals due care should be observed to preserve public safety and quality assurance schemes.

- (d) when the proposed pruning or clearing will change from the established practice for that location, make reasonable endeavours to negotiate with the owner satisfactory arrangements in relation to the matters covered in clause 8.6.5.3(c); and

- (e) when the proposed pruning or clearing will change from the established practice for that location, consult with the occupiers or, if not practical, the owner of land, to make satisfactory arrangements for access to the *distribution network service provider's assets*.

8.6.5.4 Emergency Clearing

In emergency situations, the *distribution network service provider* may remove vegetation which poses an immediate risk in accordance with powers under the *Act*.

Under emergency circumstances, pruning may be undertaken without consultation, but the *distribution network service provider* should notify the owner or occupiers as soon as practicable after the removal of the vegetation.

8.6.5.5 Disputes

Disputes with owners or occupiers may arise from decisions made by a *distribution network service provider* in carrying out vegetation management activities. The *distribution network service provider* should endeavour to resolve any dispute in accordance with the *distribution network service provider's* documented dispute resolution process.

A *distribution network service provider* should make his dispute resolution processes available to interested parties as a public document. If this process fails to resolve the dispute, the matter may be referred to the *Commission*.

Notwithstanding the nature of the dispute and the need to resolve the dispute in an amicable manner, the responsibility of the *distribution network service provider* to maintain the *clearance space* at all times cannot be compromised.

8.6.5.6 Training

A *distribution network service provider* should ensure that any of his employees undertaking vegetation management in the vicinity of his powerlines, and any contractors he engages to carry out vegetation management, are appropriately trained and competent for that task.

Such training should cover the following areas:

- plant and weed identification;
- management of vegetation waste;
- precautions to avoid spread of weeds and plant diseases; and
- safe working practices near powerlines.

A *distribution network service provider* should seek advice from the relevant authorities as to appropriate training for vegetation management.

8.6.6 Sag and sway in distribution powerlines

8.6.6.1 Sag

The sag of a *distribution powerline* conductor can vary greatly during the *day*.

The amount of sag in any span is dependent on the:

- span length;
- *distribution powerline* conductor material;
- *distribution powerline* conductor tension;
- *distribution powerline* conductor size; and

- temperature.

The temperature of a *distribution powerline* conductor can vary dramatically in a space of half an hour resulting in a large increase of sag. This *change* in temperature can be caused by the ambient air temperature, solar radiation heating the conductor, or the electrical *load* on the *distribution powerline* conductor. The variation of the *distribution powerline* conductor's temperature is not normally detectable by a person observing the conductor and can result in unsafe *distribution powerline* clearances.

Under normal operating conditions, variations in the sag of a *distribution powerline* conductor in a span of less than 50 metres can be as great as 1 metre. In longer spans the variation of sag can be as great as 2 metres and in very long spans the actual sag may be more than 10 metres.

8.6.6.2 Sway

All *distribution powerline* conductors sway. In other words, *distribution powerline* conductors swing from side to side. The sway is often caused by wind passing over the *distribution powerline* conductor or by objects accidentally bumping the conductor or conductor supports. *Distribution powerline* conductors can sway greatly in light winds, which can set up resonant vibrations in the *distribution powerline*.

The possible amount of sway in any span is also dependent on the sag in that span of the *distribution powerline* at the time.

CHAPTER 9 GENERATION CAPACITY PLANNING AND PROCUREMENT

TABLE OF CONTENTS

| | Page |
|---|------|
| 9.1 GENERAL | 247 |
| 9.1.1 Key principles and objectives of generation capacity planning and procurement | 247 |
| 9.1.2 Power Purchase Agreements | 248 |
| 9.1.3 Key Provisions of a PPA | 249 |
| 9.2 GENERATION CAPACITY PROCUREMENT PROCESS | 250 |
| 9.2.1. Key issues in the design of the procurement process | 250 |
| 9.2.2 Project specification | 251 |
| 9.2.3 Post-Bid negotiations | 252 |
| 9.3. MARKET RULES | 252 |
| 9.3.1 Core rules | 252 |
| 9.3.1 Rules for the short term | 252 |
| SCHEDULES TO CHAPTER 9 | 254 |

CHAPTER 9 GENERATION CAPACITY PLANNING AND PROCUREMENT

9.1 GENERAL

- (a) The objectives of this Chapter 9 are to:
 - (1) set out the broad features of an approach to the regulation of *generation* capacity planning and procurement which should minimise the costs of future projects.
 - (2) create a regulatory *framework* that provides for open, transparent and competitive procurement of additional *generation* capacity and to ensure compliance with that framework.
- (b) This Chapter 9 is to be read subject to and in accordance with the *Act* and any subsidiary legislation made thereunder.
- (c) Section 121 (1) (f) of the *Act* empowers the *Commission* to approve electric power purchase contracts between and among *electric power producers*, *public electricity suppliers* and large retail *consumers*.
- (d) This Chapter 9 discusses the form of the Power Purchase Contracts, and the appropriate form of regulation to be exercised by the *Commission*.

9.1.1 Key principles and objectives of generation capacity planning and procurement

- (a) The *Commission* recognises that building a *generating plant* involves making a large up-front investment, the costs of which become sunk once the *plant* has been built, hence the need by potential investors for assurances in advance that they will be able to make a return on their investment once the *plant* has been built.
- (b) In a country in which the wholesale power market is untested, an investor would require a long-term contract that guarantees recovery of his sunk costs and insulates him from wholesale power market risks. The contract type that will be used to achieve this aim is the *Power Purchase Agreement*, or PPA.
- (c) The off-taker of a contract agreed with a developer will need to pass through the cost implications of the contract to its *consumers* for the duration of the contract in order for him to meet its contractual obligations.
- (d) Where the off-taker's *consumers* are *captive* such cost pass-through must be sanctioned by the *Commission*. Since this has a significant effect on end-user tariffs, it is the *Commission's* responsibility to ensure that:
 - (1) the contract is genuinely required to meet expected demand;
 - (2) the prices contained in the contract are fully justified; and
 - (3) the process for agreeing the contract is transparent and seen to be transparent.
- (e) The *Commission* will need to assure itself that the project represents good value for money, as will the lenders to a project, if a significant proportion of the financing is debt-based.

9.1.2 Power Purchase Agreements

- (a) Under a PPA, the return of the developers investment is guaranteed through capacity payments (provided the *plant* meets required availability targets), whilst the variable costs of *generation* are covered under separate *energy* payments. There are two types of PPA: firm and non-firm respectively.
- (b) Prices in PPAs are complex, typically consisting of:
 - (1) a capacity charge which incentivises *plant* availability and recovers the developers capital costs and fixed O&M plus profit;
 - (2) an *energy* charge which pays for *energy* supplied and recovers *operating costs*, mainly fuel; and
 - (3) payments for ancillary services e.g. *voltage* support, may be separately charged.
- (c) Under a non-firm PPA the off-taker takes most of the market risk, whilst the developers carry the construction and operating risks. *Plant* availability is incentivised and failure to meet availability targets penalised according to capacity payments determined ex ante in the contract. The *plant* is penalised for failing to meet prescribed availability targets, the penalties of which are specified in the contract.
- (d) Under a firm PPA the off-taker shares some of the market risk with the developer. *Plant* availability is incentivised through prices in the imbalance market according to capacity payments determined ex ante in the contract.
- (e) The PPA is the cornerstone of the "security package" to raise & finance for the project. For example, IPP projects are often over 75% debt financed; hence the requirements of the Lenders are often of prime importance in determining whether a deal will go ahead or not.
- (f) The *Commission* recognises that in developing markets such as Kenya, lenders including local commercial banks and International Financial Institutions are likely to require "tried and tested" methods of remuneration to be in place, such as PPAs, before a deal can be closed.
- (g) The PPAs will be of sufficient duration to allow for debt repayment; which in many cases is at least 15 years.
- (h) The role of the PPA and that of the other key contractual relationships that often need to be in place before a power development deal can be closed are depicted in the figure herebelow.

Contractual Structure for an Independent Power Project

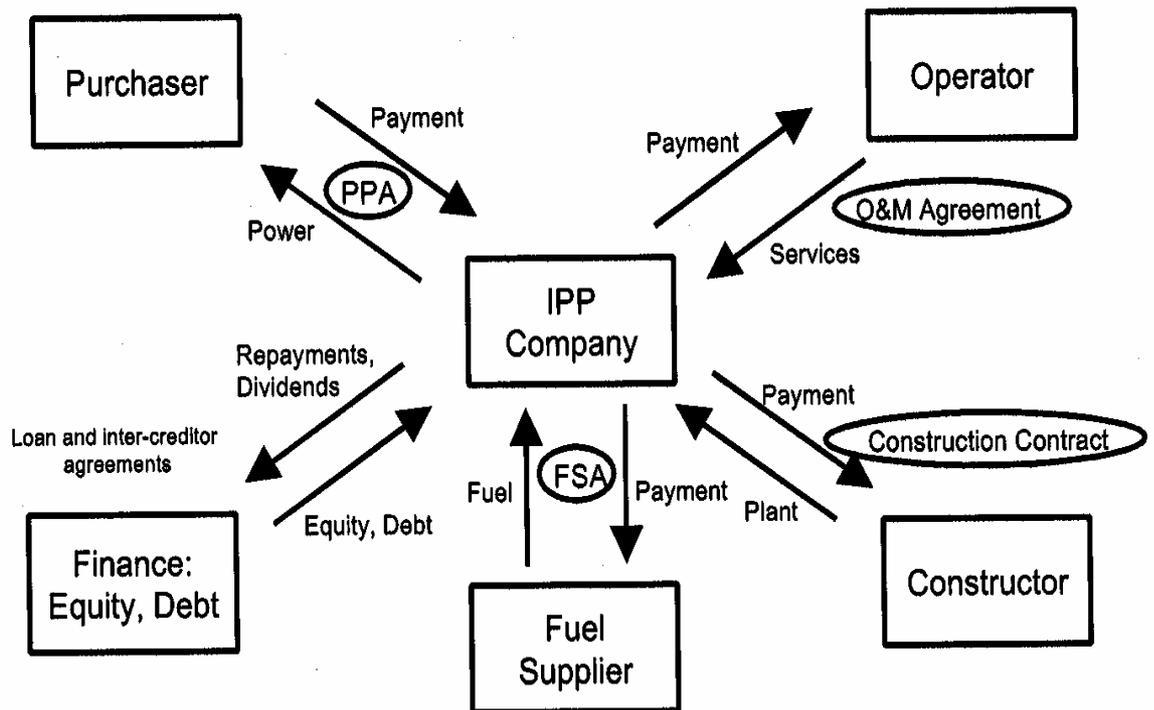

9.1.3 Key Provisions of a PPA

- (a) The key provisions of the PPA will be prescribed by the *Commission* and will include (without limitation) the following:
- (1) Definitions
 - (2) Commencement and Duration
 - (3) Scope of the Agreement
 - (4) Technical description
 - (5) Availability payments
 - (6) *Energy* payments
 - (7) Other Services
 - (8) *Metering*, payment and billing
 - (9) Records and confidentiality
 - (10) Force Majeure
 - (11) Liability and Insurance
 - (12) Default, termination, disputes
 - (13) Jurisdiction, changes of law, taxes and statutory levies.
- (b) Regulatory involvement shall take place in advance of contract signature, during the contracting stage. Regulation will therefore be of procedures, on an ex ante basis, rather than of prices, ex post.
- (c) In order to safeguard the interests of *consumers* and to protect the PPA from future re-negotiation or cost disallowal, the *Commission* will be involved in a regulatory

capacity in the procedure for agreeing new power contracts. This regulatory scrutiny shall also apply, as discussed in Schedule S9.2, to the planning procedure by which the need for new capacity is demonstrated by the off-taker.

- (d) Once the PPA is signed by the parties and approved by the *Commission* it shall be binding on the parties.

9.2 GENERATION CAPACITY PROCUREMENT PROCESS

9.2.1. Key issues in the design of the procurement process

- (a) *Generation* projects shall be selected on a competitive basis through a structured competitive procurement process unless evidence is given that no competitive tender is feasible. However, wherever there is a departure from the competitive procurement process, it must be fully justified.
- (b) The advantages of this approach include:
- (1) Encouraging suppliers to offer the best combination of price and non-price attributes while still making a profit. In contrast, negotiation with a preferred bidder does not subject that bidder to any competitive pressures;
 - (2) Creating a transparent process which is easier to regulate; and
 - (3) whilst it involves initial preparation costs, the process of agreeing the contract once the winning bid is selected is simpler and quicker.
 - (4) Ease of ascertaining the cost-effectiveness of a project selected through a competitive process: this is easier than if it was selected through, say one-to-one negotiation.
- (c) Competition gives instant benchmarks against which to judge the reasonableness of costs contained in the PPA; provided the correct procedures have been followed.
- (d) In so far as is practicably possible, *generation* capacity procurement procedures shall be based on objective selection criteria, since they allow full advantage to be taken of the competitive procurement process. Objective selection criteria:
- (1) maximise competitive pressures on bidders, encouraging them to reduce their prices;
 - (2) maximise the transparency of the bidding process, thereby reducing the risk to which bidders are exposed - both the risk that they will be unfairly discriminated against and the risk that, if selected, the *Commission* will not approve the costs of the contract for pass through to end users;
 - (3) facilitate regulation and reduce transactions costs - including notably the costs of negotiating prices and other key project parameters.
- (e) Risks to which the use of entirely objective selection criteria are prone to include the fact that the use of such criteria:
- (1) may result in the selection of a manifestly unqualified bidder. This risk shall be mitigated through the use of appropriate pre-qualification criteria, as discussed in Schedule 2 to this Chapter 9.
 - (2) will mean that relevant qualitative differences between proposals cannot be taken into account for bid selection purposes. This shall be mitigated by adopting appropriate project specifications.
- (f) Criteria that may be employed in *generation* procurement tendering procedures include:

- (1) Selection based on price alone. PPAs contain both capacity and *energy* prices, so the selection criterion may be based on one price alone, typically the capacity payment, or on a weighted average of these prices, producing a levelised per kWh price.
 - (2) Selection based on price plus other quantified criteria, such as contract length, target availability, etc.
 - (3) Selection based on price plus un-quantified criteria. "Pseudo" quantified criteria, i.e. allocating points for the quality of a given aspect of the bid; shall be treated on the same basis as un-quantified criteria in this respect.
 - (4) Selection based primarily on subjective criteria.
- (g) If project selection is made on the basis of price alone, a variety of options are possible; whether one of these prices or a combination of them is used as the selection criterion, the general principle that shall obtain is that prices and other relevant parameters (e.g. availability targets) that are not used as selection criteria shall be capped or fixed in model PPA, and therefore shall be common to all bidders.
- (h) Selection could be made on the basis of:
- (1) the capacity payment, which covers the costs of debt, equity and the engineering, procurement and construction (EPC) contract; is typically the component in which there is the greatest scope for efficiency by the developer. Such an approach requires the *energy* component to be fixed in some way, e.g:
 - (i) fix target thermal efficiency;
 - (ii) fix terms of fuel supply agreement; or
 - (iii) cap fuel cost pass-through to an appropriate price index.
 - (2) a weighted average of the capacity and *energy* prices, producing a levelised per kWh price. Computing this levelised price requires a variety of assumptions to be made - notably the capacity utilisation factor over the lifetime of the *plant*. Such assumptions shall be made explicit to all bidders in advance of bid submission.
- (i) The *Commission* may also allow for bidding on the basis of other objective parameters (e.g. target availability). It is noted that while including a number of objective selection criteria does not reduce the objectivity of the selection process, it can complicate final bid evaluation. To mitigate this difficulty an evaluation model will be constructed to facilitate the selection process.

9.2.2 Project specification

- (a) Project specification can be described as being relatively "open" or "closed" according to the extent to which the procurement procedure allows bidders flexibility in proposing non-price project characteristics (e.g. size, location, type of *plant*).
- (b) The project specification shall be relatively closed.
- (c) In order to address the issue of project specification whilst retaining objective selection procedures; an adequate technical proposal shall be used as a "cut-off" criterion at the pre-selection stage before the price criterion is applied.

9.2.3 Post-Bid negotiations

- (a) The *Commission* recognises that some degree of post-bid discussion leading up to contract signature is inevitable. However, post-bid negotiations on the selection criterion or other factors materially affecting profitability shall not be allowed.
- (b) All prohibitions on post-bid negotiations shall be made explicit to all bidders in advance of bid submission. This provision shall be enforceable through the use of a bid bond in order to encourage bidders to approach contract signature in good faith.

9.3. MARKET RULES

9.3.1 Core rules

- (a) The two core documents that define the rights and responsibilities of market participants are typically the *Code* and the *market rules* themselves.
- (b) As the structure of the electricity industry in Kenya evolves towards a wholesale power market it will require the drafting of a range of documents complementary to the *Code* determining procedures for such matters as scheduling and *dispatch*, price determination and administration of the wholesale power market.
- (c) All participants in the future **wholesale power market** must agree to abide by the provisions of the *market rules*, which will specify commercial arrangements in the market.
- (d) There will therefore be close coordination between the *Code* and the *market rules*.

9.3.1 Rules for the short term

- (a) In the short term, wholesale power purchases and associated commercial issues will be governed solely by the PPAs in place between the off-taker and the generating companies. There is therefore no need for commercial arrangements between market participants to be set out in *market rules*.
- (b) The PPAs will also govern most of the technical provisions alongside those covered by the *Code*.
- (c) For completeness, Schedule S9.1 includes the process for planning for additions to capacity, and specifies procedures for ensuring least cost *dispatch* in order to eliminate any discretion over what constitutes least cost *dispatch* to the off-taker.

SCHEDULES TO CHAPTER 9

TABLE OF CONTENTS

| | Page |
|---|------|
| S9.1 POWER GENERATION PLANNING AND SECURITY STANDARD | 254 |
| S9.1.1 Introduction | 254 |
| S9.1.2 Load Forecast | 254 |
| S9.1.3 Planning Criteria | 255 |
| S9.1.4 Estimation of Peaking Capacity | 256 |
| S9.1.5 Generation Plant Norms | 259 |
| S9.1.6 Economic Parameters | 259 |
| S9.1.7. Plant Economic Life | 259 |
| S9.1.8 Cost of Un-Served Energy | 260 |
| S9.1.9 Evaluation of Planning Studies | 260 |
| S9.1.10 Power Generation Security Standards | 260 |
| S9.1.11 Capacity Reserve | 261 |
| S9.2 OUTLINE OF COMPETITIVE TENDERING PROCESS | 261 |
| S9.2.1 Introduction | 261 |
| S9.2.2 Demonstration of need for and type of new capacity | 261 |
| S9.2.3 Determine Scope of competition and issue RFQ | 261 |
| S9.2.4 Pre-Qualification | 262 |
| S9.2.5 Issuance of model tender documents and soliciting of views | 262 |
| S9.2.6 Issue RFP | 263 |
| S9.2.7 Pre-Selection of bidders - project viability | 263 |
| S9.2.8 Select winner | 263 |
| S9.2.9 Contractual commitment | 264 |
| S9.2.10 Implementation and pass through of costs into tariffs | 264 |

SCHEDULES TO CHAPTER 9

S9.1 POWER GENERATION PLANNING AND SECURITY STANDARD

S9.1.1 Introduction

This Schedule frames the guidelines for the long, medium and short term planning strategy for least cost planning to serve the demand of electricity in Kenya at the specified level of *voltage*, frequency and reliability by *consumers*. This standard comprising the following sections formulates the procedure for planning future additions to generating capacity in Kenya:

- (1) Load forecast.
- (2) Planning criteria.
- (3) Estimation of peaking capacity.
- (4) *Generation plant* norms for planning purposes.
- (5) Economic parameters.
- (6) *Plant* economic life.
- (7) Cost of un-served *energy*.
- (8) Evaluation of planning studies.
- (9) Power *generation* security standards.
- (10) Capacity reserve.

S9.1.2 Load Forecast

- (a) The forecasting of load demand and *energy* shall be done as follows:
 - (1) Long term forecasting *connected* with load growth, supply and demand side management resources for periods of 15 to 20 years.
 - (2) Medium term forecasting covering a period of 5 to 15 years.
 - (3) Short term forecasting connected with seasonal weather variations in a year, weekly or daily load forecast, etc.
- (b) The forecasting of peak load demand and *energy* requirements shall be done by the various *distribution network service providers* and *public electricity suppliers* in their respective areas of *supply* for each category of *loads* for each of the succeeding ten years of the planning period. The *distribution network service providers* and *public electricity suppliers* shall submit such forecasts annually by 1st day of March each year to *the transmission network service provider* along with data, methodology and assumptions on which the forecasts are based.
- (c) *The transmission network service provider* shall integrate the load forecasts submitted by each of the *distribution network service providers* and *public electricity suppliers* and determine the long-term load forecasts for ten years for the nation. *The transmission network service provider* may also review the methodology and assumptions used by the *distribution network service providers* and *public electricity suppliers* in making the load forecast.

- (d) The overall *load* forecast shall be used to determine the capacity of *generation, transmission and distribution systems* and *energy* forecasts to determine the type of *generating plants* required (i.e., peaking, intermediate or base *load* units). Peak power requirements determine the utility's investment in *generation* and the resultant *transmission* capacity additions.
- (e) Long term (20 years) forecasts are used for:
- (1) *Reinforcement* planning of *generation, transmission and distribution systems*,
 - (2) Establishing future fuel requirement and logistics,
 - (3) Examining the availability of natural fuel and water resources,
 - (4) Development of trained human power.
- (f) Mid term forecasts are aimed at determining yearly or monthly peak, minimum *load* and *energy* requirements for one to five years for the purpose of:
- (1) Maintenance scheduling of *generation and transmission plant*,
 - (2) Scheduling of multi-purpose hydroelectric power *plants* for irrigation, cooling water requirements for thermal power *plants* etc., apart from *generation*,
 - (3) Power exchange contracts with neighbouring country utilities,
 - (4) Annual planning and budgeting for fuel requirements and other operational requirements.
- (g) Short-term forecasts on daily, weekly and monthly basis are required for the following purpose of
- (1) Unit *commitment* and economic *dispatch* calculations,
 - (2) Maintenance scheduling updates,
 - (3) Assessing *load* flows,
 - (4) Spinning reserve calculations,
 - (5) Short-term interchange schedules with neighbouring systems,
 - (6) System security analysis
 - (7) *Load* management scheduling,
 - (8) Optimisation of fuel storage.
- (h) The planning process shall take into account the existing *generation* capacity, allocation from central sector *generation* and other *generation* to evolve the net additional requirement of power over the years of the planning period. The planning process shall consider an extended study period of 10 years beyond the base period of 20 years to review different types and capacities of *generating plants* at the end of base period.

S9.1.3 Planning Criteria

- (a) **Least Cost Planning:** - Least Cost Planning shall be done with a planning strategy to provide reliable *supply* of power at the lowest possible overall cost considering both supply side and demand side options. The various options that are applicable at the time of planning as found economical and feasible, shall be considered. Some of the typical options are suggested below:

(1) Supply Side Options

- (i) Conventional *plants* such as coal, thermal, geothermal, nuclear.
- (ii) Combined cycle combustion gas turbines.
- (iii) Large hydro.
- (iv) Small Hydro, Wind power, Solar Power
- (v) Captive power *generating plants* feeding surplus *energy* to the *grid*.
- (vi) Biomass gasification.
- (vii) Upgrading and modernising of existing power *plants*.
- (viii) Diesel Power *generation*.
- (ix) Improving power station efficiency.
- (x) Out sourcing of power from other countries and *reinforcing* of inter-regional power *grid*.

(2) Demand Side Options

- (i) *Load* management.
- (ii) Time of the *day metering*.
- (iii) Achieving end use *energy* efficiency by use of more efficient *consumer* appliances/motors.
- (iv) Checking pilferage.
- (v) Improving the *load power factor*.

- (b) The process of planning shall be such that the same should meet the needs of *consumers' energy* requirement at the lowest possible cost, should be environmentally benign, and acceptable to the public. For an investment to be at the least possible cost, the life cycle costs shall be considered. These shall include capital cost, interest on capital, fuel costs, and operations and maintenance costs etc.
- (c) **Project evaluation:** For the purpose of evaluation, all options, whether supply or demand, should be assessed in a comparable and consistent manner. During such evaluation, environmental costs shall also be considered. The net present value of the revenue requirements for a chosen resource option should be calculated for the complete life cycle of the option.
- (d) **Determination of the type of Generation Plant Required:** The anticipated *load* curve is drawn and the area below the curve is filled up by available *generation* by suitable scheduling. The *generation facilities* are classified as hydro, thermal, geothermal, gas turbines, diesel electric and others.

S9.1.4 Estimation of Peaking Capacity

- (a) **Peaking availability (existing stations):** The peaking availability of the existing hydro-electric power stations, thermal power stations and diesel electric power stations furnished by the power companies in Kenya and the allocated share of the central sector power stations shall form the basis of evaluating the existing peaking availability.

(b) **Peaking capability of new generating stations:** The peaking availability of generating units shall be estimated on the basis of the norms indicated in the following clauses:

(1) Norms for peaking capability of thermal stations and gas based power stations:

(i) The peaking capability of thermal generating units can be computed as below:

| Unit Capacity (MW) | OUTAGE RATES | | |
|-----------------------|--------------------|-------------------|--------------------|
| | Planned (PMR) % | Forced (FOR) % | Partial (POR) % |
| Above 50 MW | 10.0 | 14.0 | 9.0 |
| 50 MW & Below | 10.0 | 16.0 | 14.0 |

Note:

$$CAF = 100 - (PMR + FOR + POR)$$

$$PAF = CAF - CAF * AC$$

Where

| | | |
|-----|---|---|
| CAF | = | Capacity Availability Factor |
| PCF | = | Plant capacity factor |
| PMR | = | Planned Maintenance Rate |
| FOR | = | Forced Outage Rate |
| POR | = | Partial Outage Rate |
| AC | = | Auxiliary consumption as per <i>generating plant</i> norms. |

(ii) Peaking capability of gas stations can be computed as below:

The gas-based power stations are grouped into two categories namely base *load* stations and peak *load* stations. The base *load* stations are normally combined cycle gas turbine power *plant* (CCGT), which have Gas Turbine units and steam turbine units. The peak *load* stations are open cycle gas turbine *plants*, which are generally used for meeting peak *load*, for about 8 hours in a *day*, at 80% of their rated capacity.

(iii) For combined cycle gas based power station, the peaking capability would be as given below:

| Unit Capacity (MW) | OUTAGE RATES | | |
|---|--------------------|-------------------|--------------------|
| | Planned (PMR) % | Forced (FOR) % | Partial (POR) % |
| Gas Turbine units (Open cycle) | 15 | 10 | 10 |
| Gas Turbine units (Combined cycle) | 15 | 10 | 10 |
| Steam Turbine units (Combined Cycle) | 15 | 10 | 10 |

Note:

$$CAF = 100 - (PMR + FOR + POR)$$

$$PAF = CAF - CAF * AC$$

(2) Auxiliary consumption for thermal and gas based power stations:

The following auxiliary consumption figures for various types of power *plants* shall be considered for determining peaking capacity.

(i) Thermal power *plants*:

| Sl.No | Unit Size (MW) | With Cooling Tower % | Without Cooling Tower % |
|-------|--|----------------------------|-------------------------------|
| (i) | Below 200 / 210 MW | 9.5 | 9.0 |
| (ii) | 250 MW & Above (Electrically Driven Pumps) | 9.5 | 9.0 |

Note: The auxiliary *energy* consumption of *generating stations* with steam driven boiler feed pumps shall be reduced by 1.5%

(ii) Gas & Naphtha based stations:

| SN | Plant Configuration | Auxiliary Consumption % |
|------|---------------------|-------------------------|
| (i) | Combined Cycle | 3.0 |
| (ii) | Open Cycle | 1.0 |

(During the stabilisation period, normative auxiliary consumption shall be reckoned at 0.5% over and above the figures specified above).

(3) Norms for peaking capability of hydro stations:

Peaking capability of hydroelectric power stations can be computed as follows:

$$CAF = 100 - (CM + FOR) = 92.5\%$$

$$PCF = CAF - CAF * AC = 92\%$$

Where

| | | |
|-----|---|---|
| CAF | = | Capacity Availability Factor |
| PCF | = | <i>Plant</i> capacity factor |
| PMR | = | Planned Maintenance Rate |
| FOR | = | Forced Outage Rate |
| POR | = | Partial Outage Rate |
| AC | = | Auxiliary consumption as per <i>generating plant</i> norms. |

Where:

| | | | | |
|-----|---|------------------------------|---|-------|
| CM | = | Capital maintenance factor | = | 3% |
| FOR | = | Forced outage rate factor | = | 4.5% |
| AC | = | Auxiliary consumption factor | = | 0.5% |
| CAF | = | Capacity availability factor | = | 92.5% |
| PCF | = | Peaking capability factor | = | 92 % |

S9.1.5 Generation plant norms

- (a) While planning the required *generation*, the prevailing norms as per the *transmission network service provider's* guidelines shall be followed.

S9.1.6 Economic parameters

The cost estimate shall reflect economic conditions as on the base year. The increase in cost over time till the project is completed shall be at the rate of inflation prevailing over the period of each expenditure and excludes taxes and statutory levies. Discounting for calculating cumulative present cost for each scheme shall be done at an annual rate of 12%.

S9.1.7.Plant economic life

The economic life of *generating plants* may be assumed as follows for the planning, from time to time.

| Plant type | Life in years |
|--|---------------|
| Hydro Electric | 50 |
| Geothermal Electric | 25 |
| Thermal Electric and waste heat recovery boilers/ <i>plant</i> | 20 |
| Diesel Electric and Gas <i>plants</i> | 15 |

S9.1.8 Cost of Un-Served Energy:

- (a) Value of un-served *energy* (i.e. the loss to economy if a kWh of *energy* required by *consumers* can not be supplied) shall be considered in the economic analysis for the least cost *generation* expansion plan. Suitable pricing for such power outage costs shall be adopted from available studies applicable for Kenya.

S9.1.9 Evaluation of planning studies

- (a) Suitable computer programs shall be adopted to arrive at a least cost *generation* expansion plan. The following guidelines are to be broadly followed in the estimation:
- (1) The following *generation* capacity addition scenarios to be considered in the context of demand forecast:
 - (i) Mixed Hydro/Thermal,
 - (ii) Thermal only,
 - (iii) Diesel only and
 - (iv) Mixed base/peak *generation*.
 - (2) For each of the above, determine by simulation, the timing of the new *generating plants* during the planning period in order to meet the Security Standards.
 - (3) Simulate the system operation in order to obtain the average annual *energy* production from each *plant*.
 - (4) Compute the cumulative present value cost incorporating the capital costs, fixed and variable operation and maintenance costs, fuel costs and un-served *energy* costs, for each scenario over the planning period.
 - (5) Compare the present value cost of each scenario with that of the others to arrive at the least cost scenario.
 - (6) Calculate the Long Run Marginal Cost (LRMC) for the least cost scenario as follows:
 - (i) For each year of the plan period determine incremental cost of *generation*, *energy* requirement, *energy* generated, incremental net *energy* generated, loss of *load* probability in hours & un-served *energy*.
 - (ii) Reduce the incremental cost of *generation* to the net present value.
 - (iii) Long run marginal cost in KShs/kWh is given by the following equation:

$$LRMC \text{ (KSh/kWh)} = \frac{\text{Total NPV of Incremental Cost of Generation (KSh)}}{\text{Incremental Net Energy Generation (kWh)}}$$

S9.1.10 Power generation security standards

- (a) Adequate reserve capacity shall be available to ensure sufficient *generation* reserve to meet the system *load* even if two of the largest units in the system are out of service, or to meet the non availability of adequate hydro electric *generation* due to poor weather.
- (b) The peaking capacities and the *energy generation* capacities, availability of power *plants* on which the power and *energy* balance studies are based shall be determined on the basis of the capacity reserve specified in the following clause.

S9.1.11 Capacity reserve

- (a) Loss of Load Expectation (LOLE) of 10 *days* per year % and no more than 0.10% un-served *energy* shall be used for planning models.
- (b) This shall mean that for up to 10 *days* per year the *power system* may experience shortages of *generation capacity*.
- (c) Un-served *energy* shall be limited to 0.10% of the average annual *energy*.
- (d) A contingency reserve margin equal to 15% of the system peak load shall be planned to take care of fluctuations in the availability of hydro electric *generation* during critical period of a dry year, and to account for outage of units, power station equipment, in order to maintain security and integrity of system.

S9.2 OUTLINE OF COMPETITIVE TENDERING PROCESS**S9.2.1 Introduction**

- (a) This section sets out the suggested structure for a competitive *Generation Capacity Procurement Tendering Procedure* with the objective of providing guidelines to be followed in the procurement of additional *generation capacity*. The outline procedure comprises the following stages:
 - (1) Demonstration of need for and type of new capacity;
 - (2) Determination of the scope of competition and issuance of the Request For Qualification (RFQ);
 - (3) Pre-Qualification;
 - (4) Issuance of model tender documents and soliciting of views;
 - (5) Issuance of Request For Proposals (RFP);
 - (6) Selection of winning bid;
 - (7) Contractual commitment, and
 - (8) Implementation and pass-through of costs into tariffs.
- (b) The following is a brief description of the key issues to be addressed at each stage.

S9.2.2 Demonstration of need for and type of new capacity

- (a) During this stage, the latest version of the *Least Cost Power Development Plan* in which is specified the planning procedures shall be reviewed by the *Commission*. The *Commission* will:
 - (1) verify the need for new capacity based on the load forecast;
 - (2) ensure all available options have been considered including demand side measures as well as loss reduction; and
 - (3) review assessment of alternatives to ensure selected option will represent best value for money i.e. it is the least cost expansion plan.
- (a) If found satisfactory, the *Commission* will accept the need for new capacity and the preferred option, and the next stage of the procurement procedure will begin.

S9.2.3 Determine Scope of competition and issue RFQ

- (a) During this stage, the purchasing entity will issue a draft Request for Qualifications (RFQ) to the *Commission* for approval. This will cover project scope, the proposed

method of distributing the RFQ and pre-qualification criteria. The *Commission* will:

- (1) Review project scope to ensure this is not drawn unnecessarily narrowly to exclude potentially attractive proposals with regard to:
 - (i) Adequacy of the size and location of *plant*
 - (ii) The appropriateness of the technology of the *plant* and fuel source
 - (2) Review RFQ process to ensure strongest possible list of bidders is attracted. This will include issues such as the publication of the RFQ
 - (3) Ensure pre-qualification criteria are transparent and justifiable.
- (b) Once the draft RFQ has been approved by the *Commission* and expressions of interest received, the next step will be to apply the pre-qualification criteria.

S9.2.4 Pre-qualification

- (a) The objective of the pre-qualification stage is to ensure that all pre-qualified bidders meet agreed minimum standards. Bidders, who fail to meet threshold criteria on agreed key characteristics, are eliminated to allow subsequent use of objective selection criterion. The pre-qualification criteria typically relate to:
- (1) the financial capacity of the bidder e.g. balance sheet strength;
 - (2) technical expertise and experience as a *generation* capacity developer and/or operator;
 - (3) certain prohibitions (e.g. on a subsidiary of the contracting party submitting a tender); and
 - (4) possibly, the payment of an entry fee
 - (5) the pre-qualified bidders meeting prescribed licensing criteria.
- (b) Once the pre-qualification is complete, model tender documents should be sent to pre-qualified bidders.

S9.2.5 Issuance of model tender documents and soliciting of views

- (a) In order to give bidders limited flexibility with respect to key project parameters such as the size and type of *plant* they will receive detailed information relating to the proposed *plant*, including technical specifications, in advance of submitting their bid. The key project parameters will be set out in the tender documents, and shall include:
- (1) Operational/commercial requirements
 - (2) The criteria to be used for project selection:
 - (i) A model PPA (with the sections relating to the selection criteria to be completed following the selection of the successful bidder)
 - (ii) *Government* guarantees (if any), hypothecated revenues or any other special financial and/or commercial arrangements.
- (b) The object of releasing this information in draft form at this stage is to give pre-qualified bidders the opportunity to give their views on these project parameters. In the event that the closed approach to project specification is used, this stage allows the procuring authority the opportunity to take advantage of innovative ideas that bidders may have (with respect to site, size and technology) and of the requirements

bidders may have (for example, with respect to *government* guarantees). In the event that an investors' conference is held, the views of bidders will also be solicited during the conference.

- (c) Once any amendments have been made to the tender documents following this stage, the Request for Proposals (RFP) will be issued.

S9.2.6 Issue RFP

- (a) The RFP sent to the pre-qualified bidders will contain:
 - (1) the finalised bid documents listed above;
 - (2) an explanation of the selection methodology; and
 - (3) an explanation of any other requirements for pre-selection (e.g. demonstration of financial commitment to the project, submission of a technical proposal, posting of a bid bond).
- (b) Clause S9.2.6(a)(3) relates to the issue of pre-selection, which is discussed in the following section.

S9.2.7 Pre-Selection of bidders - project viability

- (a) A pre-selection stage may be included prior to final selection in order to allow the use of additional "cut off" criteria which may relate to the financial or technical viability of the project.
- (b) In all cases, bidders will be required to demonstrate sufficient financial commitment to the project by the (pre)selection stage. The type of commitment required will depend on the type and source of financing without the contracting authority being prescriptive about the financial structure of the bidder. It is noted that this may not be easy to demonstrate definitively, and judgement will have to be exercised by the contracting authority.
 - (1) In terms of equity financing, the lead developer should be able to demonstrate commitment from the board and sufficient balance sheet strength.
 - (2) In terms of debt, (e.g. from banks, MLAs or ECAs) it is most unlikely that commitment will be given until the project is selected, but some indication of willingness to lend, such as a letter of intent, may be provided.
 - (3) A further means of demonstrating willingness to commit would be the submission of a bid bond, which would be forfeited in the event that the bidder is selected but fails to reach financial close.
- (c) Another form of pre-selection may involve scrutiny of a technical proposal.
- (d) Failure to demonstrate that reasonable steps have been taken to secure financing, or to submit an adequate technical proposal, will at this stage result in exclusion of the bid.

S9.2.8 Select winner

- (a) The selection of winning bid (from pre-selected bidders) shall be a transparent process based on the procedures and criteria discussed in detail in the preceding sections.

S9.2.9 Contractual commitment

- (a) Once the winning bid has been selected, there shall be no post-bid negotiations on the selection criteria or other factors substantively affecting the profitability of the project.
- (b) The following tasks must be undertaken prior to contractual commitment:
 - (1) Securing financing for the project.
 - (2) If deemed necessary, there may also be some discussion about the tender documents and/or project specifications, with due regard to paragraph (a) above.
- (c) Failure to sign the contract within a certain period could result in forfeiture of the bid bond.
- (d) The *Commission* will not be a signatory to the contract itself. However, the *Commission* will give its approval prior to signature acknowledging that to the best of its knowledge the prescribed competitive procedure has been followed in signing the contract with the preferred bidder.
- (e) The *Commission* shall indicate to the procuring authority and to the developer that it considers that the tendering procedure has been conducted in the prescribed fashion. The pass-through costs of the project shall in turn be passed on to the end users in the regulated end-user-tariffs for the duration of the contract, as discussed in the next section.
- (f) The *Commission* will decline to give the assurance of passing through the costs of the contract in full to end users if it has reasonable concerns about the contracting procedure.

S9.2.10 Implementation and pass through of costs into tariffs

- (a) The process of constructing the *plant* will commence after the contract has been signed.
- (b) There will be penalty clauses specified in the contract for failing to commission the *plant* within the specified timescale.
- (c) Once payments begin to be made by the off-taker to the developer under the PPA, the *Commission* will consider whether these costs should be passed through to final *consumers* in regulated tariffs. If the *Commission* has given an indication that the prescribed procedures have been followed, it will pass the costs through for the duration of the contract.
- (d) The *Commission* will subsequently disallow costs only if new information reveals that there was a serious contravention of the guidelines. This is a very serious step, since it would undermine the ability of the off-taker to meet its obligations under the contract, hence will be resorted to only after satisfactory investigations confirm the contravention of the guidelines.
- (e) The *Commission* will not disallow costs because, for example, of changes in demand and supply conditions that were not anticipated at time of procurement and which mean that the project is no longer competitive.

CHAPTER 10 RING FENCING

TABLE OF CONTENTS

| | Page |
|---|-------------|
| 10.1 PURPOSES AND AIMS | 266 |
| 10.2 INITIAL RING FENCING OBLIGATIONS | 266 |
| 10.3 REVIEW OF INITIAL RING FENCING OBLIGATIONS | 267 |
| 10.4 COMPLIANCE PROCEDURES AND COMPLIANCE REPORTING | 268 |

CHAPTER 10 RING FENCING

10.1 PURPOSES AND AIMS

This Chapter of the *Code*:

- (a) establishes ring fencing obligations which shall be complied with by *network service providers* and the *System Operator*;
- (b) requires *network service providers* to establish and maintain separate accounts for *network services* in accordance with guidelines issued by the *Commission* from time to time;
- (c) requires *network service providers* to allocate costs shared between different accounts in a fair and reasonable manner;
- (d) requires the *System Operator* to establish and maintain separate accounts in accordance with the *Code* and with guidelines issued by the *Commission* from time to time;
- (e) requires the *System Operator* to allocate costs shared between different accounts that have been established for the control of the *power system* in a fair and reasonable manner;
- (f) requires the *System Operator* to perform his functions and obligations so that all *network users* and *consumers* are treated equitably;
- (g) ensures that *confidential information* provided by a *network user* to a *network service provider* or the *System Operator* is used only for the purposes for which it was provided and is not disclosed to any other person other than in accordance with the *Code*; and
- (h) requires *network service providers* and the *System Operator* to establish procedures to ensure compliance with the ring fencing obligations as set out in this Chapter 10 and in accordance with guidelines issued by the *Commission* from time to time.

10.2 INITIAL RING FENCING OBLIGATIONS

- (a) A *network service provider* shall comply with the following:
 - (1) establish and maintain a separate set of accounts in respect of *network services*;
 - (2) in respect of a *distribution network service provider* who is also a *public electricity supplier*, establish and maintain a separate set of accounts in respect of his activities as a *public electricity supplier*;
 - (3) establish and maintain a separate consolidated set of accounts in respect of his entire business;
 - (4) allocate any costs that are shared between an activity that is covered by a set of accounts described in clause 10.2(a)(1) and 10.2(a)(2) and any other activity according to a methodology for allocating costs that is consistent with the principles in clauses 5.2.1, 5.2.2, 5.5.2 and 5.5.3 and is otherwise fair and reasonable;
- (b) In complying with clauses 10.2(a)(1), (2), (3) and (4) a *network service provider* shall:
 - (1) if the *Commission* has published general accounting guidelines for *network service providers* which apply to the accounts being prepared, comply with those guidelines; or

- (2) if the *Commission* has not published such guidelines, comply with guidelines prepared by the *network service provider* and approved by the *Commission* or, if there are no such guidelines prepared by the *network service provider*, comply with such guidelines (if any) as the *Commission* advises the *network service provider* apply to that *network service provider* from time to time.

Such guidelines may, amongst other things, describe the principles for the allocation of cost between activities and require the accounts to contain sufficient information, and to be presented in such a manner, as would enable the *Commission* to meet its objectives for the regulation of *public electricity suppliers* and *network services*.

- (c) The *Commission* may determine that information provided by a *network user* to a *network service provider* or representative under this Chapter 10 is *confidential information* and the provisions of clause 11.6 shall apply to that information.

- (d) The *System Operator* shall comply with the following:

- (1) establish and maintain a separate set of accounts in respect of the functions, obligations and responsibilities of the *System Operator* in accordance with the *Code* and the requirements of the *Commission*;
- (2) establish and maintain a separate consolidated set of accounts in respect of his entire business;
- (3) allocate any costs that are shared between an activity that is covered by a set of accounts described in clauses 10.2(d)(1) and 10.2(d)(2) and any other activity according to a methodology for allocating costs that is fair and reasonable;
- (4) establish policies and procedures to ensure that the *System Operator* carries out his functions and obligations under the *Code* in a manner which is fair and equitable to all *Code Participants* and *consumers*;

- (e) In complying with clauses 10.2(d)(1), (2) and (3) the *System Operator* shall:

- (1) if the *Commission* has published general accounting guidelines for the *System Operator* which apply to the accounts being prepared, comply with those guidelines; or
- (2) if the *Commission* has not published such guidelines, comply with guidelines prepared by the *System Operator* and approved by the *Commission* or, if there are no such guidelines, comply with such guidelines (if any) as the *Commission* advises the *System Operator* apply to the *System Operator* from time to time.

Such guidelines may, amongst other things, describe the principles for the allocation of cost between activities and require the accounts to contain sufficient information, and to be presented in such a manner, as would enable the *Commission* to verify that these are fair and reasonable.

- (f) The *Commission* may determine that information provided by a *network user* to the *System Operator* or a representative of the *System Operator* under this Chapter 10 is *confidential information* and the provisions of clause 11.6 shall apply to that information.

10.3 REVIEW OF INITIAL RING FENCING OBLIGATIONS

- (a) The *Commission* may review and modify any guidelines referred to in clauses 10.2(b) and 10.2(e) having regard to the following:

- (1) the objectives and functions of the *Commission* pursuant to the *Act* and set out in clause 1.5;

- (2) ensuring that a *network service provider* who is also a *public electricity supplier* does not have regard to the interests of his business as a *public electricity supplier* (if any) or an *associate* in priority to the interests of other *Code Participants*, other than the *Commission*, with respect to the supply or purchase of services;
 - (3) ensuring that the *System Operator* does not have regard to the interests of his business as a *transmission network service provider* or an *associate* in priority to the interests of other *Code Participants*, other than the *Commission* with respect to the supply or purchase of services; and
 - (4) ensuring the ring fencing obligations do not impose unreasonable compliance costs on the *network service provider*, the *System Operator* and any associates.
- (b) The effect of the review contemplated by clause 10.3(a) may include either the extension or limitation of the initial ring fencing obligations in clause 10.2 as applies to a *network service provider* or the *System Operator*.

10.4 COMPLIANCE PROCEDURES AND COMPLIANCE REPORTING

- (a) Each *network service provider* and the *System Operator* shall establish and maintain appropriate internal procedures to ensure he complies with his obligations under this Chapter 10. The *Commission* may require any *network service provider* or the *System Operator* to demonstrate the adequacy of these procedures upon reasonable notice. However, any statement made or assurance given by the *Commission* concerning the adequacy of any *network service provider's* or the *System Operator's* compliance procedures does not affect their respective obligations under this Chapter 10.
- (b) The *Commission* may appoint a “*Compliance Agent*” to report to the *Commission* on the compliance with and adequacy of the provisions of the *Code* and the guidelines to meet its objectives for the regulation of those services.
- (c) Each *network service provider* and the *System Operator* shall provide a report to the *Commission*, at reasonable intervals determined by the *Commission*, describing the measures each has undertaken to ensure compliance with his obligations under this Chapter 10, and providing an accurate assessment of the effect of those measures.
- (d) Each *network service provider* and the *System Operator* shall provide a report of any breach of any of their obligations under this Chapter 10 to the *Commission* immediately upon becoming aware that the breach has occurred.
- (e) The *Commission* and the *Compliance Agent* may require a *network service provider* and the *System Operator* to make their *books* available for inspection by the *Commission* at all reasonable times and on reasonable notice so that the *Commission* may determine whether the measures undertaken by the *network service provider* and the *System Operator* to ensure compliance with their respective obligations under this Chapter 10 are adequate.
- (f) The *Commission* and the *Compliance Agent* may:
 - (1) inspect, and may make copies of, or take extracts, from any of the *books*;
 - (2) take possession of any of the *books*; and
 - (3) retain possession of any of the *books* for so long as necessary.

CHAPTER 11 ADMINISTRATIVE FUNCTIONS**TABLE OF CONTENTS**

| | Page |
|--|------|
| 11.1 GENERAL | 271 |
| 11.1.1 Application | 271 |
| 11.1.2 Purpose | 271 |
| 11.2 DISPUTE RESOLUTION | 271 |
| 11.2.1 Application and guiding principles | 271 |
| 11.2.2 Code Participant’s dispute management systems | 272 |
| 11.2.3 First stage dispute resolution processes | 273 |
| 11.2.4 Second stage dispute resolution processes | 273 |
| 11.2.5 The Dispute Resolution Panel | 274 |
| 11.2.6 Legal representation | 275 |
| 11.2.7 Cost of dispute resolution | 275 |
| 11.2.8 Effect of resolution | 275 |
| 11.2.9 Recording and publication | 276 |
| 11.2.10 Appeals | 276 |
| 11.2.11 Limitation of Liability | 276 |
| 11.2.12 Review by the Commission of dispute resolution procedures | 276 |
| 11.3. CODE CHANGE | 276 |
| 11.3.1 Code Change Panel | 276 |
| 11.3.2 How the Code may be changed | 277 |
| 11.3.3 Referral of matters to CCP | 278 |
| 11.3.4 Consideration and recommendations by the CCP | 278 |
| 11.3.5 Consideration of CCP recommendations by the Commission | 280 |
| 11.3.6 Adoption and implementation | 280 |
| 11.3.7 “Fast-track procedures” | 280 |
| 11.3.8 Notice by publication | 281 |
| 11.3.9 CCP indemnity | 281 |
| 11.4 TRANSITIONAL PROVISIONS | 281 |
| 11.4.1 Meaning of transitional provisions | 281 |
| 11.4.2 When the Commission may grant a transitional provision or extend a transitional provision | 281 |
| 11.4.3 Decisions by the Commission regarding proposed transitional provisions | 282 |
| 11.4.6 Notice by publication | 282 |
| 11.5 ENFORCEMENT | 282 |

| | |
|--|-----|
| 11.5.1 Investigations | 282 |
| 11.5.2 Right of entry and inspection | 283 |
| 11.5.3 The functions of the Commission | 283 |
| 11.5.4 Procedures concerning alleged breaches of the Code | 283 |
| 11.5.5 Sanctions | 283 |
| 11.5.6 Action by the Commission to give effect to its orders | 283 |
| 11.5.7 Actions by agents, employees or officers of Code Participants | 284 |
| 11.5.8 Publication | 284 |
| 11.5.9 System security directions | 284 |
| 11.6 CONFIDENTIALITY | 285 |
| 11.6.1 Confidentiality | 285 |
| 11.6.2 Exceptions | 285 |
| 11.6.3 Conditions | 286 |
| 11.6.4 Application of confidentiality provisions to the Commission | 286 |
| 11.6.5 Indemnity to the Commission | 286 |
| 11.6.6 Code Participant information | 287 |
| 11.6.7 Information on Code bodies | 287 |
| 11.7 MONITORING AND REPORTING | 287 |
| 11.7.1 Monitoring objectives | 287 |
| 11.7.2 Code Participants’ reporting requirements and monitoring standards | 287 |
| 11.7.3 Use of information | 289 |
| 11.7.4 Reporting | 289 |
| 11.7.6 Recovery of reporting costs | 290 |
| 11.8 SYSTEM PLANNING AND RELIABILITY COUNCIL | 290 |
| 11.8.1 Purpose of the System Planning and Reliability Council | 290 |
| 11.8.2 Constitution of the System Planning and Reliability Council | 291 |
| 11.8.3 Reliability review process | 291 |
| 11.9 CODE CONSULTATION PROCEDURES | 293 |

CHAPTER 11 ADMINISTRATIVE FUNCTIONS

11.1 GENERAL

11.1.1 Application

This Chapter applies to all *Code Participants*.

11.1.2 Purpose

This Chapter describes the key processes associated with the administration of the *Code*, being the following:

- (a) the procedures for resolving disputes between *Code Participants*;
- (b) the method of changing the *Code*;
- (c) the method by which transitional provisions from obligations of the *Code* may be obtained;
- (d) powers of enforcement in relation to the *Code*;
- (e) confidentiality provisions governing all *Code Participants*;
- (f) monitoring and reporting powers of the *Commission*;
- (g) structure and responsibilities of the *System Planning and Reliability Council*; and.
- (h) *Code consultation procedures*.

11.2 DISPUTE RESOLUTION

11.2.1 Application and guiding principles

- (a) The dispute resolution regime provided for in this clause 11.2 applies to any dispute which may arise between any *Code Participants* (and for the purposes of clause 11.2, *Code Participant* includes *connection applicants*) as to:
 - (1) the application or interpretation of the *Code*;
 - (2) where a contract between two or more *Code Participants* provides that the dispute resolution procedures under the *Code* are to apply, to any disputes under or in relation to that contract with respect to the application of the *Code*;
 - (3) the failure of any *Code Participants* to reach agreement on a matter where the *Code* requires agreement or requires the *Code Participants* to negotiate in good faith with a view to reaching agreement;
 - (4) a dispute concerning the proposed access arrangements or *connection agreements* of a *connection applicant*; or
 - (5) the payment of monies under or concerning any obligation under the *Code*.
- (b) An amount which a *Code Participant* (in this clause called the “defaulting *Code Participant*”) is required to pay to another *Code Participant* (in this clause called the “claimant”) is due under the *Code*:
 - (1) in the case of an amount which is stated under the *Code* to be payable notwithstanding a dispute regarding the amount, at the time specified for payment in the *Code*;
 - (2) in any other case, provided the claimant has notified the defaulting *Code Participant* of the claim, whether through issuing, in accordance with the *Code*, a statement or bill or other notice specifying the amount and the due date for payment:

- (i) if the defaulting *Code Participant* does not give notice to the claimant that he disputes the amount claimed as payable on or before the due date for payment, on the due date for payment specified in the statement, bill or other notice; or
 - (ii) if the defaulting *Code Participant* does give notice to the claimant that he disputes the amount claimed as payable on or before the due date for payment, on the date for payment which is then agreed between the defaulting *Code Participant* and the claimant or which is otherwise determined under the dispute resolution procedures set out in clause 11.2.
- (c) The due date for payment specified in the statement, bill or other notice referred to in clause 11.2.1(b) shall not be:
 - (1) prior to the expiry of any applicable period of notice required under the *Code*; or
 - (2) if no period of notice is specified, less than 5 *business days* after the date the claimant issues the statement, bill or other notice.
- (d) The dispute resolution regime in this clause 11.2 provides procedures to resolve disputes between parties, not sanctions for *Code* breach. The dispute resolution processes may indicate that a *Code* breach has occurred and the resolution or determination of the dispute may take account of the damage thereby caused to a party. However any action for *Code* breach shall be taken by the *Commission* in accordance with clause 11.5 and the *Act*.
- (e) It is intended that the dispute resolution regime set out in or implemented in compliance with the *Code* and described in detail in this clause 11.2 should to the extent possible:
 - (1) be guided by the industry objectives and *Code* objectives;
 - (2) be simple, quick and inexpensive;
 - (3) preserve or enhance the relationship between the parties to the dispute;
 - (4) take account of the skills and knowledge that are required for the relevant procedure;
 - (5) observe the rules of natural justice;
 - (6) place emphasis on conflict avoidance; and
 - (7) encourage resolution of disputes without formal legal representation or reliance on legal procedures.
- (f) Subject to clause 11.2.1(g), where any dispute of a kind set out in clause 11.2.1(a) arises the parties concerned shall comply with the procedures set out in clauses 11.2.3 to 11.2.11 before taking any other action in relation to the dispute.
- (g) Clause 11.2.1(f) does not prevent a party seeking an urgent interlocutory injunction from a court of competent jurisdiction.

11.2.2 Code Participant's dispute management systems

Each *Code Participant* shall adopt and implement, a dispute management system ("DMS") which meets the criteria determined by the *Commission* following consultation with *Code Participants*.

11.2.3 First stage dispute resolution processes

Where any dispute of a kind set out in clause 11.2.1(a) arises, the parties concerned shall observe the following procedures before taking other action in relation to the dispute:

- (a) In the first instance, one of the parties concerned shall raise the dispute by giving written notice to the other party or parties.
- (b) Once a *Code Participant* has given notice as described in clause 11.2.3(a) the parties concerned shall act in good faith and use all reasonable endeavours to resolve the dispute through the procedures and alternative dispute resolution mechanisms applicable to the parties through their DMSs. If the procedures and alternative dispute resolution mechanisms applicable to the parties through their DMSs are inconsistent in any way and the parties are unable to resolve the inconsistency, any of the parties may request the *Commission* to determine which procedure and/or alternative dispute resolution mechanism is to prevail.

11.2.4 Second stage dispute resolution processes

- (a) If the dispute is not resolved through the first stage dispute resolution processes set out in clause 11.2.3 within:

- (1) in the case of disputes about trading, *power system* operation directions and *metering*, 5 *business days* after a notice under clause 11.2.3(a) (or such other period agreed in writing by each party to the dispute); or
- (2) in all other cases, 10 *business days* after a notice under clause 11.2.3(a) (or such other period agreed in writing by each party to the dispute),

a party (the "*complainant*") may, provided the *complainant* has, in good faith, followed the first stage dispute resolution processes set out in clause 11.2.3, refer the matter to the *Commission* who shall follow the procedure set out in this clause 11.2.4.

- (3) In referring the matter to the *Commission*, the *complainant* shall set out in writing a brief history of the dispute including:
 - (i) the names of the parties to the dispute;
 - (ii) the grounds of the dispute; and
 - (iii) the results of any previous dispute resolution processes undertaken pursuant to the *Code* in respect of the dispute.
- (b) Where a dispute has been referred to the *Commission* under clause 11.2.4(a), the *Commission*, before taking any action to resolve the dispute, shall be satisfied that the dispute is one to which clause 11.2 applies.
- (c) Any other party to the dispute may provide the *Commission* with his own short written history of the dispute or may comment thereon.
- (d) The *Commission* shall give notice to the *complainant* and the other parties to the dispute as to whether it is satisfied that the dispute is one to which clause 11.2 applies.
- (e) If the *Commission* is not satisfied that the dispute is one to which clause 11.2 applies, the procedures set out below in this clause 11.2 do not apply to the dispute.
- (f) If the *Commission* is satisfied that the dispute is one to which clause 11.2 applies, the *Commission* shall:

- (1) in the case of disputes about trading, *power system* operation directions and *metering*, immediately (or within such other period agreed in writing by each party to the dispute); or
 - (2) in all other cases, within 2 *business days* (or such other period agreed in writing by each party to the dispute), either:
 - (3) refer the dispute for resolution by a Dispute Resolution Panel (DRP) established under clause 11.2.5; or
 - (4) decide that the dispute should be resolved by the *Commission* in the form of dispute resolution laid down by the *Commission* following consideration of the guiding principles set out in clause 11.2.1.
- (g) The effect of a resolution of the dispute through that dispute resolution process will be as set out in clause 11.2.8.

11.2.5 Dispute Resolution Panels

- (a) The *Commission* shall identify and maintain a database of persons who are professionally trained in dispute resolution techniques and who are experts in various fields, from among whom the *Commission* may select suitable persons from time to time on such terms and conditions as the *Commission* may determine, to be members of *Dispute Resolution Panels* (DRPs).
- (b) Where the *Commission* refers a dispute for resolution by a DRP as contemplated in clause 11.2.4(f)(3), the *Commission* shall establish a three member DRP comprising three persons chosen by the *Commission* as suitable in the particular circumstances from the group of persons referred to in 11.2.5(a). The *Commission* shall consult with the parties to the dispute prior to the appointment of the persons to comprise the DRP. The *Commission* shall be satisfied that the persons so chosen:
 - (1) do not have any interests which could conflict with an impartial resolution of the dispute; and
 - (2) are experts in the field to which the dispute relates.
- (c) The *Commission* shall nominate one of the DRP members to be the chairperson.
- (d) Any person who has previously served on a DRP is eligible for reappointment to the DRP in accordance with this clause 11.2.5.
- (e) Following the reference of a matter to a DRP under clauses 11.2.4(f)(3), the DRP shall select the form of dispute resolution process which it considers appropriate in the circumstances.
- (f) The dispute resolution process will take place at such venue as may be required by the selected form of dispute resolution process or otherwise as determined by the DRP in consultation with the parties and may include either party's premises or any other premises.
- (g) The DRP may meet separately and/or jointly with the parties.
- (h) The DRP may require parties to exchange submissions, documents and information.
- (i) The DRP may consult anyone it sees fit and will consult all parties to the dispute and give them an adequate opportunity to present their case.
- (j) The DRP may mediate the dispute.
- (k) Subject to clause 11.2.5(l), the DRP shall ensure that the dispute resolution process selected is completed within 40 *business days* of the dispute being referred to the

DRP (or such longer period as the *Commission* may permit following a request by the DRP for an extension of time). Within 10 *business days* (or such other period determined by the DRP and notified to the parties in writing) of reaching a mediated solution or of notification by the DRP of the completion of the dispute resolution process (as the case requires), the parties shall report back to the DRP on actions taken pursuant to the mediated solution or any DRP determination.

- (l) In the case of disputes about trading, *power system* operation directions and *metering* disputes, the DRP shall ensure that the dispute resolution process selected is completed within 10 *business days* of referral of the dispute to the DRP (or such longer period as the *Commission* may permit following a request by the DRP for an extension of time). Within 5 *business days* (or such other period determined by the DRP and notified to the parties in writing) after reaching a mediated solution or of notification by the DRP of the completion of the dispute resolution process (as the case requires), the parties shall report back to the DRP on actions taken pursuant to the mediated solution or any DRP determination.

11.2.6 Legal representation

Legal representation before the DRP may only be permitted by the DRP when the DRP considers it necessary to do so to accord the parties natural justice or for such other reason as the DRP may consider appropriate in all the circumstances.

11.2.7 Cost of dispute resolution

- (a) Except as provided in clause 11.2.7(b), the costs of any dispute resolution processes (other than legal costs of one or more parties) including the costs charged by the *Commission* and any third party for facilitating the dispute resolution procedures, are to be borne equally by the parties to the dispute unless otherwise agreed between the parties as part of the dispute resolution process.
- (b) Costs of the dispute resolution (including legal costs of one or more parties) may be allocated by the DRP for payment by one or more parties as part of any determination.

11.2.8 Effect of resolution

- (a) A resolution of the dispute agreed between the parties to the dispute and, a determination of the DRP or a determination by the *Commission* pursued following a decision by the *Commission* under clause 11.2.4(f)(4), shall be binding on the parties to the dispute, including, without limitation, any provision of the resolution or determination relating to the payment of monies by any of the parties and any provision as to the performance of specific actions by any of the parties.
- (b) A requirement that a *Code Participant* pay monies imposed on the *Code Participant* under:
- (1) a determination of the DRP;
 - (2) a determination as a result of any other form of dispute resolution pursued following a decision by the *Commission* under clause 11.2.4(f)(4); or
 - (3) an agreement reached between the parties to a dispute under this dispute resolution process,

is an obligation under the *Code* to pay such amounts. A *Code Participant* entitled to such amount which is not paid within 28 *days* after it is due in accordance with the *Code*, may recover the amount summarily in a court of competent jurisdiction as a civil debt payable by the other *Code Participant*.

- (c) A *Code Participant* shall comply with a determination of the DRP or a determination of the *Commission* pursued following a decision by the *Commission* under clause 11.2.4(f)(4). Failure to do so is a breach of the *Code* and may be referred to the *Commission* as an alleged breach of the *Code* in accordance with the *Act*.

11.2.9 Recording and publication

- (a) Where a DRP resolves a dispute, details of the resolution of the dispute shall be recorded by the DRP and forwarded to the *Commission*.
- (b) The DRP or the *Commission* (as appropriate) shall produce a summary of their determinations or the results of mediation, without identifying the parties, and forward these to the *Commission* which shall publish this information on a regular basis or otherwise regularly make it available to all *Code Participants*.
- (c) Claims for confidentiality of information disclosed in the dispute resolution process shall be dealt with in accordance with the provisions for use of information in clause 11.7.3(b). Subject to the specific terms of that clause, the confidentiality provisions of clause 11.6 apply.

11.2.10 Appeals

Any party aggrieved by the resolution of a dispute by a DRP may appeal to the *Commission* and an appeal against the *Commission's* decision shall be to the High Court.

11.2.11 Limitation of Liability

To the extent permitted by law, the *Commission*, the DRP and its members, are not to be liable for any loss or damage suffered or incurred by a *Code Participant* or any other person as a consequence of any act or omission of those persons which was done in good faith.

11.2.12 Review by the Commission of dispute resolution procedures

- (a) The *Commission* shall undertake a review of the appropriateness of the dispute resolution procedures as set out in clause 11.2. This review shall be conducted in accordance with the *Code consultation procedures*.
- (b) The review carried out pursuant to clause 11.2.12(a) shall consider:
- (1) the efficacy of the dispute resolution procedures specified in clause 11.2;
 - (2) whether *Code Participants'* rights to issue notices of dispute under clause 11.2.3(a) should be limited to a prescribed time period after the factor circumstance proposed to be dealt with in the notice of dispute became known or occurred; and
 - (3) such other matters as the *Commission* considers appropriate.

11.3 CODE CHANGE

11.3.1 Code Change Panel

- (a) The *Commission* shall establish a *Code Change Panel* ("CCP"). The CCP shall consider matters referred to it by the *Commission* under this clause 11.3 including the examination of suggested *changes* to the *Code* or the identification of provisions in relation to which *changes* may be necessary or desirable and shall make recommendations to the *Commission* in relation to these matters.
- (b) The CCP is to consist of:

- (1) the Chairman, who will be nominated by the *Commission* from among its officers;
- (2) at least 3 but not more than 5 other persons appointed by the *Commission* for a period of up to three years to represent (without limitation):
 - (i) *Code Participants*;
 - (ii) professional associations (such as the Institution of Engineers of Kenya) and
 - (iii) *consumers*.
- (c) Any person who has previously served on the CCP is eligible for reappointment to the CCP in accordance with this clause 11.3.1.
- (d) A person shall cease to be a member of the CCP if:
 - (1) he is unable to perform the functions of his office by virtue of mental or physical infirmity;
 - (2) he is declared or becomes bankrupt;
 - (3) he is convicted of a criminal offence involving dishonesty, fraud or moral turpitude;
 - (4) he is absent from two consecutive meetings of the CCP without reasonable cause to the satisfaction of the CCP in consultation with the *Commission*;
 - (5) he dies;
 - (6) he resigns by giving notice in writing to this effect to the *Commission*;
 - (7) in the *Commission's* opinion the person ceases to be independent of any *Code Participant*;
 - (8) the person fails to discharge the obligations of that office imposed by the *Code*, or
 - (9) the *Commission* terminates his appointments for any or no reason.
- (e) Where a person ceases to be a member of the CCP, the *Commission* may appoint another person in his place.
- (f) The CCP may meet and regulate its meetings and conduct its business in any manner which does not conflict with the *Code*, but it shall meet not less than twice every year.
- (g) The CCP may obtain such advice or other assistance from time to time as it thinks appropriate including, without limitation, advice or assistance from persons with experience relevant to the *change* under consideration and from *Code Participants* who are likely to be affected by any such *change*.

11.3.2 How the Code may be changed

The provisions of the *Code* may only be changed, whether by a *change* of general application, transitional provision or otherwise:

- (a) when the CCP has recommended the *change* and the procedures set out in clauses 11.3.2 to 11.3.8 inclusive have been followed;
- (b) where the *change* is a transitional provision or an extension of a transitional provision and the procedures set out in clause 11.4 have been followed;
- (c) when the *System Planning and Reliability Council* has recommended the *change* and the procedures set out in clause 11.8.3 have been followed; or

- (d) where the *Commission* considers that the *change* is minor or procedural or is made to correct a manifest error and the procedures in clause 11.3.9 have been followed, and, in any case, provided the *Commission* agrees to the adoption and implementation of the *change* or the grant of the transitional provision or extension of the transitional provision (as the case may be).

11.3.3 Referral of matters to CCP

- (a) A *Code Participant* or any other person may make a written submission to the *Commission* to suggest a *change* to the *Code* or to identify any provision in relation to which the *Code Participant* or person considers that a *change* may be necessary or desirable. The submission shall include a brief statement of the reasons why a *change* is necessary or desirable.
- (b) Where a *Code Participant* or any other person has made a submission to the *Commission* as described in clause 11.3.3(a), the *Commission* shall within 10 *business days* determine whether the matter is one of general application or whether it should be dealt with as an application for a transitional provision under clause 11.4. In the latter case, the *Commission* shall deal with the matter under the provisions of clause 11.4. If the *Commission* is of the opinion that the matter is one of general application, it shall within 30 *days* after receiving the submission refer the matter to the CCP for its consideration and subsequent report to the *Commission*.
- (c) The *Commission* may at any time refer a proposed *change* to the *Code* to the CCP even without a submission from a *Code Participant* or any other person.
- (d) The *Commission* shall refer all proposed *changes* to the *Code* to the CCP for its consideration.

11.3.4 Consideration and recommendations by the CCP

- (a) Where a proposed *change* is referred to the CCP, the CCP shall consider the matter and report to the *Commission* with its recommendations in accordance with the terms of reference agreed to by the *Commission* and the CCP.
- (b) If the *Commission* refers a proposed *change* to the CCP, the CCP shall consider the proposed *change* and, within 10 *days* after the referral, give notice to the *Commission* and the *Code Participant* or any other person who has made the relevant submission under clause 11.3.3 as to whether the proposed *change* is, in the CCP's opinion:
 - (1) of such a nature that further consideration is warranted; or
 - (2) of such a nature that no further consideration is warranted.
- (c) If the CCP is required to further consider the proposed change, because it is of the view that such proposed change warrants further consideration, the CCP shall comply with the following process:
 - (1) a notice shall be given to all *Code Participants* and interested parties giving particulars of the proposed change. The notice shall invite interested *Code Participants* and interested parties to make written submissions to the CCP concerning the proposal;
 - (2) to be valid, a submission shall be received not later than 30 *days* (or such longer period as may be agreed to by the *Commission* and the CCP and stated in the notice) after the notice referred to in clause 11.3.4(c)(1) is given;

- (3) the CCP shall consider all valid submissions within a further 30 *days* (or such longer period as may be agreed to by the *Commission* and the CCP);
- (4) before agreeing to a longer period as provided for in clause 11.3.4(c)(2) or clause 11.3.4(c)(3), the *Commission* and the CCP should consider:
 - (i) the *Code* objective stated in clause 1.4(e), namely, to provide efficient processes for changing the *Code*;
 - (ii) the public interest;
 - (iii) ensuring that *Code Participants* and interested parties are given sufficient opportunity to participate effectively in consultation on proposed *changes* to the *Code*; and
 - (iv) the CCP having sufficient opportunity to consider proposed *changes* to the *Code* and submissions received through consultation on proposed *changes* to the *Code*.
- (5) before making a recommendation in relation to a proposed change, the CCP shall prepare a draft recommendation in relation to the proposed change, including a summary of the submissions received and details of the CCP's reasons for arriving at the draft recommendation;
- (6) the CCP shall forward to each *Code Participant* and interested party a copy of the draft recommendation together with a written notice inviting that person to make a submission in relation to the draft within 21 *days* after the date of the invitation. A submission may include a request that the CCP hold a meeting in relation to the draft recommendation;
- (7) if each of the persons to whom an invitation was sent under clause 11.3.4(c)(6):
 - (i) notifies the CCP within the 21 *day* period referred to in that clause that it does not wish the CCP to hold a meeting in relation to the draft recommendation; or
 - (ii) does not notify the CCP within that period that it wishes the CCP to hold such a meeting;the CCP may make the recommendation at any time after the expiration of that period;
- (8) if any of the persons to whom a notice has been given under clause 11.3.4(c)(6) makes, within the 21 *day* period mentioned in that clause, a submission to the CCP, including notice that he wishes the CCP to hold a meeting in relation to the draft recommendation, the CCP shall appoint a date (being not later than 21 *days* after the expiration of that period), time and place for the holding of the meeting and give notice of the date, time and place so appointed to each of the persons to whom a notice was sent under clause 11.3.4(c)(6);
- (9) the CCP shall take account of all matters raised at the meeting and may at any time after the termination of the meeting make a recommendation in respect of the proposed change;
- (10) following the conclusion of its consideration of a matter referred to it by the *Commission*, the CCP shall submit a written report to the *Commission* setting out the recommendations of the CCP, its reasons for those recommendations and the procedure followed by the CCP in considering the matter.
- (11) If the *Commission* so requests the CCP, the CCP shall give to the *Commission* copies of all valid submissions by *Code Participants* and interested parties

together with particulars of any further matters which were placed before the CCP during the course of any meetings that may have been held with *Code Participants* or interested parties.

- (d) In formulating any recommendations, the CCP shall take into consideration the industry objectives and the *Code* objectives.

11.3.5 Consideration of CCP recommendations by the Commission

- (a) The *Commission* shall, within 14 *days* of receiving the CCP's report, give written notice of the CCP's recommendation to all other *Code Participants* and interested parties and, subject to the provisions of clause 11.6, make available to all other *Code Participants* and interested parties on request, copies of any material submitted to the CCP or the *Commission*.
- (b) Any *Code Participant* or interested party may, within 14 *days* of the date of the notice given under clause 11.3.5(a), give written notice to the *Commission* that the *Code Participant* or interested party objects to the CCP's recommendation.
- (c) The *Commission* shall consider each report from the CCP together with any objections under clause 11.3.5(a) in deciding whether or not to reject or favour the adoption and implementation of all or any of the recommendations contained in that report.
- (d) In considering any recommendation concerning a proposed *Code* change from the CCP, the *Commission* shall determine if the proposed change is consistent with the *Code* objectives and may only reject a *Code* change recommended by the CCP if it considers the change would be inconsistent with the *Code* objectives.
- (e) The *Commission* shall notify all *Code Participants* and interested parties of the CCP's recommendations, its decisions concerning those recommendations and, if the *Commission* decides to reject some or all of the CCP's recommendations, the *Commission's* reasons for that decision. Particulars of the *Commission's* decisions and, if relevant, its reasons for rejecting any of the CCP's recommendations shall also be provided to the CCP.

11.3.6 Adoption and implementation

- (a) the *Commission* may adopt and implement the change by notice of the change being published in the Kenya Gazette. The change will take effect on the later of:
- (1) the date of publication of the notice of approval and of the change in the Kenya Gazette; and
 - (2) the date specified in the notice for the commencement of the change.

11.3.7 “Fast-track procedures”

- (a) If the *Commission* considers that it is necessary or desirable to change the *Code* in relation to any matter (including any matter which may be referred to the *Commission* by a *Code Participant* or interested party) which is:
- (1) of a minor or procedural nature; or
 - (2) required to correct a manifest error.

the *Commission* shall hold consultations or ask for submissions from only such *Code Participants* and interested parties as the *Commission* considers appropriate. After holding any such consultations or receiving any such submissions the *Commission* shall notify all *Code Participants* and interested parties of the proposed change. *Code Participants* and interested parties may object in writing to the

proposed change within 7 days (or such longer period as may be allowed in the notice) after the *Commission's* notice is published.

- (b) The *Commission* shall consider any timely objections received by it following the publication of the notice referred to in clause 11.3.9(a). After giving due consideration to any such objections if the *Commission* decides to proceed with the proposed change, it shall comply with clauses 11.3.6 to 11.3.8 where references to the CCP recommendations are taken to be references to the proposed change.

11.3.8 Notice by publication

- (a) In addition to the provisions of clause 1.8, a notice is properly given by the *Commission* to a person under clause 11.3 or 11.4 if a copy of the notice is published in a daily newspaper circulated generally.
- (b) A notice given under this clause 11.3.10 is treated as being given to a person by the *Commission* on the date when the notice is published in a newspaper referred to in clause 11.3.8(a).

11.3.9 CCP indemnity

Neither the CCP nor any of its members from time to time are to be liable in any way for any change made to the *Code* whether under this clause 11.3 or otherwise.

11.4 TRANSITIONAL PROVISIONS

11.4.1 Meaning of transitional provisions

- (a) Subject to clause 11.3.2, the *Commission* may, on application of any *Code Participant*, decide that any one or more of the provisions of the *Code* which would otherwise apply in relation to that *Code Participant*, either generally or in a particular case or class of cases:
 - (1) does not apply to that *Code Participant* in those circumstances; or
 - (2) applies as specially modified or varied, (a “transitional provision”).
- (b) This clause 11.4 does not relate to or affect any transitional provision made under Chapter 12 of the *Code* unless specifically provided in Chapter 12.
- (c) A *Code Participant* may by notice to the *Commission* request an extension of the period for which a transitional provision has been granted.
- (d) Where the *Commission* receives a submission from a *Code Participant* under clause 11.3.3(a) which in the *Commission's* opinion should be deemed to be an application from that *Code Participant* for a transitional provision, the *Commission* shall give notice to that *Code Participant* that the *Commission* has formed such opinion. The submission shall then be dealt with under the provisions of this clause 11.4.

11.4.2 When the Commission may grant a transitional provision or extend a transitional provision

The *Commission* shall not grant a transitional provision or an extension of a transitional provision unless it has approved the transitional provision or extension and unless:

- (a) the *Commission* has given notice to all *Code Participants* and interested parties of the application or deemed application for the transitional provision or for the extension. The notice shall set out details of any opportunities which *Code Participants* and interested parties will be given to make any submissions in relation to the proposed transitional provision or extension in question;

- (b) the *Commission* has afforded *Code Participants* and interested parties the opportunities described in the notice to make any submissions in relation to the transitional provision or extension in question; and
- (c) the *Commission* has taken into consideration any submissions which it has received.

11.4.3 Decisions by the Commission regarding proposed transitional provisions

- (a) In deciding whether or not to grant the transitional provision or extension, the *Commission* may seek the advice of the CCP. If the *Commission* seeks advice it shall consider the advice which it receives from the CCP.
- (b) The *Commission* shall inform the *Code Participant* who applied for or is deemed to have applied for the transitional provision or extension of the *Commission's* decision. Such decision may be:
 - (1) to grant the transitional provision or extension, either as requested or having the effect requested;
 - (2) to make the grant in question subject to conditions; or
 - (3) to refuse to grant the transitional provision or extension.
- (c) Without limitation, the *Commission* shall not grant a transitional provision or an extension of a transitional provision for an unspecified period of time.
- (d) The *Commission* shall advise its members prior to making any decision in terms of clause 11.4.3(b)(1) or (2).

11.4.6 Notice by publication

The provisions of clause 11.3.8 also apply to clause 11.4.

11.5 ENFORCEMENT

11.5.1 Investigations

- (a) A *Code Participant* shall, if requested by the *Commission*, supply it with information relating to any matter concerning the *Code* in such form, covering such matters and within such reasonable time as the *Commission* may request.
- (b) If a *Code Participant* fails to comply with a request by the *Commission* for information as described in clause 11.5.1(a), the *Commission* may appoint a person to investigate the matter and to prepare a report or such other documentation as the *Commission* may require. A *Code Participant* shall assist the person to undertake the investigation and to prepare the report or other documentation. In addition, a *Code Participant* shall, at the request of the person appointed, direct third parties to make available such information as the person may reasonably require.
- (c) The cost of the investigation and of preparing the report or other documentation prepared by the person appointed shall be met by the *Code Participant* directed to supply the information under clause 11.5.1(a) unless the *Commission* otherwise determines.
- (d) Any report or other documentation referred to in this clause 11.5.1 may be used in any proceeding involving the *Commission* under the *Act* or for the purpose of commencing any such proceeding.
- (e) The *Commission* shall develop and implement guidelines in accordance with the *Code consultation procedures* governing the exercise of the powers conferred on it by this clause 11.5.1.
- (f) The guidelines referred to in clause 11.5.1(e) shall set out the circumstances which a *Code Participant* will be required to bear the cost of providing the information sought by the *Commission* under this clause 11.5.1, including where no breach of the *Code* by the relevant *Code Participant* has occurred.

11.5.2 Right of entry and inspection

The *Commission* and its authorised officers and representatives shall have such rights of entry to premises and installations as may be granted under the *Act*.

11.5.3 The functions of the Commission

The functions of the *Commission* are set out in the *Act*.

11.5.4 Procedures concerning alleged breaches of the Code

- (a) If a *Code Participant* considers that another *Code Participant* or *consumer* may have breached or may be breaching this *Code* or any provision in their *connection agreement*, the aggrieved *Code Participant* may, in accordance with this *Code* or the terms of their *connection agreement*:
- (1) give notice to the person in breach to immediately take steps to remedy and/or stop the breach, as the case may be;
 - (2) subject to clause 11.5.5, impose any sanctions on the person in breach as provided in this *Code* or their *connection agreement* and
 - (3) the without limitation to his powers, use reasonable endeavours to give effect to any sanctions so imposed.
- (b) If the *Commission* considers that:
- (1) a *Code Participant* may have breached or may be breaching the *Code*; and
 - (2) in the circumstances and if the breach is established, it would be appropriate that a sanction or sanctions be imposed on that *Code Participant*,
- the *Commission* shall notify the *Code Participant* of the alleged breach and details of the sanctions which may be imposed if the breach is established.
- (c) If the *Commission* receives written information from a *Code Participant* or any other person which alleges a breach of the *Code* by a *Code Participant*, the *Commission* shall within 5 *business days* of receipt of the information determine whether, based on that information, there would appear *prima facie* to be a breach of the *Code*.
- (d) If the *Commission* considers that a *Code Participant* may be the subject of a *disconnection* order it shall:
- (1) promptly notify the *Code Participants* which the *Commission* considers may be affected; and
 - (2) without limitation to its powers, use reasonable endeavours to give effect to any arrangements notified to the *Commission* by the *Code Participants* for ensuring the continuation of *supply* to the relevant purchasers of electricity.

11.5.5 Sanctions

The nature of sanctions which may be imposed under the *Code* and the circumstances in which a *Code Participant* or the *Commission* may implement any sanction which has been imposed, shall be set out in regulations approved or issued by the *Commission*.

11.5.6 Action by the Commission to give effect to its orders

- (a) The *Commission* may direct a *Code Participant* or any person to do or refrain from doing anything which the *Commission* thinks necessary or desirable to give effect or assist in giving effect to any of its orders.
- (b) Without limiting the generality of clause 11.5.6(a), the *Commission* may direct a *network service provider* to *disconnect* a *Code Participant* or any *consumer* from

any *transmission system* or *distribution system* in order to assist in giving effect to any of its orders.

- (c) A *Code Participant*, *consumer* or any person shall comply with a direction given under clause 11.5.6(a).

11.5.7 Actions by agents, employees or officers of Code Participants

If any partner, *agent*, officer or employee of a *Code Participant* does any act or refrains from doing any act which if done or not done (as the case may be) by a *Code Participant* would constitute a breach of the *Code*, such act or omission shall be deemed for the purposes of this clause 11.5 to be the act or omission of the *Code Participant* concerned.

11.5.8 Publication

- (a) The *Commission* shall publish a report at least once every six months setting out a summary for the period covered by the report of:
- (1) matters which have been referred to it;
 - (2) all its findings during that period; and
 - (3) any sanctions it applied under the *Act*.
- (b) In considering the circulation of a report under clause 11.5.8(a), the *Commission* shall have regard to the industry objectives and the *Code* objectives set out in Chapter 1.
- (c) In addition to the regular publication described in clause 11.5.8(a), the *Commission* may publish a report on any one or more matters which have been referred to it, its findings in relation to those matters and any sanctions imposed in relation to those matters. A decision by the *Commission* to publish a report under clause 11.5.8(c) is a reviewable decision.
- (d) No *Code Participant*, or former *Code Participant* is entitled to make any claim against the *Commission* for any loss or damage incurred by the *Code Participant* or former *Code Participant* from the publication of any information pursuant to clause 11.5.8(a) or (c) if the publication was done in good faith. No action or other proceeding will be maintainable by the person or *Code Participant* referred to in the publication against the *Commission* or any person publishing or circulating the publication on behalf of the *Commission* and this clause operates as leave for any such publication except where the publication was not done in good faith.
- (e) Claims for confidentiality of information which may be published under clause 11.5.8 (a) or (c) shall be dealt with in accordance with the provisions for reporting of information in clause 11.7.3(b). Subject to the specific terms of that clause, the confidentiality provisions of clause 11.6 apply.
- (f) The *Commission* shall, and is entitled to, provide the reports referred to in clause 11.5.8(a) and (c) to all *Code Participants* and interested parties. However, the *Commission* is not required to provide a report to such a person if the *Commission* considers it is inappropriate in the circumstances, including without limitation, where there may be confidentiality issues.

11.5.9 System security directions

- (a) Notwithstanding any other provisions of the *Code*, a *Code Participant* shall follow any direction issued by or on behalf of the *System Operator* which the *System Operator* is entitled to issue in exercising his powers under Chapter 7 of the *Code* relevant to maintaining or restoring *power system security*.

- (b) Any event or action required to be performed pursuant to a direction issued under Chapter 7 of the *Code* on or by a stipulated *day* is required by the *Code* to occur on or by that *day*, whether or not a *business day*.
- (c) Any failure to observe such a direction will be deemed to be a breach of the *Code*.
- (d) Any *Code Participant* who is aware of any such failure or who believes any such failure has taken place shall refer the allegation to the *Commission* in accordance with the procedures contained in this clause 11.5.

11.6 CONFIDENTIALITY

11.6.1 Confidentiality

- (a) Each *Code Participant* shall use all reasonable endeavours to keep confidential any *confidential information* which comes into the possession or control of that *Code Participant* or of which the *Code Participant* becomes aware.
- (b) A *Code Participant*:
 - (1) shall not disclose *confidential information* to any person except as permitted by the *Code*;
 - (2) shall only use or reproduce *confidential information* for the purpose for which it was disclosed or another purpose contemplated by the *Code*;
 - (3) shall not permit unauthorised persons to have access to *confidential information*.
- (c) Each *Code Participant* shall use all reasonable endeavours:
 - (1) to prevent unauthorised access to *confidential information* which is in the possession or control of that *Code Participant*; and
 - (2) to ensure that any person to whom he discloses *confidential information* observes the provisions of this clause 11.6 in relation to that information.
- (d) The officers of the *transmission network service provider* participating in *transmission service* pricing shall not be involved in or associated with competitive electricity trading activities of any other *Code Participant*.
- (e) The *transmission network service provider* participating in *transmission service* pricing shall provide to any *transmission network service provider* or *Code Participant* who supplies information for *transmission service* pricing an undertaking that the *transmission network service provider* to which that information was supplied will comply with the confidentiality requirements set out in this clause 11.6.

11.6.2 Exceptions

This clause 11.6 does not prevent:

- (a) the disclosure, use or reproduction of information if the relevant information is at the time generally and publicly available other than as a result of breach of confidence by the *Code Participant* who wishes to disclose, use or reproduce the information or any person to whom the *Code Participant* has disclosed the information;
- (b) the disclosure of information by a *Code Participant* or the *Code Participant's discloses* to:
 - (1) an *agent* of the *Code Participant* or a related body corporate of the *Code Participant*; or
 - (2) a legal or other professional adviser, auditor or other consultant (in this clause called "Consultants") of the *Code Participant*, which require the information

- for the purposes of the *Code*, or for the purpose of advising the *Code Participant* or the *Code Participant's disclosee* in relation thereto;
- (c) the disclosure, use or reproduction of information with the consent of the person or persons who provided the relevant information under the *Code*;
 - (d) the disclosure, use or reproduction of information to the extent required by law or by a lawful requirement of:
 - (1) any government or governmental body, authority or agency having jurisdiction over a *Code Participant* or his related bodies corporate; or
 - (2) any stock exchange having jurisdiction over a *Code Participant* or his related bodies corporate;
 - (e) the disclosure, use or reproduction of information if required in connection with legal proceedings, arbitration, expert determination or other dispute resolution mechanism relating to the *Code*, or for the purpose of advising a person in relation thereto;
 - (f) the disclosure, use or reproduction of information which is trivial in nature;
 - (g) the disclosure of information if required to protect the safety of personnel or equipment;
 - (h) the disclosure, use or reproduction of information by or on behalf of a *Code Participant* to the extent reasonably required in connection with the *Code Participant's* financing arrangements, investment in that *Code Participant* or a disposal of that *Code Participant's assets*;
 - (i) the disclosure of information to the *Commission*, or any other Regulatory authority having jurisdiction over a *Code Participant*, pursuant to the *Code* or otherwise;
 - (j) the disclosure, use or reproduction of information of an historical nature in connection with the preparation and giving of reports under the *Code*; or
 - (k) the disclosure, use or reproduction of information as an unidentifiable component of an aggregate sum.

11.6.3 Conditions

In the case of a disclosure under clause 11.6.2(b) or 11.6.2(h) prior to making the disclosure the *Code Participant* who wishes to make the disclosure shall inform the proposed recipient of the confidentiality of the information and shall take appropriate precautions to ensure that the recipient keeps the information confidential in accordance with the provisions of this clause 11.6 and does not use the information for any purpose other than that permitted under clause 11.6.1.

11.6.4 Application of confidentiality provisions to the Commission

For the purpose of clause 11.6 (other than clause 11.6.5), "*Code Participant*" includes the *Commission* and any council, panel or other body established by the *Commission* under the *Code*.

11.6.5 Indemnity to the Commission

Each *Code Participant* indemnifies the *Commission* against any claim, action, damage, loss, liability, expense or outgoing which the *Commission* pays, suffers, incurs or is liable for in respect of any breach by that *Code Participant* or any officer, *agent* or employee of that *Code Participant* of this clause 11.6 of the *Code*.

11.6.6 Code Participant information

Each *Code Participant* shall develop and, to the extent practicable, implement a policy:

- (a) to protect information which he acquires pursuant to his various functions from use or access which is contrary to the provisions of the *Code*;
- (b) to disseminate such information in accordance with his rights, powers and obligations in a manner which promotes the orderly operations of the industry; and
- (c) to ensure that the *Code Participant* in undertaking any activity under the *Code* does not make use of such information unless the information is also available to other *Code Participants*.

11.6.7 Information on Code bodies

The *Commission* shall develop and implement policies concerning:

- (a) the protection of information which *Code bodies* acquire pursuant to their various functions from use or access by *Code Participants* or *Code bodies* which is contrary to the provisions of the *Code*; and
- (b) the dissemination of such information where appropriate to *Code Participants* and interested parties.

11.7 MONITORING AND REPORTING

11.7.1 Monitoring objectives

- (a) The *Commission* is responsible for monitoring compliance with and shall use its reasonable endeavours to ensure the effectiveness of the *Code* in accordance with its objectives.
- (b) The *Commission* shall undertake such monitoring as it considers necessary:
 - (1) to determine whether *Code Participants* are complying with the *Code*;
 - (2) to assess whether the dispute resolution, *Code* enforcement, *Code* change and other mechanisms are working effectively in the manner intended;
 - (3) to determine whether in its operation, the *Code* is adequately giving effect to the *Code* objectives specified in clause 1.4; and
 - (4) to collect, analyse and disseminate information relevant and sufficient to enable the *Commission* to comply with its reporting and other obligations and powers under the *Code*.
- (c) The *Commission* shall ensure that, to the extent practicable in light of the objectives set out in clause 11.7.1(b), the monitoring processes which it implements under this clause 11.7:
 - (1) are consistent over time;
 - (2) do not discriminate unnecessarily between *Code Participants*;
 - (3) are cost effective to both the *Commission* and all *Code Participants*; and
 - (4) are publicised or information relating thereto is available to any person, subject to any requirements as a result of the confidentiality obligations in clause 11.6.

11.7.2 Code Participants' reporting requirements and monitoring standards

- (a) The *Commission* shall establish:
 - (1) reporting requirements for *Code Participants* in relation to matters relevant to the *Code*; and

- (2) procedures and standards applicable to the *Commission* and *Code Participants* relating to information and data received by or from *Code Participants* in relation to matters relevant to the *Code*.
- (b) Prior to establishing requirements or standards and procedures referred to in clause 11.7.2(a), the *Commission* shall consult with such *Code Participants* as the *Commission* considers appropriate. In formulating requirements or procedures and standards, the *Commission* shall take into consideration the monitoring objectives set out in clause 11.7.1. The reporting requirements and standards and procedures established by the *Commission* are reviewable decisions.
- (c) Subject to clause 11.7.2(d), the *Commission* shall notify to all *Code Participants* particulars of the requirements and procedures and standards which it establishes under this clause 11.7.2.
- (d) If the *Commission* establishes additional or more onerous requirements or procedures and standards which do not apply to all *Code Participants* and the *Commission* considers that notification of those matters to all *Code Participants* would contravene the confidentiality provisions in clause 11.6, the *Commission* may choose to notify only those *Code Participants* to whom the requirements or procedures and standards apply.
- (e) Each *Code Participant* shall comply with all requirements, procedures and standards established by the *Commission* under this clause 11.7 to the extent that they are applicable to him within the time period specified for the requirement, procedure or standard or, if no such time period is specified, within a reasonable time. Each *Code Participant* shall bear his own costs associated with complying with these requirements, procedures and standards.
- (f) In complying with his obligations or pursuing his rights under the *Code*, a *Code Participant* shall not recklessly or knowingly provide, or permit any other person to provide on behalf of that *Code Participant*, misleading or deceptive data or information to any other *Code Participant* or to the *Commission*.
- (g) Any *Code Participant* may ask the *Commission* to impose additional requirements, procedures or standards under this clause 11.7 on another *Code Participant* in order to monitor or assess compliance with the *Code* by that *Code Participant*. When such a request is made, the *Commission* may but is not required to impose the additional requirements, procedures or standards. A decision by the *Commission* to impose additional requirement procedures or standards is a reviewable decision. If the *Commission* decides to impose additional requirements, procedures or standards, the *Commission* may determine the allocation of costs of any additional compliance monitoring undertaken between the relevant *Code Participants*. *Code Participants* shall pay such costs as allocated. In the absence of such allocation, the *Code Participant* subject to the additional requirements, procedures or standards will bear his own costs of compliance.
- (h) The *Commission* shall develop and implement guidelines in accordance with the *Code consultation procedures* governing the exercise of the powers conferred on it by clause 11.7.2(g) which guidelines shall set out the matters to which the *Commission* shall have regard prior to deciding the allocation of costs of any additional requirements, procedures or standards imposed pursuant to clause 11.7.2(g) between the relevant *Code Participants*.

11.7.3 Use of information

- (a) Subject to the confidentiality obligations set out in clause 11.6, the *Commission* is entitled to use any data or information obtained as a result of any monitoring requirements imposed under clause 11.7.2 in pursuance of any of the *Commission's* powers or functions under the *Code*. Without limitation, the *Commission* may use any such information in connection with or to initiate:
- (1) a process to change the *Code* set out in clause 11.3; or
 - (2) an investigation under clause 11.5.
- (b) A *Code Participant* may claim that the information provided to the *Commission* is confidential in nature to the *Code Participant* or that the *Code Participant* is under an obligation to another person to maintain the confidentiality of all or part of the information. Notwithstanding that the *Commission* may consider the claim by the *Code Participant* to be reasonable, if the *Commission* considers that its reporting obligations set out in clause 11.5.8 or 11.7.4 make the disclosure of the information necessary or desirable, the *Commission* may disclose the information. In doing so, the *Commission* shall use all reasonable endeavours to ensure the information is disclosed only in a manner and to the extent which, as far as practicable, protects the confidential nature of the information and in no way is the *Commission* to be liable for publishing or disclosing any information under this clause 11.7.
- (c) Prior to disclosing in accordance with clause 11.7.3(b) information which a *Code Participant* claims is confidential, the *Commission* shall first notify that *Code Participant* as soon as practicable after the *Commission* has made the decision to disclose the information.
- (d) Any decision by the *Commission* under clause 11.7.3(b) to disclose information which is claimed by a *Code Participant* to be confidential is a reviewable decision, and the *Commission* shall not disclose the information until 28 *days* after it has provided written notice to the relevant *Code Participant* that it intends to disclose the information.

11.7.4 Reporting

- (a) Not later than 31 December in each calendar year, the *Commission* shall prepare and give an annual report for the previous *financial year* to all *Code Participants* and interested parties. The annual report shall include:
- (1) the *Commission's* assessment of the extent to which the operation of the *Code* during that period met the *Code* objectives and of the strategic development of the *Code* to meet industry objectives;
 - (2) the *Commission's* audited accounts for the period covered by the report;
 - (3) a report on the matters set out in clause 7.8.10(d) concerning the *System Operator's* use of powers of direction in relation to *power system security* granted to him under clause 7.8.10(a);
 - (4) a report detailing the use by *Code Participants* of inspection and testing rights conferred by clauses 3.7.1 and 3.7.2 during the period covered by the report;
 - (5) a summary of, and reasons for, any *changes* to the *Code* and of any *changes* recommended by CCP but not implemented;
 - (6) a summary of identified material breaches of the *Code* and the actions taken in response, including particulars of any sanctions imposed;
 - (7) a summary of any disputes involving the *Commission* and their resolutions;

- (8) a summary of material matters in relation to the dispute resolution regime set out in clause 11.2 (without identifying the parties); and
 - (9) the *Commission*'s assessment of the matters set out in clause 11.7.1(b) which it is required to monitor.
- (b) In addition to the annual report described in clause 11.7.4(a), the *Commission* may, if it considers it appropriate, provide an interim report to *Code Participants* and interested parties on any one or more of the matters which should be contained in the annual report.

11.7.6 Recovery of reporting costs

Where, under the *Code*, the *Commission* is entitled or required to publish or give information, notices or reports to any *Code Participant* or any other person, unless the context otherwise requires, the *Commission* (as the case may be) shall charge those persons a fee at cost for providing them with a copy of the information or report.

11.8 SYSTEM PLANNING AND RELIABILITY COUNCIL

11.8.1 Purpose of the System Planning and Reliability Council

- (a) The *Commission* shall establish a *System Planning and Reliability Council* as soon as practicable. The functions of the *System Planning and Reliability Council* will be to:
- (1) monitor, review and report on the performance of the industry in terms of reliability of the *power system*;
 - (2) determine, on the advice of the *System Operator*, the *power system security and reliability standards* and review the said standards as appropriate;
 - (3) while the *System Operator* has power to issue directions in connection with maintaining or re-establishing the *power system* in a reliable operating state, determine guidelines governing the exercise of that power;
 - (4) review the economic cost effectiveness analysis of proposed *network reinforcement* and other capital expenditure projects submitted by the *network service provider*, and in undertaking a review the *System Planning and Reliability Council* shall:
 - (i) assess whether the proposed option satisfies the regulatory test; and
 - (ii) make recommendations to the *Commission* on the options available to overcome a *network* constraint or inadequacy (including *generation* and *demand-side* options);
 - (5) report to the *Commission* on overall *power system* reliability matters concerning the *power system* and determinations of the matters described in clause 11.8.1(a)(2) and (3) and make recommendations to the *Commission* on *changes* to the *Code* and any other matters which the *System Planning and Reliability Council* considers necessary; and
 - (6) oversee, in consultation with the *System Operator*, the authorisation of persons to carry out switching and other operations on the *power systems* of the various *Code Participants*.
- (b) In performing its functions set out in clause 11.8.1(a) the *System Planning and Reliability Council* shall take into consideration any guideline published by the *Commission* from time to time.

- (c) Guidelines published by the *Commission* which are relevant to the responsibilities of the *System Planning and Reliability Council* as set out in clause 11.8.1(b) shall be developed by the *Commission* in consultation with affected *Code Participants* and other interested parties.

11.8.2 Constitution of the System Planning and Reliability Council

- (a) The *System Planning and Reliability Council* is to consist of:
 - (1) the Chairman, who will be nominated by the *Commission* from among its officers;
 - (2) the chief executive officer or a representative of the *System Operator*; and
 - (3) at least 3 but not more than 5 other persons appointed by the *Commission* for a period of up to three years.
- (b) Subject to clause 11.8.2(d) any person who has previously served on the *System Planning and Reliability Council* is eligible for reappointment to the *System Planning and Reliability Council* in accordance with this clause 11.8.2.
- (c) In making appointments to the *System Planning and Reliability Council* under clause 11.8.2(a)(3), the *Commission* shall, to the extent reasonably practicable, give effect to the intention that the persons so appointed:
 - (1) should be broadly representative, both geographically and by reference to *Code Participants*, of those persons with direct interests in reliability of electricity supply under the industry arrangements; and
 - (2) may include *Code Participants* or their representatives, and if at any time a person on the *System Planning and Reliability Council*, other than the chief executive officer or a delegate of the *System Operator*, ceases to be independent of the *System Operator*, the *Commission* shall remove that person from the *System Planning and Reliability Council*.
- (d) The *Commission* may remove any member of the *System Planning and Reliability Council*, including the Chairman, at any time during his or her term in the following circumstances:
 - (1) the person becomes insolvent or under administration;
 - (2) the person becomes of unsound mind or his or her estate is liable to be dealt with in any way under a law relating to mental health;
 - (3) the person resigns or dies;
 - (4) the person, other than the person appointed under clause 11.8.2(a)(2), ceases to be independent of the *Commission* and all *Code Participants*; or
 - (5) the person fails to discharge the obligations of that office imposed by the *Code*.
- (e) A person may resign from the *System Planning and Reliability Council* by giving notice in writing to that effect to the *Commission*.
- (f) The *System Planning and Reliability Council* shall meet and regulate its meetings and conduct its business in accordance with the *Code*.

11.8.3 Reliability review process

- (a) As soon as practicable, the *System Planning and Reliability Council* shall determine:
 - (1) the *power system security and reliability standards*; and

- (2) the guidelines referred to in clause 11.8.1(a)(3), in accordance with this clause 11.8.3.
- (b) At least once each calendar year and at such other times as the *Commission* may request, the *System Planning and Reliability Council* shall conduct a review of the reliability of the *power system*, the *power system security and reliability standards* and the guidelines referred to in clause 11.8.1(a)(3) in accordance with this clause 11.8.3.
- (c) The *Commission* shall advise the *System Planning and Reliability Council* of the terms of reference of any determination or review by the *System Planning and Reliability Council*. The *Commission* may advise the *System Planning and Reliability Council* of standing terms of reference in relation to the annual reviews described in clause 11.8.3(b) from time to time.
- (d) The *System Planning and Reliability Council* shall give notice to all *Code Participants* of a determination or review. The notice shall give particulars of the terms of reference for the determination or review (as the case may be), the deadline for the receipt of any submissions to the *System Planning and Reliability Council* and the date and place for the hearing referred to in clause 11.8.3(f). The notice shall be given at least 8 weeks prior to the hearing or such other time specified by the *Commission* in its request for the determination or review.
- (e) The deadline for receipt of submissions shall not be earlier than 4 weeks prior to the hearing or such other time specified by the *Commission* in its request for the determination or review.
- (f) The *System Planning and Reliability Council* shall hold a meeting open to all *Code Participants*.
- (g) The meeting referred to in clause 11.8.3(f) may be held in any location in Kenya deemed convenient and appropriate by the *System Planning and Reliability Council*.
- (h) The *System Planning and Reliability Council* may obtain such technical advice or assistance from time to time as it thinks appropriate including, without limitation, advice or assistance from the *System Operator* and any other *Code Participant*.
- (i) In undertaking any review and preparing any report and recommendations, the *System Planning and Reliability Council* shall take into consideration the policy statements, directions or guidelines published by the *Commission* from time to time.
- (j) Following the conclusion of the meeting and consideration by the *System Planning and Reliability Council* of any submissions or comments made to it, the *System Planning and Reliability Council* shall submit a written report to the *Commission* on the review setting out its recommendations or determinations, its reasons for those recommendations or determinations and the procedure followed by the *System Planning and Reliability Council* in undertaking the review or determination. The report shall be submitted to the *Commission* no later than 6 weeks after the hearing referred to in clause 11.8.3(f) or such other deadline for reporting specified by the *Commission* in its request for the review.
- (k) The *Commission* shall, within 10 days of receiving the written report of the *System Planning and Reliability Council*, make the report publicly available, subject to the confidentiality provisions of clause 11.6.
- (l) The recommendations of the *System Planning and Reliability Council* may include (without limitation) recommended *changes* to the *Code* in relation to matters concerning reliability of the *power system*.

- (m) A report by the *System Planning and Reliability Council* which includes a recommended change to the *Code* in relation to matters concerning reliability of the *power system* shall be treated by the *Commission* in the same manner as a report from the CCP. Accordingly, the provisions of clauses 11.3.4 to 11.3.8 will apply in these circumstances provided that references to the CCP will be taken to be references to the *System Planning and Reliability Council* and references to the procedures under clause 11.3 will be taken to be references to procedures under this clause 11.8.3.

11.9 CODE CONSULTATION PROCEDURES

- (a) These provisions apply wherever in the *Code* any person (“the *consulting party*”) is required to comply with the *Code consultation procedures*:
- (1) The *consulting party* shall give a notice to all persons nominated by the relevant provision as those with whom consultation is required, or if no persons are specifically nominated all *Code Participants* (“consulted persons”), giving particulars of the matter under consultation.
 - (2) The notice shall invite interested consulted persons to make written submissions to the *consulting party* concerning the matter.
 - (3) A written submission may state whether a consulted person considers that a meeting is necessary or desirable in connection with the matter under consultation, and if so, the reasons why such meeting is necessary or desirable. To be valid, a submission shall be received not later than the date specified in the notice (not to be less than 14 *days*) after the notice referred to in clause 11.9(a) is given.
 - (4) The *consulting party* shall consider all valid submissions within a period of not more than a further 30 *days*. If the *consulting party*, after having considered all valid submissions, concludes that it is desirable or necessary to hold any meetings the *consulting party* shall use its best endeavours to hold such meetings with consulted persons who have requested meetings within a further 14 *days*.
 - (5) Following the conclusion of any such meetings and its consideration of a matter under consultation the *consulting party* shall publish a report, available to all consulted persons, setting out the conclusions and any determinations of the *consulting party*, its reasons for those conclusions and the procedure followed by the *consulting party* in considering the matter and subject to the provisions of clause 11.6, make available to all consulted persons, on request, copies of any material submitted to the *consulting party*.
- (b) The *consulting party* shall not make the decision or determination in relation to which the *Code consultation procedures* apply until the *consulting party* has completed all the procedures set out in this clause.
- (c) Any decision of determination made by the *Commission* as the *consulting party* is a reviewable decision.

CHAPTER 12 TRANSITIONAL PROVISIONS

12.1 GENERAL

12.1.1 Introduction

Transitional provisions are those provisions of the *Code* which shall not apply either in whole or in part to particular *Code Participants* or others for a fixed or indeterminate period. While the time may be indeterminate, as the transitional provision may be contingent upon some event, it is not intended that transitional provisions be permanent. A permanent transitional provision would be effectively a *Code Change* and should be treated as such.

12.1.2 Purpose

- (a) This Chapter shall contain the *transitional provisions* which shall be proposed by *Code Participants* and approved by the *Commission* as provided.
- (b) This Chapter prevails over all other Chapters of the *Code*.
- (c) Transitional provisions are for the purpose of:
 - (1) enabling *Code Participants* to effect an orderly transition to the provisions of the *Code* from currently applying arrangements; and
 - (2) providing specific exemptions from the *Code* for pre-existing arrangements which should continue beyond a specific transition period.
- (d) Any change to this Chapter shall be approved by the *Commission*.
- (e) Unless otherwise stated, clauses 11.3 and 11.4 of the *Code* do not apply to this Chapter.

12.1.3 Objectives

The objectives of the *transitional provisions* are, amongst other things:

- (a) to provide for *distribution network service* pricing for *distribution networks* and *transmission network service* pricing for *transmission networks* to be regulated by the *Commission* to the exclusion of Parts C, D and E of Chapter 5 of the *Code* until such time as the *Commission* determines prices in accordance with the *Act*;
- (b) to enable electricity entities and other bodies participating in the industry to meet obligations under certain power purchase and electricity sale agreements made or committed to prior to the implementation of the *Code*; and
- (c) to provide certain specific transitional provisions from technical standards set out in the *Code* for some *Code Participants*.

12.1.4 Interim arrangements

Until such time as the *Code Participants* are required to comply with the requirements of the provisions of the *Code* which is the subject of a *transitional provision* under this Chapter 12, the *Code Participants* processes and procedures for the *industry* which are in place on the *commencement date* will continue to apply and shall be observed by all *Code Participants*.

12.1.5 Notification of compliance

In the event that a *Code Participant* intends to comply with a particular clause of the *Code* which has been the subject of a *transitional provision* pursuant to this Chapter 12, then the relevant *Code Participant* shall notify all other *Code Participants* that he now intends, or is required, to comply with that particular clause and the interim arrangements no longer apply.

12.2 PROVISIONS RELATING TO SPECIFIC CHAPTERS OF THE CODE

Any *Code Participant* wishing to request exemption for a specific period from the requirements of any provision of the *Code* shall make such request to the *Commission* within one hundred and twenty (120) days from the *commencement date* of this *Code* under the following headings 12.2.1 through to 12.2.9 as appropriate.

12.2.1 Chapter 3 - Network Connection

12.2.2 Chapter 4 - Metering and Retail Supply of Electricity

12.2.3 Chapter 5 - Transmission and Distribution Network Systems

12.2.4 Chapter 6 - Scheduling and Dispatch Process

12.2.5 Chapter 7 - Power System Security

12.2.6 Chapter 8 - Distribution System Operation

12.2.7 Chapter 9 - Generation Capacity Planning and Procurement

12.2.8 Chapter 10 - Ring Fencing

12.2.9 Chapter 11 - Administrative Functions